

Rexroth MHP Synchronous motors for PowerDrive

R911283692
Edition 01

Project Planning Manual



Title POWERDRIVE
 Digital AC- Motors
 MHP

Type of Documentation Project Planning Manual

Document Typecode DOK-MOTOR*-MHP*****-PR01-EN-P

Internal File Reference • Document number: 120-1500-B304-01/EN

Purpose of Documentation This documentation is intended to ...

- Help user familiarize himself with MHP motors
- Help plan the mechanical integration into the facility
- Help plan the electrical connections
- Help order an identify the motor
- Determine motor cables and connectors needed

Record of Revisions

Description	Release Date	Notes
DOK-MOTOR*-MHP*****-PR01-EN-P	02.00	1 st edition

Copyright © 2000 Rexroth Indramat GmbH

Copying this document, giving it to others and the use or communication of the contents thereof without express authority, are forbidden. Offenders are liable for the payment of damages. All rights are reserved in the event of the grant of a patent or the registration of a utility model or design (DIN 34-1).

Validity All rights are reserved with respect to the content of this documentation and the availability of the product.

Published by Rexroth Indramat GmbH
 Bgm.-Dr.-Nebel-Str. 2 • D-97816 Lohr a. Main
 Telephone 09352/40-0 • Tx 689421 • Fax 09352/40-4885
<http://www.rexroth.com/indramat>
 Dept. ECM2 (JW)

Contents

1	Introduction to the MHP AC Motors	1-1
1.1	General Features	1-1
1.2	Versions	1-3
1.3	Motor feedback	1-3
2	Important User Guidelines	2-1
2.1	Proper Use	2-1
	Introduction	2-1
	Pre-requisites	2-1
	Areas of Use and Applications	2-1
	Accessories, Mounted Parts and Peripherals	2-2
	Ambient Conditions	2-2
2.2	Improper Use	2-2
3	Safety Instructions for Electric Servo Drives and Controls	3-1
3.1	Introduction	3-1
3.2	Explanations	3-1
3.3	Hazards by inappropriate use	3-2
3.4	General Information	3-3
3.5	Protection against contact with electrical parts	3-4
3.6	Protection by protective low voltage (PELV) against electrical shock	3-6
3.7	Protection against dangerous movements	3-6
3.8	Protection against magnetic and electromagnetic fields during operations and mounting	3-8
3.9	Protection against contact with hot parts	3-9
3.10	Protection during handling and installation	3-9
3.11	Battery safety	3-10
3.12	Protection against pressurized Systems	3-10
4	Mechanical Integration into the Installation	4-1
4.1	Installation Elevation and Ambient Temperature	4-1
4.2	Protection Category	4-2
	Selecting the protection category	4-4
	Accessories selection list for the sealing air connection	4-5
4.3	Structural shape and Mounting positions	4-6
4.4	Primary coat and Housing coat	4-6
4.5	Maximum vibrations and Shock resistance	4-6
4.6	Driven shafts	4-8
	Available versions	4-8

Shaft load	4-8
4.7 Surface cooling	4-11
4.8 Holding Brake.....	4-11
4.9 Outing direction of the electrical connections	4-13
4.10 Speed/Torque Curves	4-14
5 Electrical Connections	5-1
5.1 An Overview of the Connections.....	5-1
5.2 Power Cable.....	5-2
5.3 Feedback cable	5-10
5.4 Technical data of Power and Feedback cable	5-11
5.5 Individual Parts.....	5-12
Individual Parts for Making INDRAMAT Power Cables	5-12
Parts for Making Power Cables of Third-Party Manufacturers	5-15
Individual Feedback Connection Parts	5-16
6 Coolant Connections	6-1
6.1 Type of Connections	6-1
6.2 How to Connect.....	6-1
7 MHP041	7-1
7.1 Technical data	7-1
7.2 Torque/speed curves	7-4
7.3 Maximum Shaft Load	7-5
7.4 Dimensional Data	7-6
7.5 Available Versions and Type Codes	7-7
8 MHP071	8-1
8.1 Technical data	8-1
8.2 Torque/speed curves	8-4
8.3 Maximum Shaft Load	8-6
8.4 Dimensional data	8-7
8.5 Available Versions and Type Codes	8-8
8.6 Blower Units	8-9
9 MHP090	9-1
9.1 Technical Data	9-1
9.2 Torque/speed curves	9-4
9.3 Maximum Shaft Load	9-5
9.4 Dimensional data	9-6
9.5 Available Versions and type codes	9-7
9.6 Blower Units	9-8
10 MHP093	10-1
10.1 Technical data	10-1
10.2 Torque/speed curves	10-8

10.3	Maximum Shaft Load	10-12
10.4	Dimensional data (standard cooling)	10-13
10.5	Dimensional data (liquid cooling)	10-14
10.6	Available versions and type codes	10-15
10.7	Blower units	10-16
11	MHP095	11-1
11.1	Technical data	11-1
11.2	Torque/speed curves	11-8
11.3	Maximum Shaft Load	11-10
11.4	Dimensional data (standard cooling)	11-11
11.5	Dimensional data (liquid cooling)	11-12
11.6	Available versions and type codes	11-13
11.7	Blower Units	11-14
12	MHP112	12-1
12.1	Technical data	12-1
12.2	Torque/speed curves	12-10
12.3	Maximum Shaft Load	12-14
12.4	Dimensional data	12-15
12.5	Available versions and type codes	12-17
12.6	Blower Units	12-18
13	MHP115	13-1
13.1	Technical data	13-1
13.2	Torque/speed curves	13-7
13.3	Maximum Shaft Load	13-10
13.4	Dimensional data (Standard cooling)	13-11
13.5	Dimensional data (Liquid cooling)	13-12
13.6	Available versions and type codes	13-13
13.7	Blower units	13-14
14	Condition at Delivery	14-1
14.1	General Information	14-1
14.2	Releasing the Metal Bands	14-1
14.3	Shipping Papers	14-1
15	Identifying the Merchandise	15-1
15.1	Delivery slip	15-1
15.2	Barcode Sticker	15-1
15.3	Type Plate	15-2
16	Storage, Transport and Handling	16-1
16.1	Notes on Packaging	16-1
16.2	Storage	16-1
16.3	Transport and Handling	16-2

17 Mounting and Installation	17-1
17.1 General Information on Mounting	17-1
17.2 Mounting Motor	17-1
17.3 Connecting the Motor	17-1
Connecting Standard Cables	17-3
Changing the Output Direction of Power and Feedback Connections	17-4
17.4 Connecting and Mounting the Blower Connector	17-7
17.5 Re-seating the Holding Brake	17-8
18 Service Guidelines	18-1
18.1 Maintenance Work	18-1
18.2 Contacting Customer Service	18-1
18.3 Fault Report	18-2
19 Index	19-1
20 Kundenbetreuungsstellen - Sales & Service Facilities	20-1

1 Introduction to the MHP AC Motors

1.1 General Features

Area of application In conjunction with the POWERDRIVE drive package, digital MHP AC motors construct cost-effective and quick-response drives.

The modular concept of Rexroth Indramat POWERDRIVE drives makes the flexible combination of MHP AC motors possible to form compact drive packages with a standard power supply unit on a Heidenhain TNC410M, TNC426M or TNC430M control.

These servo drives are especially suited for use in:

- Machine tools
- Textile machines
- Printing machines
- Packaging machines
- Robots
- Handling machines

Advantages The following features make MHP motors stand out:

- High operating reliability
- Maintenance-free operation (due to a brushless design and the use service lifespan lubricated bearings)
- They can be used under adverse environmental conditions (due to their completely sealed motor design that meets IP 65 protective standards)
- Overload protection (the result of motor temperature monitoring)
- High power data
- High dynamics (due to favorable torque/inertial mass ratios)
- High overload capabilities (due to favorable heat dissipation from stator windings to the outside wall of the motor housing)
- Peak torque which can be used over a broad speed range (due to electronic commutation)
- Continuous start-stop operations with high repetitive frequencies (due to electronic commutation)
- Easy mounting to the machine (due to a flange that meets DIN 42948 requirements)
- Mounting position as needed
- A direct overhung mounting of pinions and belt discs (this is the result of a bearing designed to accommodate high radial loads)
- Simple cabling (due to standard cables in a variety of lengths and types)

Performance overview MHP motors with the following continuous torques at standstill and nominal speeds are available:

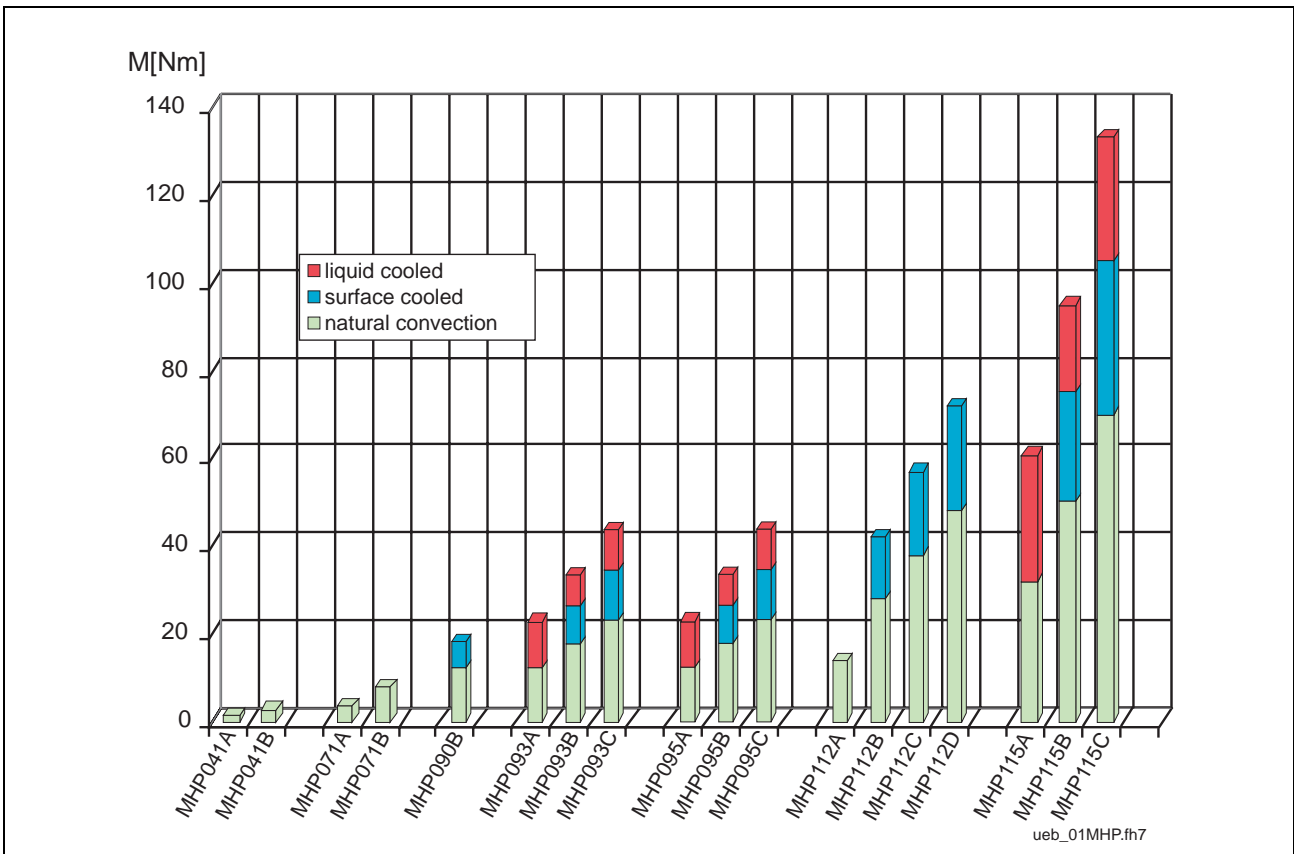

Fig. 1-1: Continuous torques at standstill of MHP motors

Construction and Parts MHP motors are permanent-magnet excited motors with electronic commutation. Special magnetic materials permit a design with lower inertial mass. The following illustrates the basic construction principle of MHP motors.

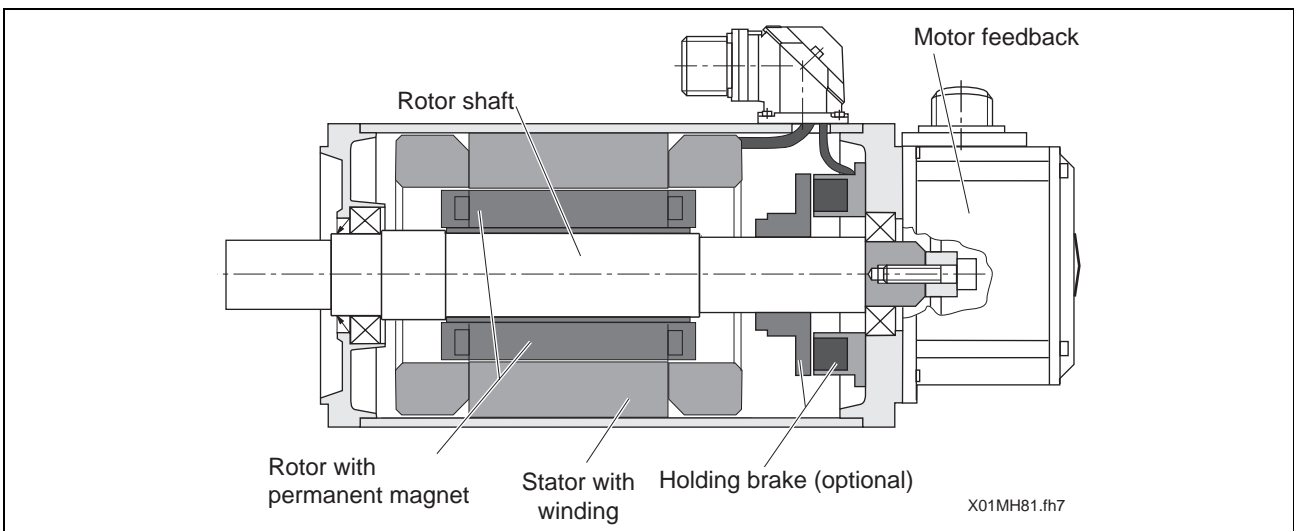

Fig. 1-2: Construction of MHP motors

1.2 Versions

MHP motors come in different versions:

Holding brake Option. For a safe holding of the axis if no power is being supplied to the motor. See relevant section 4.8 for details.

Driven shaft Available as either

- a plain shaft (standard) or
- shaft with keyway (this is optional).

For more details on the subject, see the relevant section 4.6.

Cooling mode If a cooling mode other than the standard one, i.e., “natural convection” is to be used, then alternate cooling methods are available with the following motor types:

- surface cooling (MHP071, MHP090, MHP093, MHP112 and MHP115)
- liquid cooled (MHP093 and MHP115)

For more details on the subject, see the relevant sections 4 and 6.

1.3 Motor feedback

To control the speed of the motor or to position the motor, the Heidenhain control must know what the current motor position is.

The integrated motor feedback generates the relevant signals for the control.

Technical data of the motor feedback

Designation	Incremental encoder feedback FSP01
Measuring principle	optical
Resolution	2048 Information/ revolution
Signal form	Sine 1V _{ss} with Z1 track

Fig. 1-3: Technical data of the motor feedback

2 Important User Guidelines

2.1 Proper Use

Introduction

Digital MHP AC motors from Rexroth Indramat represent state-of-the-art development and manufacturing. All motors are checked prior to delivery for operating reliability and safety.

If AC motors are not used as intended, then dangerous situations could result that could cause property damage or injury to personnel. To avoid this, the following sections should be read and understood prior to mounting or starting AC motors.

Note: For damage resulting from improper use of the motors, Rexroth Indramat, as manufacturer, assumes no responsibility, liability or payment of damages. All risks with improper use of AC motors are the sole responsibility of the user.

Pre-requisites

Before MHP AC motors made by Rexroth Indramat are put into use, the following pre-requisites must be met to ensure their proper use:

- Any and every person who handles the motors in anyway either during mounting, start-ups or maintenance must have the appropriate training. This person must also be familiar with safety guidelines and what proper use means. He/she can do so by reading and understanding the relevant sections of this document.
- Any damaged or faulty motors should not be mounted or started up.
- The power supply unit must be functional, must be the right one to use with that motor and must be connected to the motor in the way which is specified in the documentation.

Areas of Use and Applications

MHP AC motors from Rexroth Indramat are intended for use with POWERDRIVE drive controllers and a continuous path control made by Heidenhain which realizes application-specific axis movements.

Typical MHP motor application areas are

- machine tools
- textile machines
- printing machines
- packaging machines
- robots
- handling machines
- gantry axes
- machining centers

Accessories, Mounted Parts and Peripherals

The motors may only be operated with the accessories and parts specified in this document. Especially blower units and plug-in connections must be original Rexroth Indramat parts or facsimiles.

Ambient Conditions

Motors may only be operated under the conditions described in section 4 for mounting onto, integrating and assembling, in the positions dictated and under the ambient conditions described (ambient temperatures, protection category, vibrations, EMC and so on).

2.2 Improper Use

Operating the motors outside of the specified applications or under conditions other than those outlined in the documentation or using the equipment with other than specified technical data is defined as "improper use".

MHP AC motors may not be operated in the areas listed below without the express official permission from Rexroth Indramat:

- Person or freight elevators including vehicles for transport of persons
- Airplanes, ship/boat technology
- Medical technology
- Crane construction
- Refining facilities
- Burning and furnace facilities
- Weapon technologies
- Nuclear applications
- Mining and areas endangered by explosions
- Safety-relevant applications of all kinds and control of protective devices
- Foodstuff processing

Note: This list is in no way complete and can be expanded in some of the above listed areas.

Applications of this kind are not allowed without the use of safety measures that have been specifically adapted to each individual case.

3 Safety Instructions for Electric Servo Drives and Controls

3.1 Introduction

Read these instructions before the equipment is used and eliminate the risk of personal injury or property damage. Follow these safety instructions at all times.

Do not attempt to install, use or service this equipment without first reading all documentation provided with the product. Read and understand these safety instructions and all user documentation of the equipment prior to working with the equipment at any time. If you do not have the user documentation for your equipment contact your local Rexroth Indramat representative to send this documentation immediately to the person or persons responsible for the safe operation of this equipment.

If the product is resold, rented or transferred or passed on to others, then these safety instructions must be delivered with the product.



Inappropriate use of this equipment, failure to follow the safety instructions in this document or tampering with the product, including disabling of safety devices, may result in product damage, personal injury, severe electrical shock or death!

3.2 Explanations

The safety warnings in this documentation describe individual degrees of hazard seriousness in compliance with ANSI:

Warning symbol with signal word	Degree of hazard seriousness
	The degree of hazard seriousness describes the consequences resulting from non-compliance with the safety guidelines. Bodily harm or product damage will occur.
	Death or severe bodily harm may occur.
	Death or severe bodily harm may occur.

Fig. 3-1: Classes of danger with ANSI

3.3 Hazards by inappropriate use



DANGER

**High voltage and high discharge current!
Danger to life, risk of severe electrical shock
and risk of injury!**



DANGER

**Dangerous movements! Danger to life and risk
of injury or equipment damage by unintentional
motor movements!**



WARNING

**High electrical voltage due to wrong
connections! Danger to life, severe electrical
shock and severe bodily injury!**



WARNING

**Health hazard for persons with heart
pacemakers, metal implants and hearing aids in
proximity to electrical equipment!**



CAUTION

**Surface of machine housing could be extremely
hot! Danger of injury! Danger of burns!**



CAUTION

**Risk of injury due to inappropriate handling!
Bodily injury caused by crushing, shearing,
cutting and mechanical shock or improper
handling of pressurized systems!**



CAUTION

**Risk of injury due to inappropriate handling of
batteries!**

3.4 General Information

- Rexroth Indramat GmbH is not liable for damages resulting from failure to observe the warnings given in these documentation.
- Order operating, maintenance and safety instructions in your language before starting up the machine. If you find that due to a translation error you can not completely understand the documentation for your product, please ask your supplier to clarify.
- Proper and correct transport, storage, assembly and installation as well as care in operation and maintenance are prerequisites for optimal and safe operation of this equipment.
- Trained and qualified personnel in electrical equipment:
Only trained and qualified personnel may work on this equipment or within its proximity. Personnel are qualified if they have sufficient knowledge of the assembly, installation and operation of the product as well as an understanding of all warnings and precautionary measures noted in these instructions.
Furthermore, they should be trained, instructed and qualified to switch electrical circuits and equipment on and off, to ground them and to mark them according to the requirements of safe work practices and common sense. They must have adequate safety equipment and be trained in first aid.
- Only use spare parts and accessories approved by the manufacturer.
- Follow all safety regulations and requirements for the specific application as practiced in the country of use.
- The equipment is designed for installation on commercial machinery.
European countries: see directive 89/392/EEC (machine guideline).
- The ambient conditions given in the product documentation must be observed.
- Use only safety features that are clearly and explicitly approved in the Project Planning manual.
For example, the following areas of use are not allowed: Construction cranes, Elevators used for people or freight, Devices and vehicles to transport people, Medical applications, Refinery plants, the transport of hazardous goods, Radioactive or nuclear applications, Applications sensitive to high frequency, mining, food processing, Control of protection equipment (also in a machine).
- Start-up is only permitted once it is sure that the machine, in which the product is installed, complies with the requirements of national safety regulations and safety specifications of the application.
- Operation is only permitted if the national EMC regulations for the application are met.
The instructions for installation in accordance with EMC requirements can be found in the INDRAMAT document "EMC in Drive and Control Systems".
The machine builder is responsible for compliance with the limiting values as prescribed in the national regulations and specific EMC regulations for the application.
European countries: see Directive 89/336/EEC (EMC Guideline).
U.S.A.: See National Electrical Codes (NEC), National Electrical Manufacturers Association (NEMA), and local building codes. The user of this equipment must consult the above noted items at all times.
- Technical data, connections and operational conditions are specified in the product documentation and must be followed at all times.

3.5 Protection against contact with electrical parts

Note: This section refers to equipment with voltages above 50 Volts.

Making contact with parts conducting voltages above 50 Volts could be dangerous to personnel and cause an electrical shock. When operating electrical equipment, it is unavoidable that some parts of the unit conduct dangerous voltages.



DANGER

High electrical voltage! Danger to life, severe electrical shock and severe bodily injury!

- ⇒ Only those trained and qualified to work with or on electrical equipment are permitted to operate, maintain or repair this equipment.
- ⇒ Follow general construction and safety regulations when working on electrical installations.
- ⇒ Before switching on power the ground wire must be permanently connected to all electrical units according to the connection diagram.
- ⇒ Do not operate electrical equipment at any time if the ground wire is not permanently connected, even for brief measurements or tests.
- ⇒ Before working with electrical parts with voltage potentials higher than 50 V, the equipment must be disconnected from the mains voltage or power supply.
- ⇒ The following should be observed with electrical drives, power supplies, and filter components:
Wait five (5) minutes after switching off power to allow capacitors to discharge before beginning work. Measure the voltage on the capacitors before beginning work to make sure that the equipment is safe to touch.
- ⇒ Never touch the electrical connection points of a component while power is turned on.
- ⇒ Install the covers and guards provided with the equipment properly before switching the equipment on. Prevent contact with live parts at any time.
- ⇒ A residual-current-operated protective device (r.c.d.) must not be used on an electric drive! Indirect contact must be prevented by other means, for example, by an overcurrent protective device.
- ⇒ Equipment that is built into machines must be secured against direct contact. Use appropriate housings, for example a control cabinet.

European countries: according to EN 50178/1998, section 5.3.2.3.

U.S.A: See National Electrical Codes (NEC), National Electrical Manufacturers Association (NEMA) and local building codes. The user of this equipment must observe the above noted instructions at all times.

To be observed with electrical drives, power supplies, and filter components:



DANGER

**High electrical voltage! High leakage current!
Danger to life, danger of injury and bodily harm
from electrical shock!**

- ⇒ Before switching on power for electrical units, all housings and motors must be permanently grounded according to the connection diagram. This applies even for brief tests.
- ⇒ Leakage current exceeds 3.5 mA. Therefore the electrical equipment and units must always be firmly connected to the supply network.
- ⇒ Use a copper conductor with at least 10 mm² cross section over its entire course for this protective connection!
- ⇒ Prior to startups, even for brief tests, always connect the protective conductor or connect with ground wire. High voltage levels can occur on the housing that could lead to severe electrical shock and personal injury.

European countries: EN 50178/1998, section 5.3.2.1.

USA: See National Electrical Codes (NEC), National Electrical Manufacturers Association (NEMA), and local building codes. The user of this equipment must maintain the above noted instructions at all times.

3.6 Protection by protective low voltage (PELV) against electrical shock

All connections and terminals with voltages between 5 and 50 Volts on INDRAMAT products are protective low voltages designed in accordance with the following standards on contact safety:

- International: IEC 364-4-411.1.5
- EU countries: see EN 50178/1998, section 5.2.8.1.



WARNING

High electrical voltage due to wrong connections! Danger to life, severe electrical shock and severe bodily injury!

- ⇒ Only equipment, electrical components and cables of the protective low voltage type (PELV = Protective Extra Low Voltage) may be connected to all terminals and clamps with 0 to 50 Volts.
- ⇒ Only safely isolated voltages and electrical circuits may be connected. Safe isolation is achieved, for example, with an isolating transformer, an opto-electronic coupler or when battery-operated.

3.7 Protection against dangerous movements

Dangerous movements can be caused by faulty control or the connected motors. These causes are be various such as:

- unclean or wrong wiring of cable connections
- inappropriate or wrong operation of equipment
- malfunction of sensors, encoders and monitoring circuits
- defective components
- software errors

Dangerous movements can occur immediately after equipment is switched on or even after an unspecified time of trouble-free operation.

The monitors in the drive components make faulty operation almost impossible. Regarding personnel safety, especially the danger of bodily harm and property damage, this alone should not be relied upon to ensure complete safety. Until the built-in monitors become active and effective, it must be assumed in any case that some faulty drive movements will occur. The extent of these faulty drive movements depends upon the type of control and the state of operation.

**DANGER**

Dangerous movements! Danger to life and risk of injury or equipment damage!

⇒ Personnel protection must be secured for the above listed reason by means of superordinate monitors or measures.

These are instituted in accordance with the specific situation of the facility and a danger and fault analysis conducted by the manufacturer of the facility. All the safety regulations that apply to this facility are included therein. By switching off, circumventing or if safety devices have simply not been activated, then random machine movements or other types of faults can occur.

Avoiding accidents, injury or property damage:

⇒ Keep free and clear of the machine's range of motion and moving parts. Prevent people from accidentally entering the machine's range of movement:

- use protective fences
- use protective railings
- install protective coverings
- install light curtains or light barriers

⇒ Fences must be strong enough to withstand maximum possible momentum.

⇒ Mount the emergency stop switch (E-stop) in the immediate reach of the operator. Verify that the emergency stop works before startup. Don't operate the machine if the emergency stop is not working.

⇒ Isolate the drive power connection by means of an emergency stop circuit or use a start-inhibit system to prevent unintentional start-up.

⇒ Make sure that the drives are brought to standstill before accessing or entering the danger zone.

⇒ Secure vertical axes against falling or slipping after switching off the motor power by, for example:

- Mechanically securing the vertical axes
- Adding an external brake / clamping mechanism
- Balancing and thus compensating for the vertical axes mass and the gravitational force

The standard equipment motor brake or an external brake controlled directly by the servo drive are not sufficient to guarantee the safety of personnel!

- ⇒ Disconnect electrical power to the equipment using a master switch and secure the switch against reconnection for:
 - maintenance and repair work
 - cleaning of equipment
 - long periods of discontinued equipment use
 - ⇒ Avoid operating high-frequency, remote control and radio equipment near electronics circuits and supply leads. If use of such equipment cannot be avoided, verify the system and the plant for possible malfunctions at all possible positions of normal use before the first start-up. If necessary, perform a special electromagnetic compatibility (EMC) test on the plant.
-

3.8 Protection against magnetic and electromagnetic fields during operations and mounting

Magnetic and electromagnetic fields generated by current-carrying conductors and permanent magnets in motors represent a serious health hazard to persons with heart pacemakers, metal implants and hearing aids.



WARNING

- Health hazard for persons with heart pacemakers, metal implants and hearing aids in proximity to electrical equipment!**
- ⇒ Persons with pacemakers, metal implants and hearing aids are not permitted to enter following areas:
 - Areas in which electrical equipment and parts are mounted, being operated or started up.
 - Areas in which parts of motors with permanent magnets are being stored, operated, repaired or mounted.
 - ⇒ If it is necessary for a person with a pacemaker to enter such an area, then a physician must be consulted prior to doing so. Pacemaker, that are already implanted or will be implanted in the future, have a considerable deviation in their resistance to interference. Due to the unpredictable behavior there are no rules with general validity.
 - ⇒ Persons with hearing aids, metal implants or metal pieces must consult a doctor before they enter the areas described above. Otherwise health hazards will occur.
-

3.9 Protection against contact with hot parts



CAUTION

**Housing surfaces could be extremely hot!
Danger of injury! Danger of burns!**

- ⇒ Do not touch surfaces near the source of heat! Danger of burns!
- ⇒ Wait ten (10) minutes before you access any hot unit. Allow the unit to cool down.
- ⇒ Do not touch hot parts of the equipment, such as housings, heatsinks or resistors. Danger of burns!

3.10 Protection during handling and installation

Under certain conditions inappropriate handling and installation of parts and components may cause injuries.



CAUTION

**Risk of injury through incorrect handling!
Bodily harm caused by crushing, shearing,
cutting and mechanical shock!**

- ⇒ Observe general instructions and safety regulations during handling installation.
- ⇒ Use only appropriate lifting or moving equipment.
- ⇒ Take precautions to avoid pinching and crushing.
- ⇒ Use only appropriate tools. If specified by the product documentation, special tools must be used.
- ⇒ Use lifting devices and tools correctly and safely.
- ⇒ Wear appropriate protective clothing, e.g. safety glasses, safety shoes and safety gloves.
- ⇒ Never stay under suspended loads.
- ⇒ Clean up liquids from the floor immediately to prevent personnel from slipping.

3.11 Battery safety

Batteries contain reactive chemicals in a solid housing. Inappropriate handling may result in injuries or equipment damage.



Risk of injury through incorrect handling!

- ⇒ Do not attempt to reactivate discharged batteries by heating or other methods (danger of explosion and corrosion).
- ⇒ Never charge batteries (danger from leakage and explosion).
- ⇒ Never throw batteries into a fire.
- ⇒ Do not dismantle batteries.
- ⇒ Handle with care. Incorrect extraction or installation of a battery can damage equipment.

Note: Environmental protection and disposal! The batteries contained in the product should be considered as hazardous material for land, air and sea transport in the sense of the legal requirements (danger of explosion). Dispose batteries separately from other refuse. Observe the legal requirements given in the country of installation.

3.12 Protection against pressurized Systems

Certain Motors (ADS, ADM, 1MB etc.) and drives, corresponding to the information in the Project Planning manual, must be provided with and remain under a forced load such as compressed air, hydraulic oil, cooling fluid or coolant. In these cases, improper handling of the supply of the pressurized systems or connections of the fluid or air under pressure can lead to injuries or accidents.



Danger of injury when pressurized systems are handled by untrained personnel!

- ⇒ Do not attempt to disassemble, to open or to cut a pressurized system.
- ⇒ Observe the operation restrictions of the respective manufacturer.
- ⇒ Before the disassembly of pressurized systems, lower pressure and drain off the fluid or gas.
- ⇒ Use suitable protective clothing (for example protective eyewear, safety shoes and gloves)
- ⇒ Remove any fluid that has leaked out onto the floor immediately.

Note: Environmental protection and disposal! The fluids used in the operation of the pressurized system equipment is not environmentally compatible. Fluid that is damaging to the environment must be disposed of separate from normal waste. Observe the national specifications of the country of installation.

4 Mechanical Integration into the Installation

4.1 Installation Elevation and Ambient Temperature

- Nominal data** The power data of the motor as specified apply to:
- ambient temperatures of 0° to +40° C
 - Installation elevation 0 to 1000 meters above level

Exceeding nominal data If the motors are used above this range, then allow for the “Load factors”. This means that the power data are reduced.

⇒ In such cases as these, check whether the power data suffice for your application. To determine load factors use Fig. 4-1. The use of temperature and installation elevations higher than those specified in basically not permitted!

Note: Motor damage and forfeiture of guarantee!

- Motors operated outside of the specified range could be damaged as a result. Doing so also means loss of the guarantee. Therefore, please comply with all the following instructions!
-

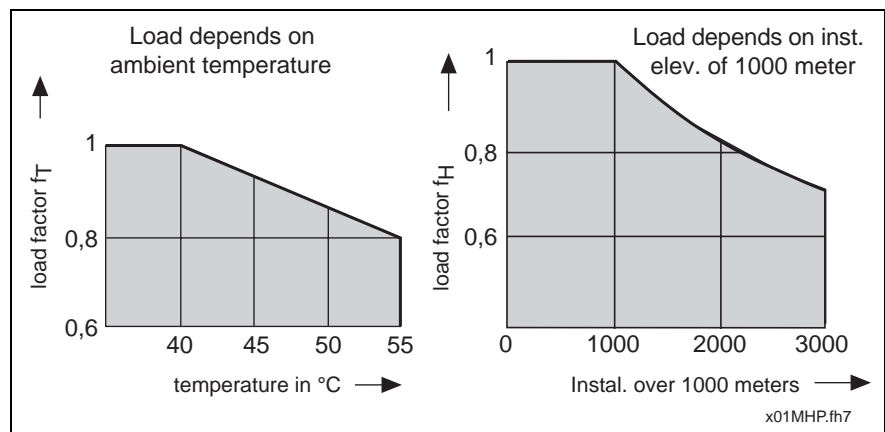

Fig. 4-1: Load factor as dependent on ambient temperature and installation elevation

In the event that **either** the ambient temperature **or** the installation elevation exceed the nominal data range:

- ⇒ Multiply the torque data specified in the selection data by the load factor which has been determined.
- ⇒ Make sure that the application does not exceed the reduced torque data.

If **both** the ambient temperature **and** installation elevation exceed nominal data, then:

- ⇒ Multiple the determined load factors f_T and f_H .
- ⇒ Multiply the multiplicand by the motor's torque data as specified in the selection data.

Make sure that your application does not exceed the reduced torque data.

4.2 Protection Category

The design of MHP motors meets the following specs of protection category as outlined in DIN VDE 0470 Sec. 1, edition dated 11/1992 (EN 60 529):

Area of motor	Protection category	Comment
motor housing, driven shaft, power, feedback connections (only if correctly mounted)	approx. IP67	version with option sealing air connection
motor housing, driven shaft, power, feedback connections (only if correctly mounted)	IP 65	standard design
blower motor	IP 44	standard design
surface cooling (blower grid) and blower connection	IP 24	standard design

Fig. 4-2: Protection category areas of motors

The protection category is identified with the letters IP (International Protection) and two digits that correspond to the degree of protection.

The **first digit** describes the degree of protection against contact and penetration by foreign objects. The **second digit** describes the degree of protection against water.

First digit	Degree of protection
6	Protection against penetration by dust (dust-proof); complete contact penetration
4	Protection against the penetration of solid foreign objects with a diameter exceeding 1mm
2	Protection against the penetration of solid foreign objects with a diameter exceeding 12 mm ⇒ Keeps fingers and similar objects away!
Second digit	Degree of protection
7	Protection against damaging effects if temporarily submerged in water
5	Protection against a jet of water from a nozzle pointed at the housing and coming from all directions (jet of water)
4	Protection against water being sprayed from all directions at the housing (spray water)

Fig. 4-3: IP protection categories

Note: The tests for determining the second digit use fresh water. If cleaning procedures use high pressure and/or cleaning solutions, coolants, lubricants or oils, then it may be necessary to use a higher protection category.

Option sealing air connection

Sealing air connections are available for some motor types. These are easily mounted to the motor by simply exchanging the motor flanged socket lid. By generating a specific overpressure within the interior of the motor, it is possible to reliably prevent penetration by, e.g., oils or aggressive coolants.

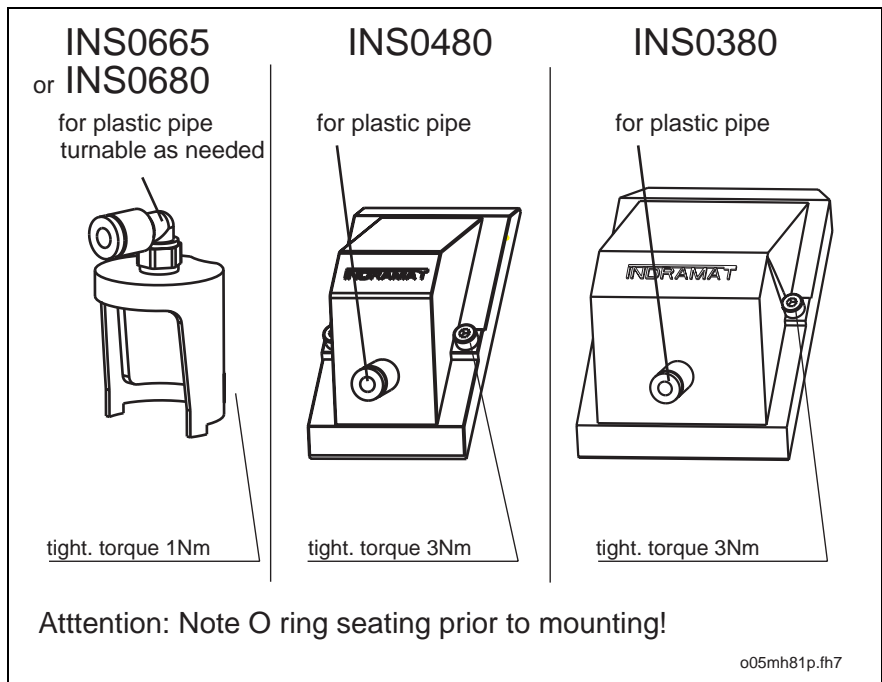

Fig. 4-4: Motor flange socket lid with sealing air connection

Note: When mounting the motor flange socket lid with a sealing air connection, make sure that the O rings are properly seated. Only if mounting is absolutely correct can the needed protection category be guaranteed.

Compressed air data:

Pressure	0.1 to 0.2 bar, max. 0.3 bar
Air	dust and oil free
Relative humidity	20 to 30%

Plastic pipe recommended by supplier: Rexroth Mecmann Pneumatik GmbH
 Barweg 13
 30453 Hannover
 Tel: +49 (0)511 21 36 0
 Fax: +49 (0)511 21 36 269

Plastic pipe type **PA 4x 0.75**

Dimension [mm]	Length [m]	Color	Order number
4 x 0.75	25	blue	281 520 402 0
	50	blue	281 520 405 0

Fig. 4-5: Plastic pipe

Accessory kit designations The available motor flange socket lid with sealing air connection are listed in the table below.

Motor flange socket (Type)	Accessories designation sealing air connection
INS0480 (Power connection)	SUP-M01-MHD
INS0380 (Power connection)	SUP-M02-MHD
INS0665 (Feedback connector) or INS0680 (Power connection)	SUP-M03-MHD

Fig. 4-6: Accessories for sealing air connection

**WARNING****Danger to personnel or damage to property !**

The improper connection of power and/or feedback connectors can endanger personnel or damage the motor !

- ⇒ Make sure that the power and feedback connections are correctly mounted.
- ⇒ Use the motors only in that environment that can ensure the specified protection category.

Selecting the protection category

The protection category must be selecting allowing for mounting position within the application range.

To select the needed protection category, use the following table.

Effect	Medium	Recommended protection category
dry	air	IP65
humid	water; general coolant oil (approx. 5%)	IP65
	oils, bio-oils; aggressive coolant	IP65 with sealing air (approx. IP67)
gush of water	water; general coolant oil (approx. 5%)	IP65 with sealing air (approx. IP67)
	oils, bio-oils; aggressive coolant	IP65 with sealing air (approx. IP67)

Fig. 4-7: Selecting the protection category

Accessories selection list for the sealing air connection

The following list offers an overview of the motors for which the option sealing air connection is available.

Overview accessories: sealing air connection for MHP motors				
Motor type	INS0613/-0613	INS0480	INS0380	Accessories for sealing air connection
MHP 041 A-144	X			SUP-M03-MHD
MHP 041 B-144	X			SUP-M03-MHD
MHP 071 A-061	X			SUP-M03-MHD
MHP 071 B-035	X			SUP-M03-MHD
MHP 071 B-061	X			SUP-M03-MHD
MHP 090 B-035	X			SUP-M03-MHD
MHP 090 B-047	X			SUP-M03-MHD
MHP 090 B-058	X			SUP-M03-MHD
MHP 093 A-035		X		SUP-M01-MHD
MHP 093 A-058		X		SUP-M01-MHD
MHP 093 B-035		X		SUP-M01-MHD
MHP 093 B-058		X		SUP-M01-MHD
MHP 093 C-035		X		SUP-M01-MHD
MHP 093 C-058		X		SUP-M01-MHD
MHP 095 A-024		X		SUP-M01-MHD
MHP 095 A-035		X		SUP-M01-MHD
MHP 095 A-058		X		SUP-M01-MHD
MHP 095 B-035		X		SUP-M01-MHD
MHP 095 B-058		X		SUP-M01-MHD
MHP 095 C-035		X		SUP-M01-MHD
MHP 095 C-058		X		SUP-M01-MHD
MHP 112 A-024		X		SUP-M01-MHD
MHP 112 A-058		X		SUP-M01-MHD
MHP 112 B-024		X		SUP-M01-MHD
MHP 112 B-048		X		SUP-M01-MHD
MHP 112 B-058		X		SUP-M01-MHD
MHP 112 C-024		X		SUP-M01-MHD
MHP 112 C-058			X	SUP-M02-MHD
MHP 112 D-027		X		SUP-M01-MHD
MHP 115 A-024			X	SUP-M02-MHD
MHP 115 A-058			X	SUP-M02-MHD
MHP 115 B-024			X	SUP-M02-MHD
MHP 115 B-058			X	SUP-M02-MHD
MHP 115 C-024			X	SUP-M02-MHD
MHP 115 C-058			X	SUP-M02-MHD

Fig. 4-8: Sealing air connection accessories for MHP motors

4.3 Structural shape and Mounting positions

Structural shape: B05 for flange mounting

Mounting positions: any

Per DIN IEC 34-7, edition dated 12/1992, the following mounting positions are permitted:

- IM B5 (horizontal)
- IM V1 (vertical, driven shaft downward)
- IM V3 (vertical, driven shaft upward)

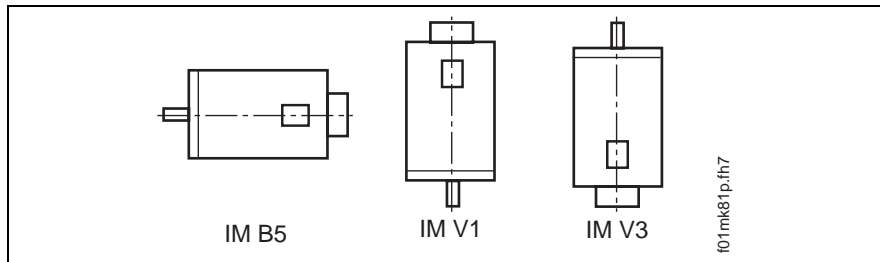

Fig. 4-9: Mounting positions



CAUTION

Penetration by liquids !

Liquids can penetrate motors mounted as per IM V3. These liquids collect over extended periods at the driven shaft, then gradually leak in and cause damage.

⇒ Therefore, make sure that no liquids can collect at the driven shaft.

4.4 Primary coat and Housing coat

State at delivery: Primary coat black (RAL 9005)

Resistance: to weathering, yellowing, chalking, diluted acids and diluted caustic solutions.

An additional coat of paint on the housing is possible (maximum thickness of coat 40 µm).

4.5 Maximum vibrations and Shock resistance

MHP motors are only suited for such demands as occur, for example, when pressing, punching or press feeding if they have been mounted in a shock-damped or shock-decoupled manner. The construction in this case depends on the way the motor is used and should be tested prior to taking up operation.

Note: Motor damage and forfeiture of guarantee!

- Motors not used in the specified manner within the specified range could be damaged. The guarantee is also forfeited. Therefore, please comply with all instructions!

Per IEC 721-3-3, edition dated 1987 or EN 60721-3-3, edition dated 06/1994 MHP motors may be operated in a stationary and weather protected manner under the following conditions:

- Motor horizontal axis: per class 3M1
- Motor vertical axis: per class 3M6

⇒ Make sure that the limit data as specified in Fig. 4-10 and Fig. 4-11 are not exceeded for storage, transport and operation.

Variable	Unit	Maximum value of horizontal axis	Maximum value of vertical axis
Amplitude of excursion with 2 to 9 Hz	mm	0.3	7.0
Amplitude of acceleration with 9 to 200 Hz	m/s ²	1	20

Fig. 4-10: Limit data for sinusoidal oscillations

Variable	Unit	Maximum value of horizontal axis	Maximum value of vertical axis
Total shock/response spectrum (per IEC721-1, ed. 1990; table1, section 6)		type L	type II
Ref. accel (in IEC 721 peak accel specified)	m/s ²	40	250
Duration	ms	22	6

Fig. 4-11: Limit data for shock loads

Note: Motors with mounted blowers for applications with shock loads such as is the case with

- stamping
- pressing or
- gantry axes

not suited. In those cases, use motors without surface cooling and greater torques.

4.6 Driven shafts

Available versions

Plain driven shaft For a backlash free and form-fitting transmission of the torque.
 ⇒ Use chucking sets or other chucking components to couple to pinions, belt discs or similar drive components.

Driven shaft with keyway (Per DIN 6885, sheet 1; edition dated 08/1968). For the form-fitting transmission of torque with low demands made of the shaft/hub connection.

Note: Shaft could be damaged!

- During powerful reverse operations, the seat of the key should swing out. Ever-increasing deformations in this area can then cause the shaft to break. It is therefore preferable to use a driven shaft.
-

Shaft load

Radial and axis forces effect the driven shaft:

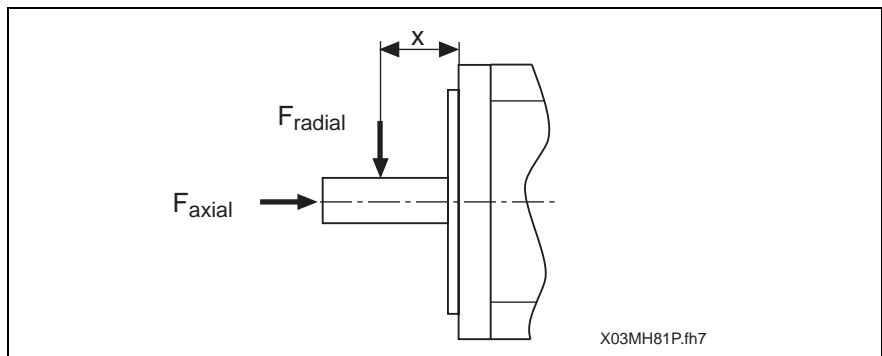

Fig. 4-12: Shaft load forces

Note: Motor damage and forfeiture of guarantee!

- Excessive shaft loads can damage the motor and shorten bearing service life. The guarantee is also forfeited. Therefore, please comply with the following instructions!
-

Maximum allowed radial force
 $F_{\text{radial_max}}$

Maximum allowed radial force $F_{\text{radial_max}}$ depends on shaft break load. It is determined by distance x of the point of application of force and the type of driven shaft used (plain shaft or shaft with keyway).

The chapter 7 to 13 contains the section "Maximum shaft load".

⇒ Using the curve shown there determine the maximum allowed radial force $F_{\text{radial_max}}$ for your application.

⇒ Make sure that the radial force is not exceeded in operation.

Allowed radial force F_{radial}

The allowed radial load F_{radial} depends on the bearing service life wanted. It is based on the arithmetically determined speed of the motor n_{mittel} and distance x of the point of application of force (see Fig. 4-13).

The chapter 7 to 13 contains the section "Maximum shaft load".

⇒ Using the curve shown there determine the allowed radial load F_{radial} for your application.

⇒ Make sure that the determined radial load is not exceeded during operation.

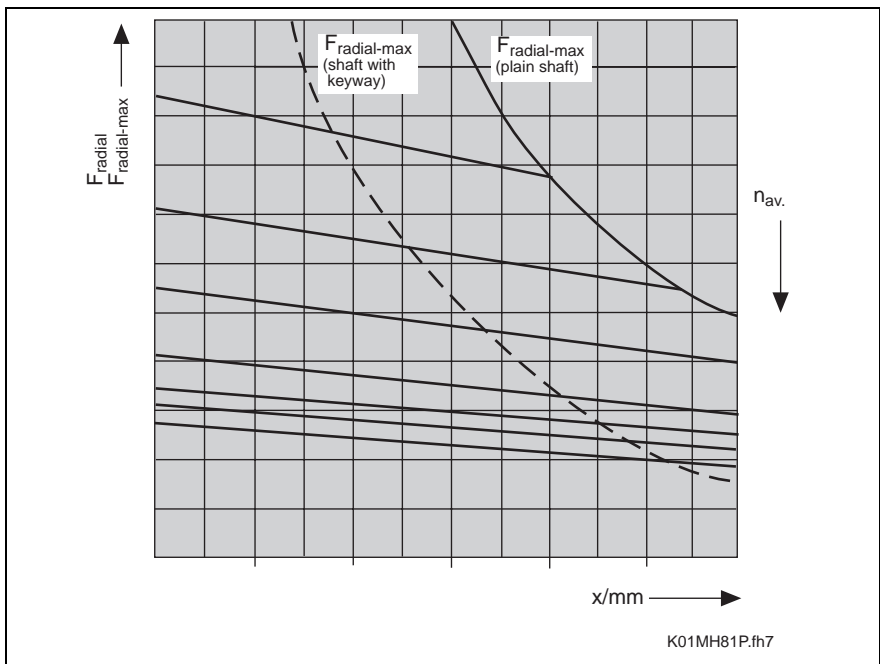

Fig. 4-13: Example diagram for understanding maximum allowed or allowed radial loads

Allowed Axial force F_{axial}

It is proportional to the allowed radial load F_{radial} .

The proportionality factor is also listed in chapter 7 through 13, in section "Maximum shaft load".

⇒ Using the formula shown there determine the maximum allowed axial force F_{axial} for your application.

⇒ Make sure that the determined axial force is not exceeded in operation. Note the following on this!

Note: Thermal effects can cause the flanged end of the driven shaft to shift up to 06. mm away from the motor housing. If helical gears or bevel wheel pinions that are directly mounted to the driven shaft are used, then this will lead to changes in the length

- and to a change in the position of the axis if the drive pinions are not axially fixed to the machine
- or to a thermally-dependent component of the axial force, if the drive pinions are axially mounted to the machine. The danger here is that the maximum allowed axial force will be exceeded or the play within the gears will rise to unacceptable levels.

It is advisable in such cases to use drive components with their own bearings connected to the motor shaft via axially compensating couplings.

Bearing service life L_{10h}

If both allowed radial and axial forces are not exceeded, then it applies to the nominal bearing service life:

$L_{10h} = 30,000$ operating hours (computed per ISO 281, edition dated 12/1990).

Bearing service life otherwise is reduced:

$$L_{10h} = \left(\frac{F_{radial}}{F_{radial_ist}} \right)^3 \cdot 30000$$

L_{10h} : Bearing service life (per ISO 281, edition dated 12/1990)
 F_{radial} : determined allowed radial load in N
 F_{radial_ist} : actually effective radial load in N

Fig. 4-14: Computing bearing service life if exceeding allowed radial load F_{radial}

Note: The actually effective radial load F_{radial_ist} may never exceed maximum allowed radial load F_{radial_max} .

Mounting drive components

Note: When mounting drive components to the driven shaft a redundant bearing must absolutely be avoided. The inevitably existing tolerances generate additional forces effecting the bearings of the motor shaft and thus to a clearly reduced bearing service life. If a redundant bearing is unavoidable, then please first consult with Rexroth Indramat!

4.7 Surface cooling

For extreme loads such as occur with continuous start/start operations with high repetitive frequencies, radial surface cooling can be mounted to MHP071, MHP090, MHP093, MHP112 and MHP115 motors.

Blower motors operating with supply voltages of 1xAC230 V and 1xAC115 V are available.

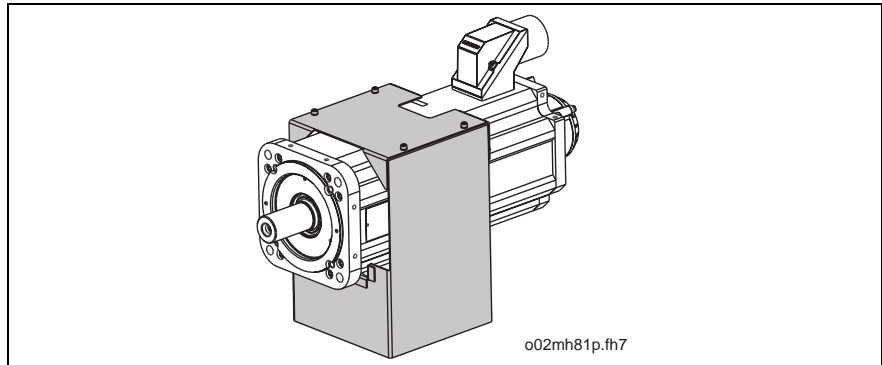

Fig. 4-15: Examples of an MHP motor with radial surface cooling

Radial surface cooling is listed at the time of order as a sub item of the motor „mounted to the motor“. For detailed information on how to order, see sections 8 to 4.9.

Note: Motors with mounted blower units are **not suited** for applications with shock loads as occurring during

- stamping
- pressing or
- in gantry axes.

In such cases, use motors without surface cooling and higher torques.

4.8 Holding Brake

Option. For holding the servo axis when the machine is without power.

The holding brake works with the principle of "electrically releasing". When there is no power, a magnetic force effects the anchor disc of the brake. This closes the brake and holds the axis.

With the application of 24 VDC the continuous magnetic field is replaced with the electrically generated magnetic field and the brake opens.

The holding brake is controlled by the controller. This ensures the correct on/off sequence in all operating states.

**DANGER****Dropping axis!**

Personnel endangered by pinching or cutting off of body parts.

⇒ The holding brake alone does not ensure personnel safety. Safety must be ensured by more extensive structural measures such as protective fences or grids or equipping the installation with a second brake.

Note: Premature wear of holding brake possible !

- The holding brake wears down after about 20,000 revolutions of the motor in a closed state. That is why the holding brake should not be used as a brake that brings an axis in motion to a standstill. This is only permitted in an emergency stop situation.

Check holding torque before starting up the machine.

Note: If motors have been stored for extended periods, then the transmittable torque of the holding brake must be checked before the motor is used. If the torque as specified in the data sheets is not achieved, then it is necessary to adjust the motor before use.

⇒ Please note the information in section „17.5, Re-seating the Holding Brake“.

4.9 Outing direction of the electrical connections

Power connection As per Fig. 4-16 the outgoing direction of the electrical power connection can be set as needed.

Connection	Possible output directions
Plug-in connector with turnable housing (MHP041, MHP071 and MHP090)	 <p>Areas in which the output directions may overlap</p> <p>swivel range (270°) feedback conn.</p> <p>swivel range (270°) power conn.</p>
Plug-in connector with fixed connector housing (MHP093, MHP095, MHP112 and MHP115)	 <p>power cable</p> <p>Feedback cable</p> <p>Feedback cable</p> <p>power cable</p> <p>Feedback cable</p> <p>power cable</p> <p>power cable</p> <p>Feedback cable</p> <p>(state at delivery)</p> <p>power cable</p> <p>Feedback cable</p> <p>O03MHP.fh7</p>

Fig. 4-16: Possible outgoing directions of the electrical power connection

With MHP041, MHP071 and MHP090 motors, the outgoing direction can be set when mounting over a range of 270°. With MHP093, MHP112 and MHP115 motors, this direction is set at the time the order is placed.

Note: The outgoing direction specified in the order for MHP093, MHP112 and MHP115 motors can be changed at the time of mounting. See section 15 „Power connector” for details.

Feedback connector With MHP041, MHP071 and MHP090 motors, the outgoing direction of the feedback connector can be set at mounting over a range of 270° - possibly only restricted by the outgoing direction of the power connection. If feedback cables with angle feedback connectors are used in MHP093, MHP112 and MHP115 motors, then the outgoing direction of the feedback cable must be the B side of the motor.

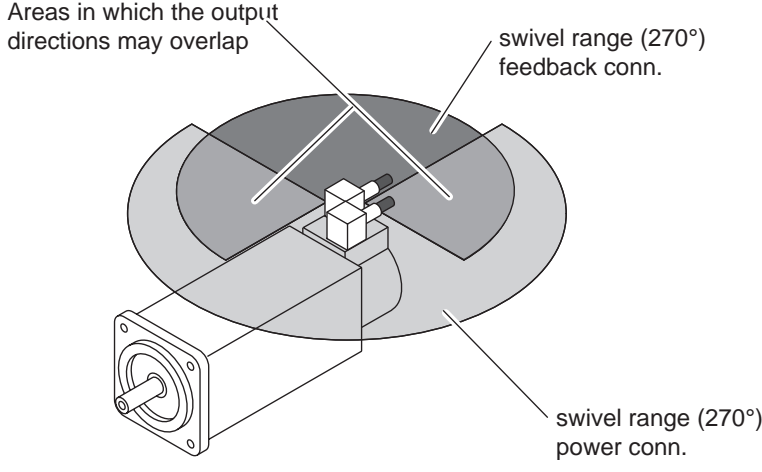
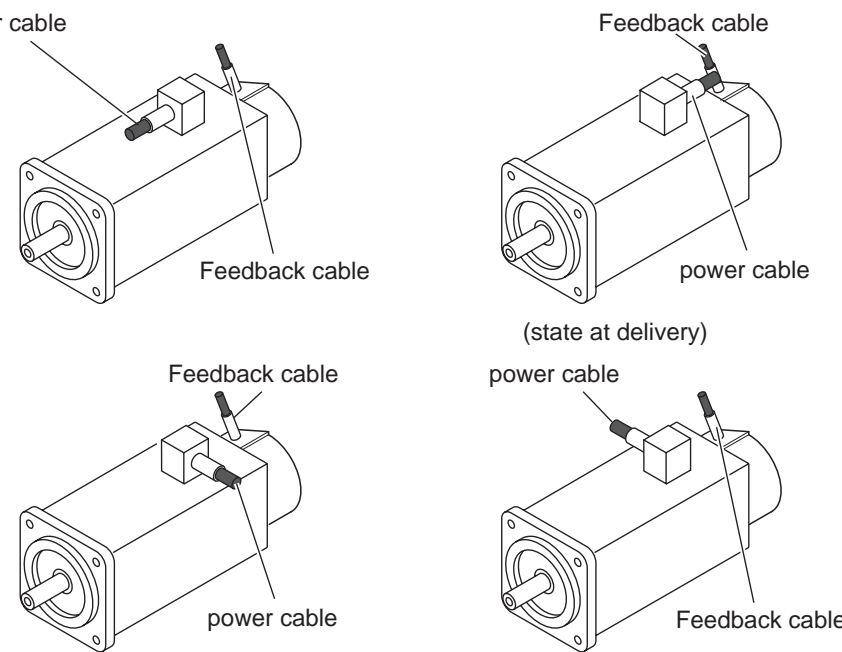
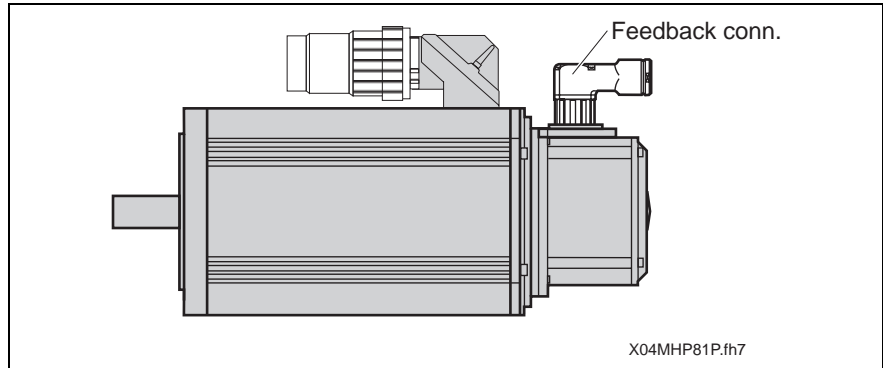

Fig. 4-17: MHP motor with angle feedback connector

Note: The cable outgoing direction of the angle feedback connector can be changed at mounting. See relevant section for details.

4.10 Speed/Torque Curves

The speed/torque curves are specified for two motor temperatures.

These are:

- $\Delta\vartheta 60$ K housing overtemperature and
- $\Delta\vartheta 100$ K windings overtemperature.

Structure of and measuring the $\Delta\vartheta 60$ K curve

The motor data and curves for MHP motors are fixed under the following conditions:

- Ambient temperature approx. 45°C
- Insulated construction (aluminum flange)
- Allowed housing overtemperature $\Delta\vartheta 60$ K
- For motors with holding brakes the data for motors with holding brake are always specified.
- Motors with shaft seal

Structure of and measuring the $\Delta\vartheta 100$ K curve

The motor data and curves for MHP motors are fixed under the following conditions:

- Ambient temperature approx. 40°C
- Non-insulated construction (mounted to steel flange LxWxH 450x30x350; MHP041 LxWxH 120x40x100)
- Allowed Windings overtemperature $\Delta\vartheta 100$ K
- For motors with holding brakes the data for motors with holding brake are always specified.
- Motors with shaft seal.

Note: If machine precision is negatively effected by the increased length expansion at $\Delta\vartheta 100\text{ K}$, then when projecting the facility work with the $\Delta\vartheta 60\text{ K}$ curves.

The torque/speed curves (see section **MHP...**) illustrate:

- torque limit data
- speed limit data and
- operating curves

Sections 7 to 13 „Torque/speed cures“ outlined a diagram for each motor.

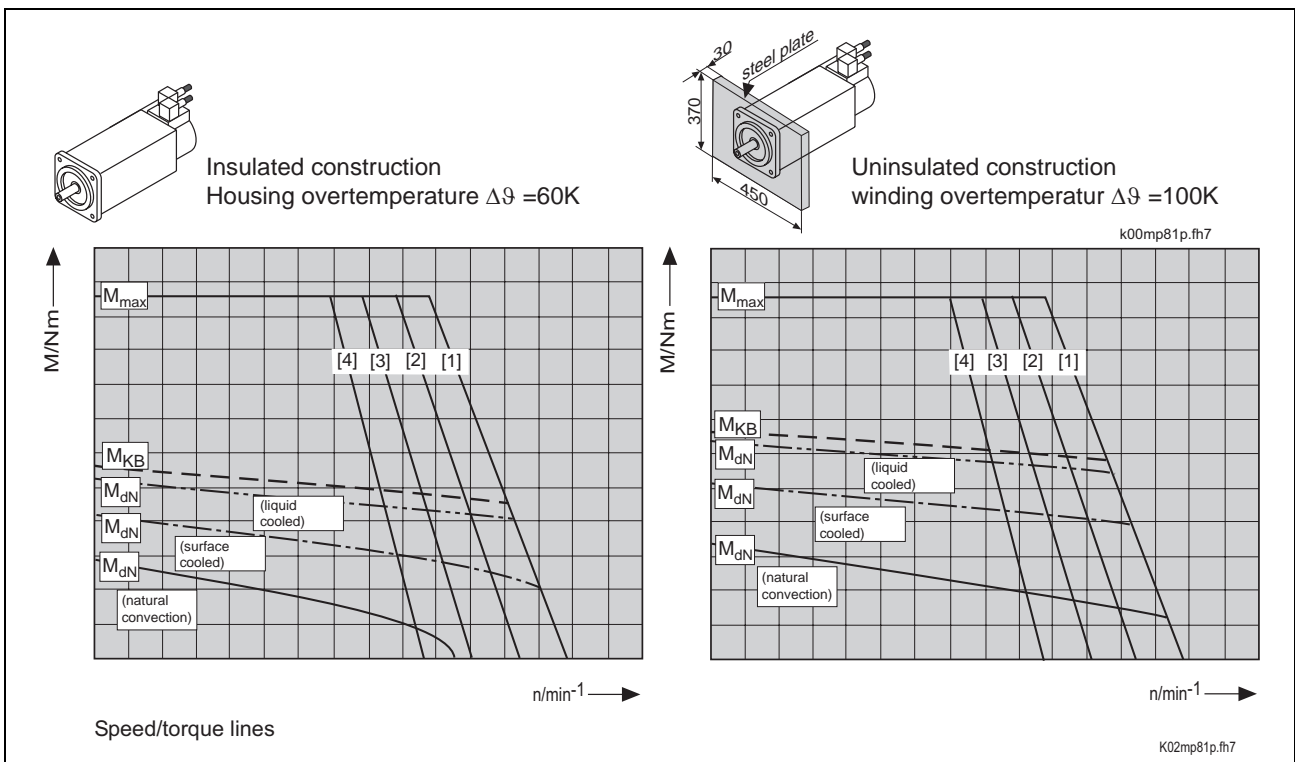

Fig. 4-18: Example diagram for understanding speed/torque curves

⇒ Use the diagram to:

- Determine maximum user speed with known torque demands.
- Check whether the thermal limits of the motor are maintained. This means that the rms torque achieved with a limit cycle lies below the S1 continuous operating curve (M_{dN}) of the arithmetically determined speed (arithmetic average).
- Enter the data from the selection lists in the selection document.

M_{max} Corresponds to the theoretically possible maximum torque of the motor. Can be limited by the drive controller.

Note: The maximum torque of a **motor/torque combination** is always listed in the selection list of the selection document.

M_{KB} S6 intermittent operating curve at 25% ON time of the motor (per DIN VDE 0530, edition dated 07/1991). Maximum duty cycle time equals 15 minutes.

M_{dN} S1 continuous operating curve of motor (per DIN VDE 0530, edition dated 07/1991).

Curve (1) to (4) As of a "knee" speed the maximum achievable usable speed depends on the available torque. As maximum motor speed is fixed by the DC bus voltage used, there are separate curves for each controller corresponding to the power supply unit used and possibly its connecting voltage.

(1) **HDS** or **HDD mounted** to power supply units **HVR**

(2) **HDS** or **HDD mounted** to power supply units **HVE** with mains connection of **3 x AC 480 V**.

(3) **HDS** or **HDD mounted** to power supply units **HVE** with mains connection of **3 x AC 440 V**.

(4) **HDS** or **HDD mounted** to power supply units **HVE** with mains connection of **3 x AC 400 V**.

Note: The characteristics (2-4) indicated in section 7 to 13 are "worst case" details on the production tolerances. The given characteristics must be reduced linearly at net undervoltage.

5 Electrical Connections

5.1 An Overview of the Connections

The electrical connections of Rexroth Indramat drives are standardized. On MHP AC motors there are:

- a power connection which includes a connection for a temperature sensor and a holding brake and
- a feedback connection.

Both connections are separate plug-in connectors. For details about outgoing directions, see section 4.6.

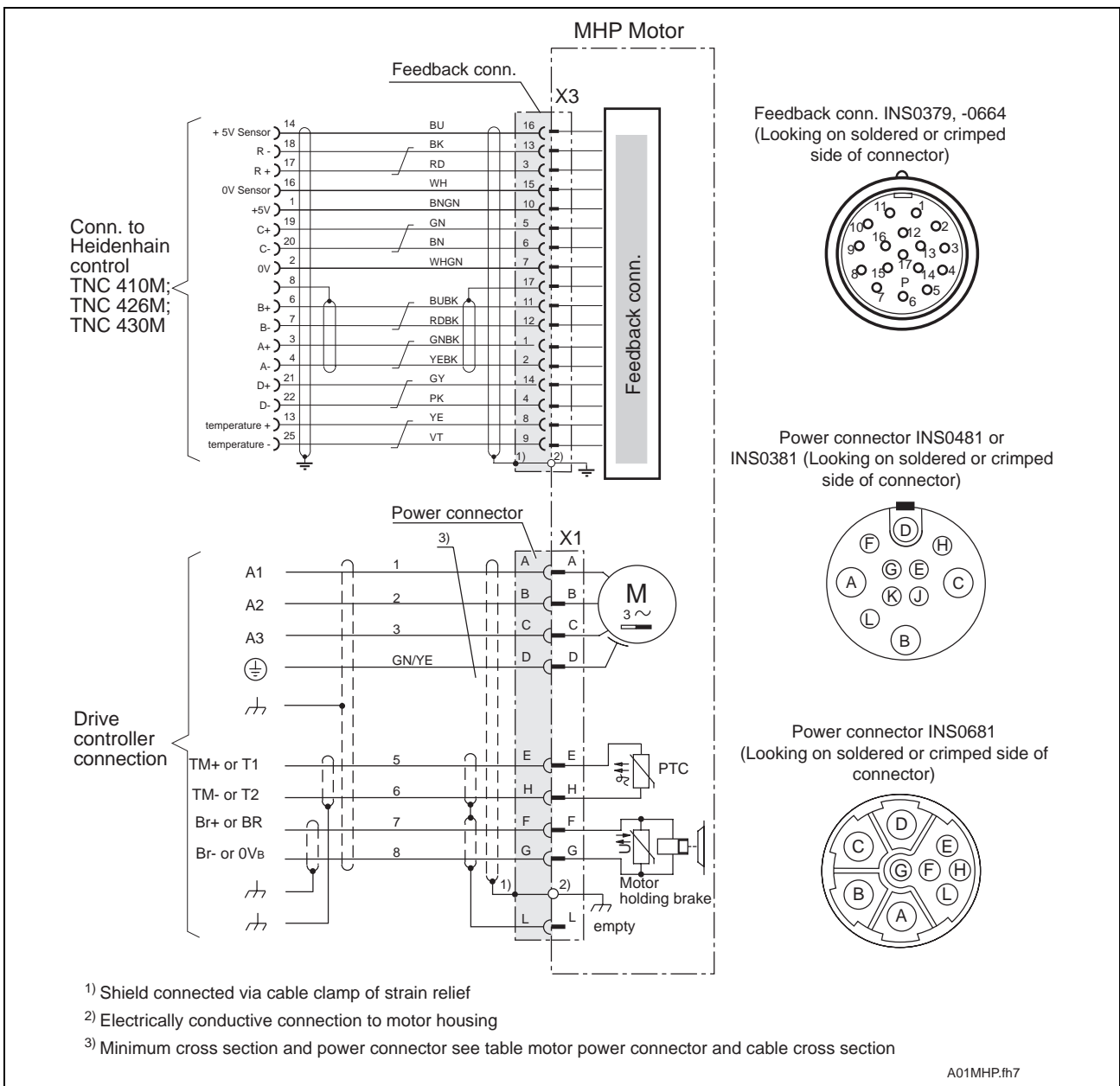

Fig. 5-1: Connection diagram for MHP motors

For motors with surface cooling, use own cables to connect the motor blower. For details on this connection and mounting of the blower connector, see section 4.

5.2 Power Cable

MHP motors are generally equipped with standard power cables.

These power cables are available:

- for direct connections
- or connections with intermediate plug-in points

The following table lists cable type designations (order designations) for various motor/controller combinations.

Selecting the power cable	All MHP motors presently available are listed below. Find in the list: <ol style="list-style-type: none">1. The motor type needed allowing for cooling mode.2. The minimum cross section of needed power cable allowing for operating mode.3. Cross reference (Fig:x.x) to view relevant graphics.4. Select in graphics the needed cable and its order number.5. Order cable following the example below.
Selecting the length	Available cable lengths are 2 to 75 meters.
Order example	To order simply specified cable type with desired length. Example: IKG4017 / 10.5 (=Power cable for HDS12.x, length 10.5m).

Note: The maximum total length of the cable connection from motor to controller with two intermediate plug-in points equals 75 meters. Maximum length could drop with more plug-in points. Such a connection should also be tested.

Motor type	Cooling mode	Motor connection	Motor phase current I _{Str(eff)} [A]		Minimum cross section ¹⁾ mm ²		For selection see	
			oper. mode	60K	100K	60K	100K	60K
041A-144	natural convection	INS0680	2.3	i.p.	1.0	i.p.	Fig. 5-3	i.p.
041B-144	natural convection	INS0680	5.0	i.p.	1.0	i.p.	Fig. 5-3	i.p.
071A-061	natural convection	INS0680	3.4	i.p.	1.0	i.p.	Fig. 5-3	i.p.
071B-035	natural convection	INS0680	4.3	i.p.	1.0	i.p.	Fig. 5-3	i.p.
	surface cooled	INS0680	6.5	6.5	1.0	1,0	Fig. 5-3	Fig. 5-3
071B-061	natural convection	INS0680	7.7	8.9	1.0		Fig. 5-3	Fig. 5-3
	surface cooled	INS0680	11.6	11.6	1.0	1,0	Fig. 5-3	Fig. 5-3
090B-035	natural convection	INS0680	7.7	9.0	1.0		Fig. 5-3	Fig. 5-3
	surface cooled	INS0680	11.6	11.6	1.0		Fig. 5-3	Fig. 5-3
090B-058	natural convection	INS0680	12.3	i.p.	1.0	i.p.	Fig. 5-3	i.p.
	surface cooled	INS0680	18.5	18.5	2.5		Fig. 5-5	Fig. 5-5
093A-024	natural convection	INS0480	5.3	i.p.	1.5 ²⁾	i.p.	Fig. 5-6	i.p.
093A-035	natural convection	INS0480	7.3	i.p.	1.5 ²⁾	i.p.	Fig. 5-6	i.p.
093A-058	natural convection	INS0480	8.9	i.p.	1.5 ²⁾	i.p.	Fig. 5-6	i.p.
093B-035	natural convection	INS0480	8.8	10.3	1.5 ²⁾	1.5 ²⁾	Fig. 5-6	Fig. 5-6
	surface cooled	INS0480	13.2	13.2	1.5	1.5	Fig. 5-6	Fig. 5-6
	liquid cooled	INS0480	16.7	16.7	2.5	2.5	Fig. 5-7	Fig. 5-7
093B-058	natural convection	INS0480	15.0	18.5	1.5	2.5	Fig. 5-6	Fig. 5-7
	surface cooled	INS0480	22.5	22.5	4.0	4.0	Fig. 5-8	Fig. 5-8
	liquid cooled	INS0480	28.5	28.5	4.0	4.0	Fig. 5-8	Fig. 5-8
093C-035	natural convection	INS0480	12.4	15.5	1.5 ²⁾	1.5	Fig. 5-6	Fig. 5-6
	surface cooled	INS0480	18.6	18.6	2.5	2.5	Fig. 5-7	Fig. 5-7
	liquid cooled	INS0480	23.6	23.6	4.0	4.0	Fig. 5-8	Fig. 5-8
093C-058	natural convection	INS0480	18.9	23.6	2.5	4.0	Fig. 5-7	Fig. 5-8
	surface cooled	INS0480	28.4	28.4	4.0	4.0	Fig. 5-8	Fig. 5-8
	liquid cooled	INS0480	35.9	35.9	6.0	6.0	Fig. 5-9	Fig. 5-9
095A-024	natural convection	INS0480	i.p.	i.p.	i.p.	i.p.	i.p.	i.p.
095A-035	natural convection	INS0480	7.7	9.4	1.5 ²⁾	1.5 ²⁾	Fig. 5-6	Fig. 5-6
095A-058	natural convection	INS0480	i.p.	i.p.	i.p.	i.p.	i.p.	i.p.
095B-035	natural convection	INS0480	10.9	13.5	1.5 ²⁾	1.5	Fig. 5-6	Fig. 5-6
	surface cooled	INS0480	16.4	16.4	2.5	2.5	Fig. 5-7	Fig. 5-7
	liquid cooled	INS0480	20.7	20.7	2.5	2.5	Fig. 5-7	Fig. 5-7
095B-058	natural convection	INS0480	i.p.	i.p.	i.p.	i.p.	i.p.	i.p.
	surface cooled	INS0480	i.p.	i.p.	i.p.	i.p.	i.p.	i.p.
	liquid cooled	INS0480	i.p.	i.p.	i.p.	i.p.	i.p.	i.p.
095C-035	natural convection	INS0480	14.0	17.5	1.5	2.5	Fig. 5-6	Fig. 5-7
	surface cooled	INS0480	21.0	21.0	2.5	2.5	Fig. 5-7	Fig. 5-7
	liquid cooled	INS0480	26.6	26.6	4.0	4.0	Fig. 5-8	Fig. 5-8
095C-058	natural convection	INS0480	i.p.	i.p.	i.p.	i.p.	i.p.	i.p.
	surface cooled	INS0480	i.p.	i.p.	i.p.	i.p.	i.p.	i.p.
	liquid cooled	INS0480	i.p.	i.p.	i.p.	i.p.	i.p.	i.p.
112A-024	natural convection	INS0480	9.2	i.p.	1.5 ²⁾	i.p.	Fig. 5-6	i.p.
112A-058	natural convection	INS0480	12.1	i.p.	1.5 ²⁾	i.p.	Fig. 5-6	i.p.

Continued on next page

Motor type	Cooling mode	Motor connection	Motor phase current $I_{Str(eff)}$ [A]		Minimum cross section ¹⁾ mm ²		For selection see	
			60K	100K	60K	100K	60K	100K
		oper. mode	60K	100K	60K	100K	60K	100K
112B-024	natural convection	INS0480	15.4	17.6	1.5	2.5	Fig. 5-6	Fig. 5-7
	surface cooled	INS0480	23.1	23.1	4.0	4.0	Fig. 5-8	Fig. 5-8
112B-035	natural convection	INS0480	i.p.	i.p.	i.p.	i.p.	i.p.	i.p.
	surface cooled	INS0480	i.p.	i.p.	i.p.	i.p.	i.p.	i.p.
112B-058	natural convection	INS0480	28.5	32.6	4.0	6.0	Fig. 5-8	Fig. 5-9
	surface cooled	INS0480	42.8	42.8	10.0	10.0	Fig. 5-10	Fig. 5-10
112C-024	natural convection	INS0480	18.6	22.0	2.5	2.5	Fig. 5-7	Fig. 5-7
	surface cooled	INS0480	27.9	27.9	4.0	4.0	Fig. 5-8	Fig. 5-8
112C-035	natural convection	INS0480	22.6	26.8	4.0	4.0	Fig. 5-8	Fig. 5-8
	surface cooled	INS0480	33.9	33.9	6.0	6.0	Fig. 5-9	Fig. 5-9
112C-058	natural convection	INS0380	37.7	44.6	6.0	10.0	Fig. 5-11	Fig. 5-12
	surface cooled	INS0380	56.6	56.6	16.0	16.0	Fig. 5-13	Fig. 5-13
112D-027	natural convection	INS0480	22.2	27.3	2.5	4.0	Fig. 5-6	Fig. 5-8
	surface cooled	INS0480	33.3	33.3	6.0	6.0	Fig. 5-9	Fig. 5-9
115A-024	natural convection	INS0380	14.4	i.p.	6.0 ³⁾	i.p.	Fig. 5-11	i.p.
	liquid cooled	INS0380	27.4	27.4	6.0 ³⁾	6.0 ³⁾	Fig. 5-11	Fig. 5-11
115A-058	natural convection	INS0380	24.3	i.p.	6.0 ³⁾	i.p.	Fig. 5-11	i.p.
	liquid cooled	INS0380	46.2	46.2	10.0	10.0	Fig. 5-12	Fig. 5-12
115B-024	natural convection	INS0380	22.0	i.p.	6.0 ³⁾	i.p.	Fig. 5-11	i.p.
	surface cooled	INS0380	33.0	33.0	6.0 ³⁾	6.0 ³⁾	Fig. 5-11	Fig. 5-11
	liquid cooled	INS0380	41.8	41.8	10.0	10.0	Fig. 5-12	Fig. 5-12
115B-058	natural convection	INS0380	41.4	i.p.	10.0	i.p.	Fig. 5-12	i.p.
	surface cooled	INS0380	62.1	62.1	16.0	16.0	Fig. 5-13	Fig. 5-13
	liquid cooled	INS0380	78.7	78.7	25.0	25.0	Fig. 5-14	Fig. 5-14
115C-024	natural convection	INS0380	31.6	i.p.	6.0 ³⁾	i.p.	Fig. 5-11	i.p.
	surface cooled	INS0380	47.4	47.4	10.0	10.0	Fig. 5-12	Fig. 5-12
	liquid cooled	INS0380	60.0	60.0	16.0	16.0	Fig. 5-13	Fig. 5-13
115C-058	natural convection	INS0380	54.6	i.p.	16.0	i.p.	Fig. 5-13	i.p.
	surface cooled	INS0380	81.9	81.9	25.0	25.0	Fig. 5-14	Fig. 5-14
	liquid cooled	INS0380	103.7	103.7	35.0	35.0	Fig. 5-15	Fig. 5-15

1) Line cross section per DIN EN 60204, B2 installation type and conversion factor for Rexroth Indramat cable with ambient temp. of 40°C.

2) Smallest connection cross section (crimp contact) of connectors INS0480, -481, -483 is 1.5 mm².

3) Smallest connection cross section (crimp contact) of connectors INS0380, -381 is 6.0 mm².

Fig. 5-2: Motor overview for selecting motor power cables for an MHP

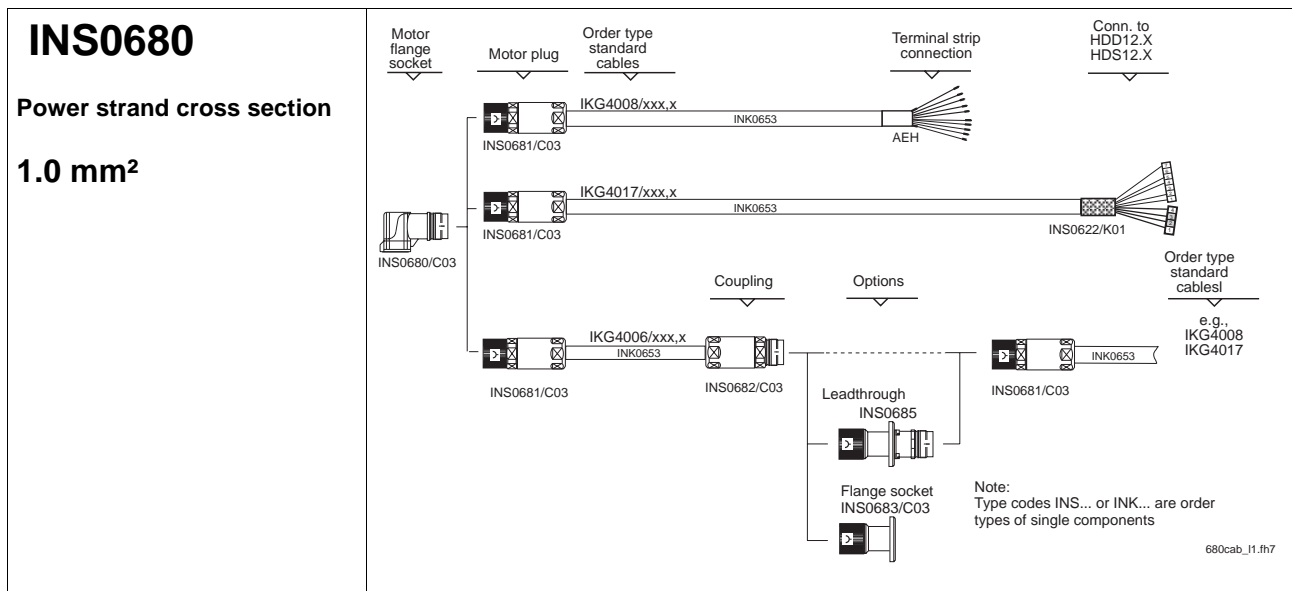

Fig. 5-3: Motor power cable 1.0 mm² of flange socket INS0680

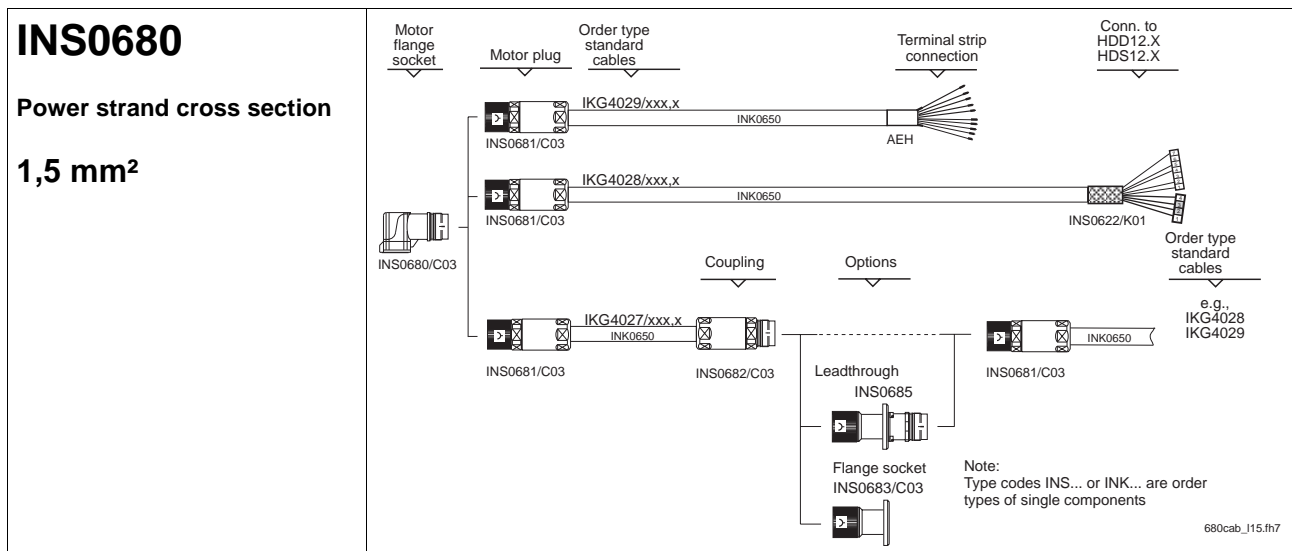

Fig. 5-4: Motor power cable 1.5 mm² of flange socket INS0680

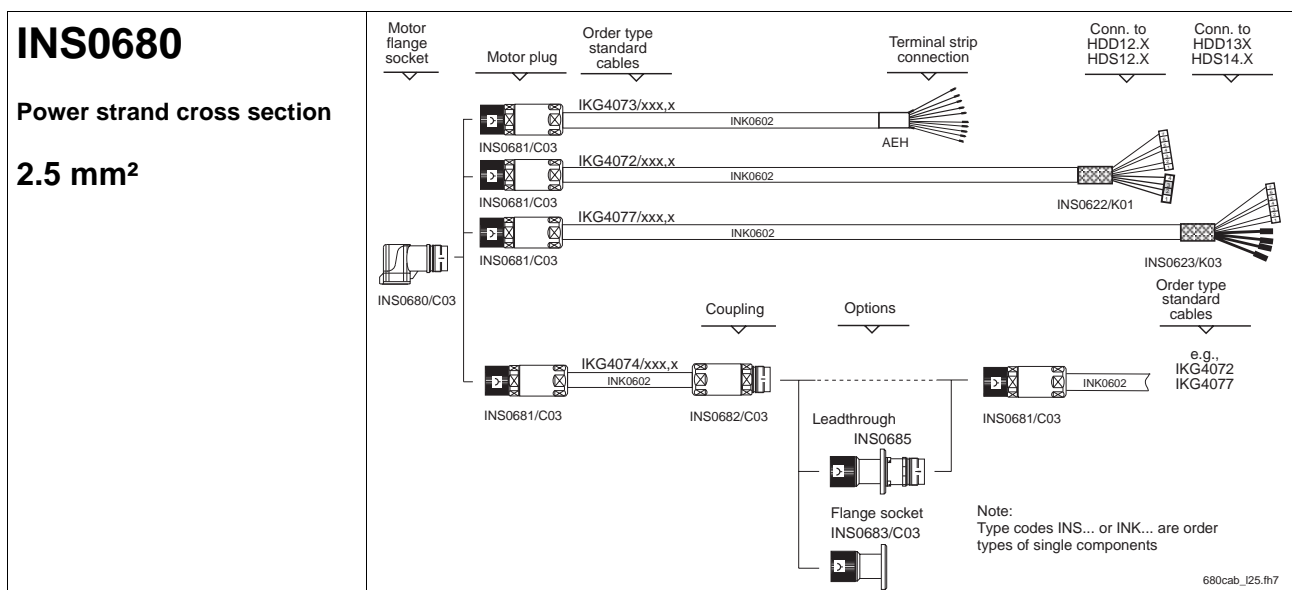

Fig. 5-5: Motor power cable 2.5 mm² of flange socket INS0680

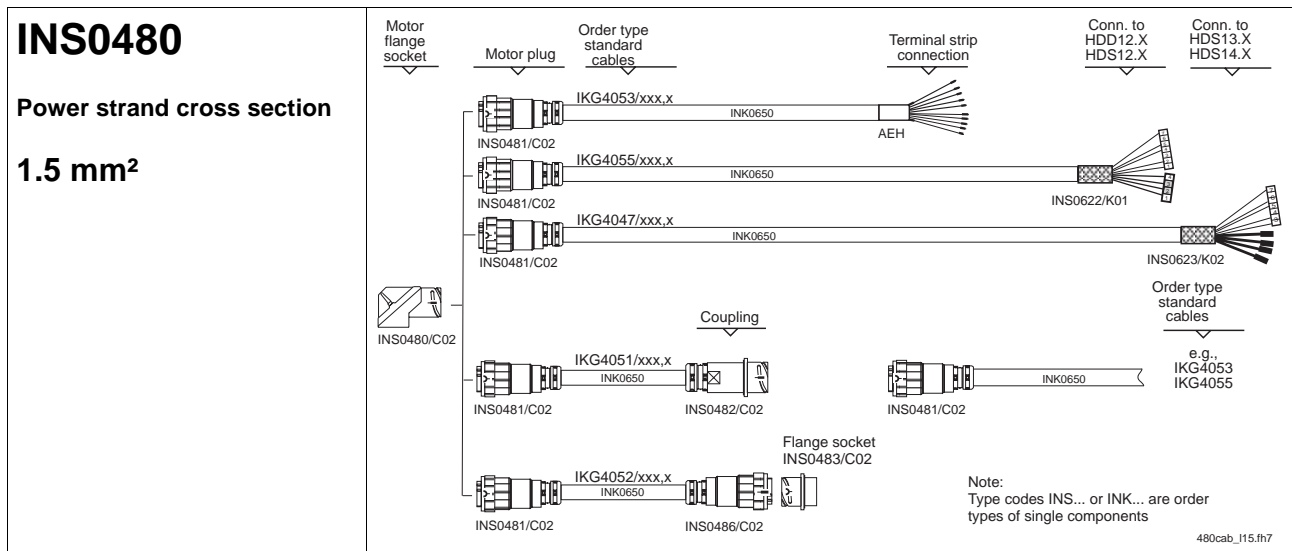

Fig. 5-6: Motor power cable 1.5 mm² of flange socket INS0480

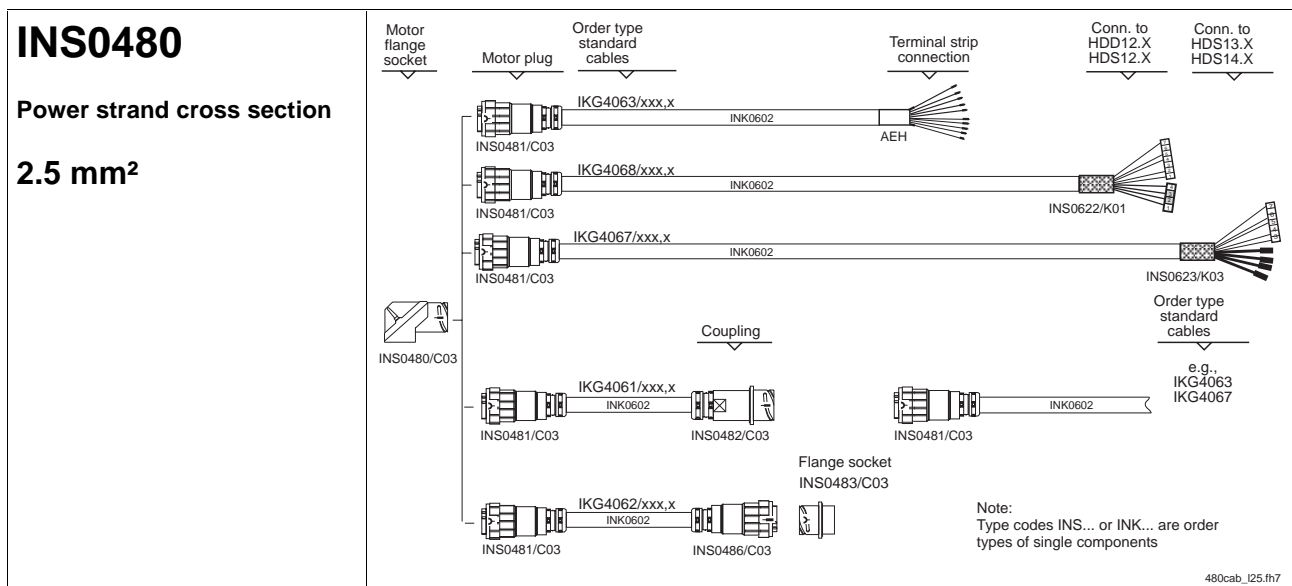

Fig. 5-7: Motor power cable 2.5 mm² of flange socket INS0480

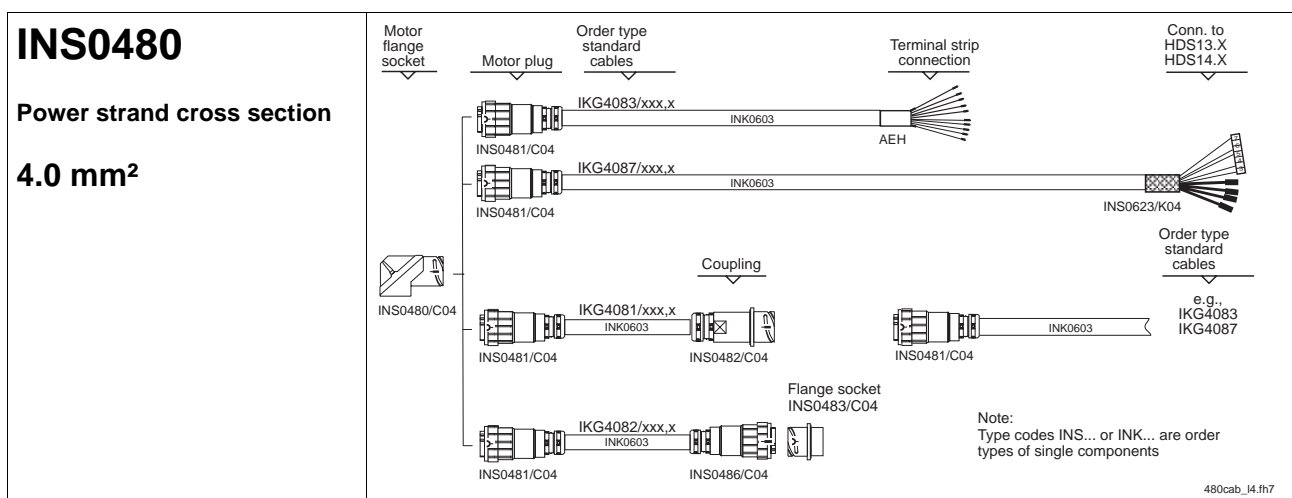

Fig. 5-8: Motor power cable 4.0 mm² of flange socket INS0480

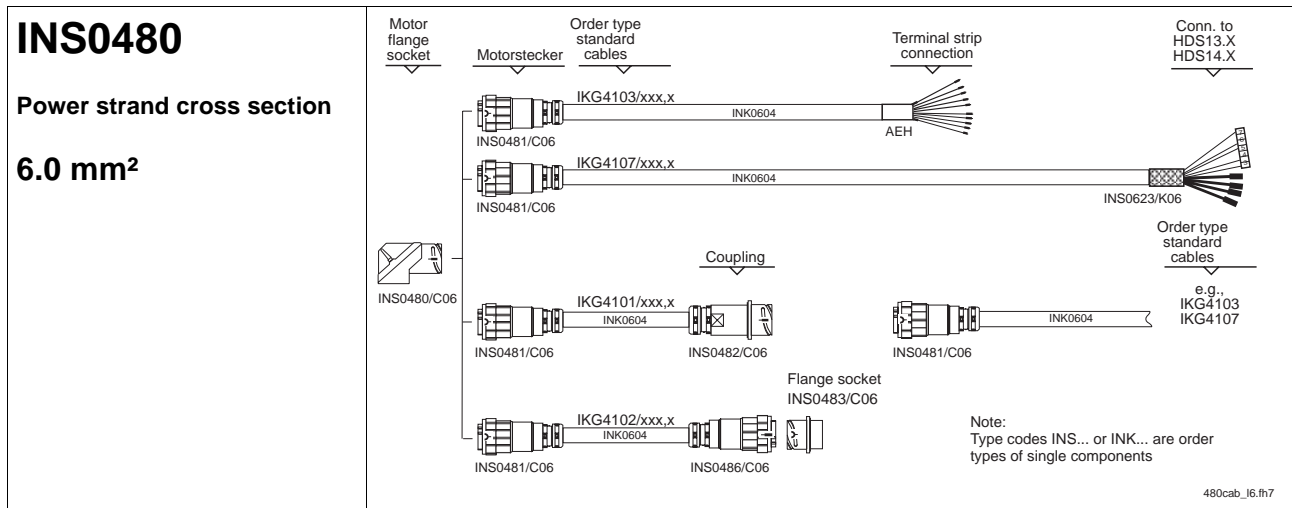

Fig. 5-9: Motor power cable 6.0 mm² of flange socket INS0480

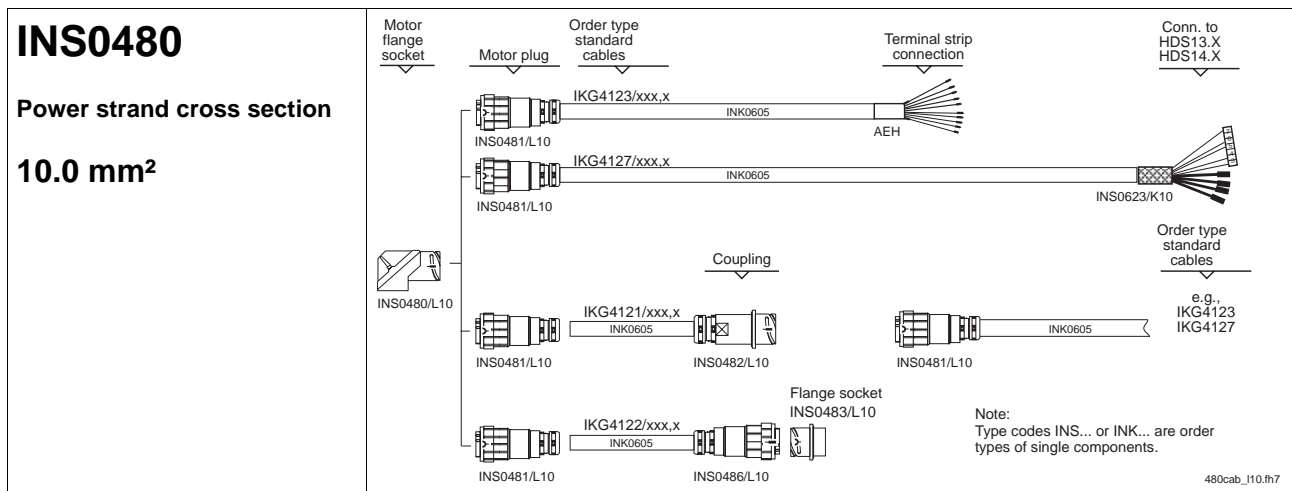

Fig. 5-10: Motor power cable 10.0 mm² of flange socket INS0480

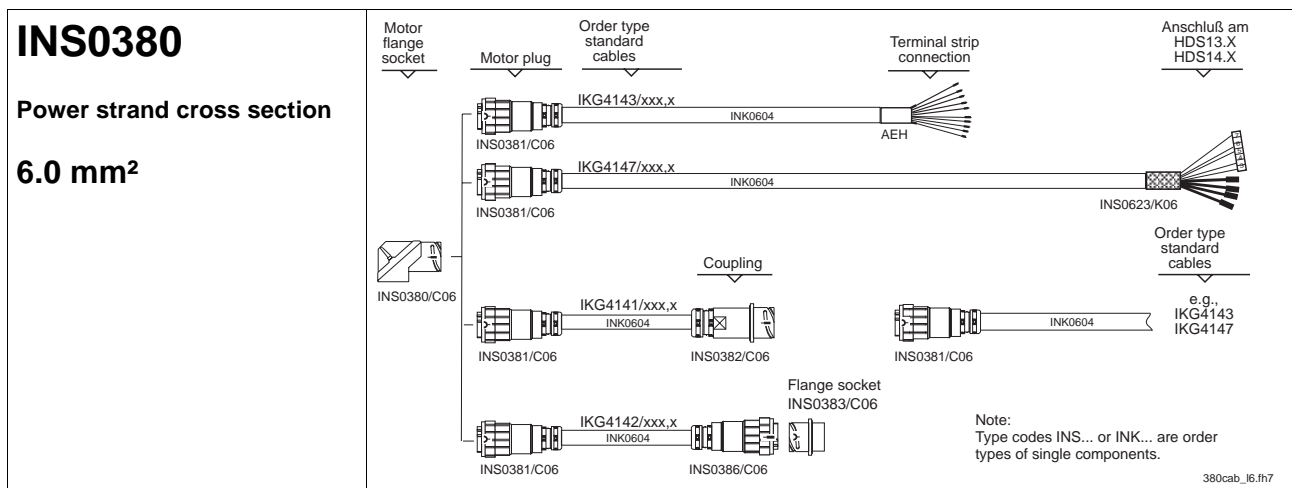

Fig. 5-11: Motor power cable 6.0 mm² of flange socket INS0380

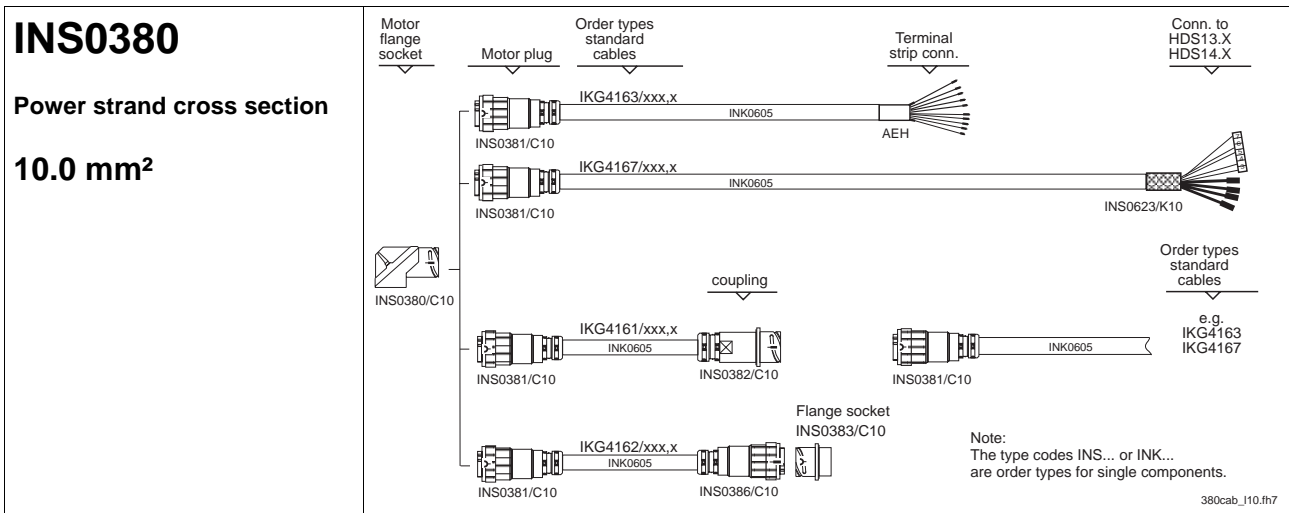

Fig. 5-12: Motor power cable 10.0 mm² of flange socket INS0380

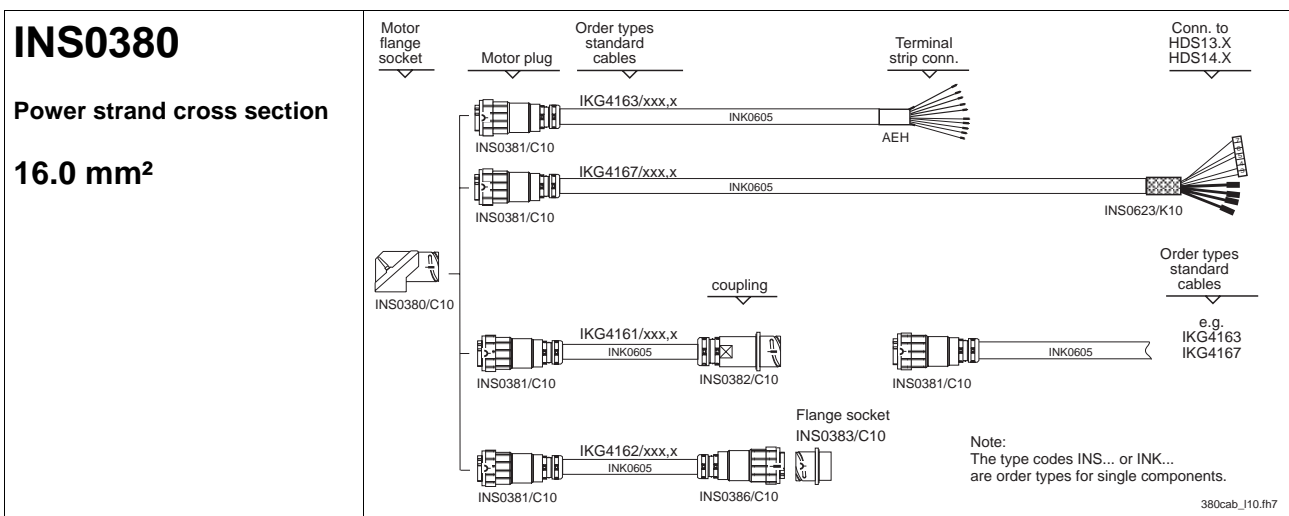

Fig. 5-13: Motor power cable 16.0 mm² of flange socket INS0380

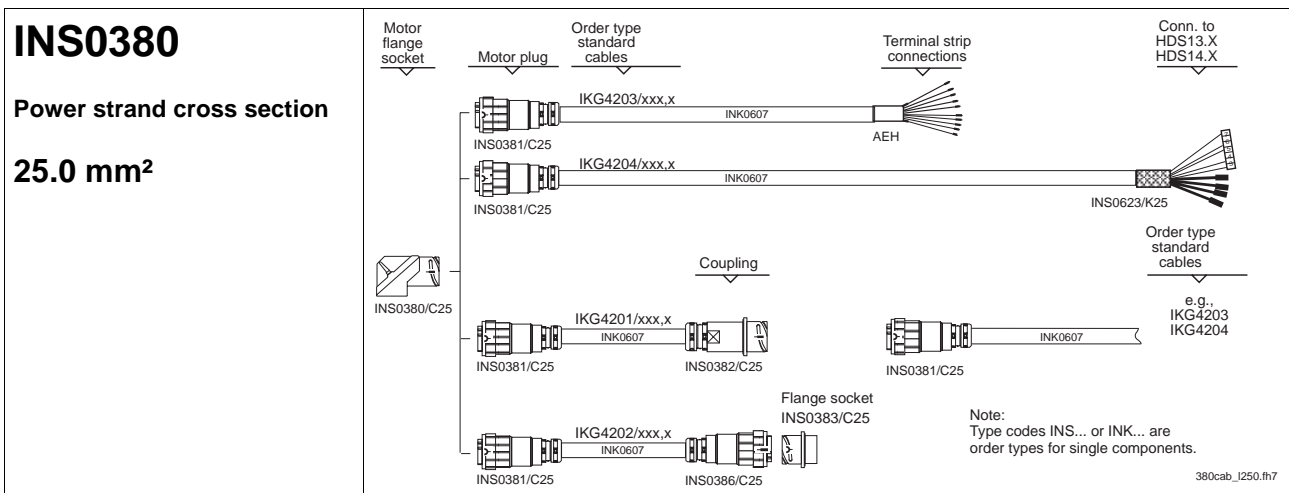

Fig. 5-14: Motor power cable 25.0 mm² of flange socket INS0380

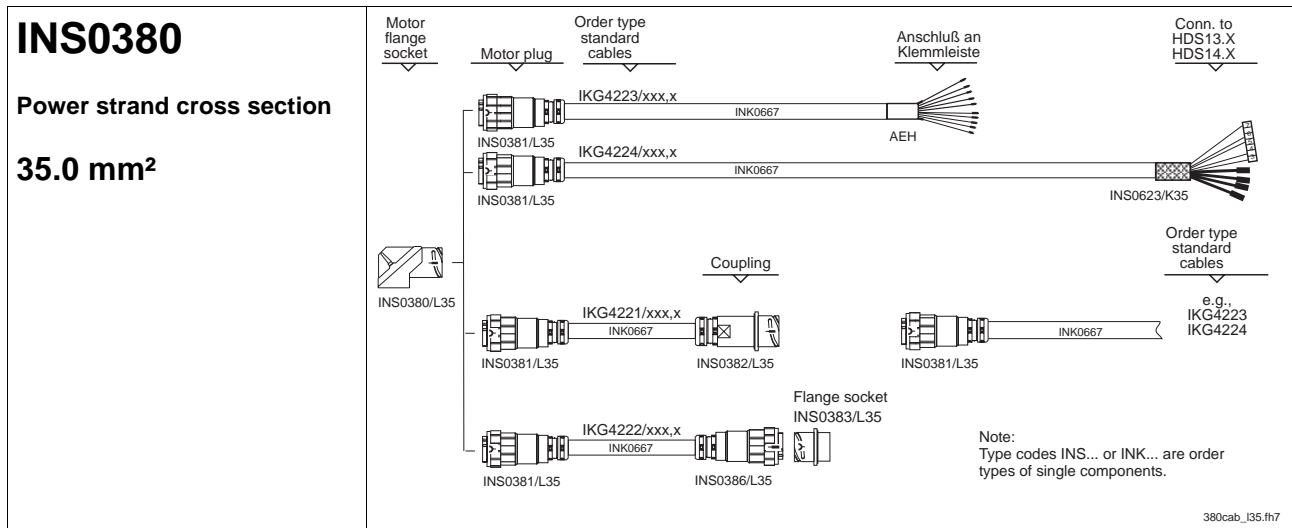

Fig. 5-15: Motor power cable 35.0 mm² of flange socket INS0380

5.3 Feedback cable

MHP motors are preferably outfitted with standard feedback cables.

These feedback cables are, as are the power cables, available for „direct connections“ and „connections with intermediate plug-in locations“ in the following versions:

- version „straight“
- version „angled“

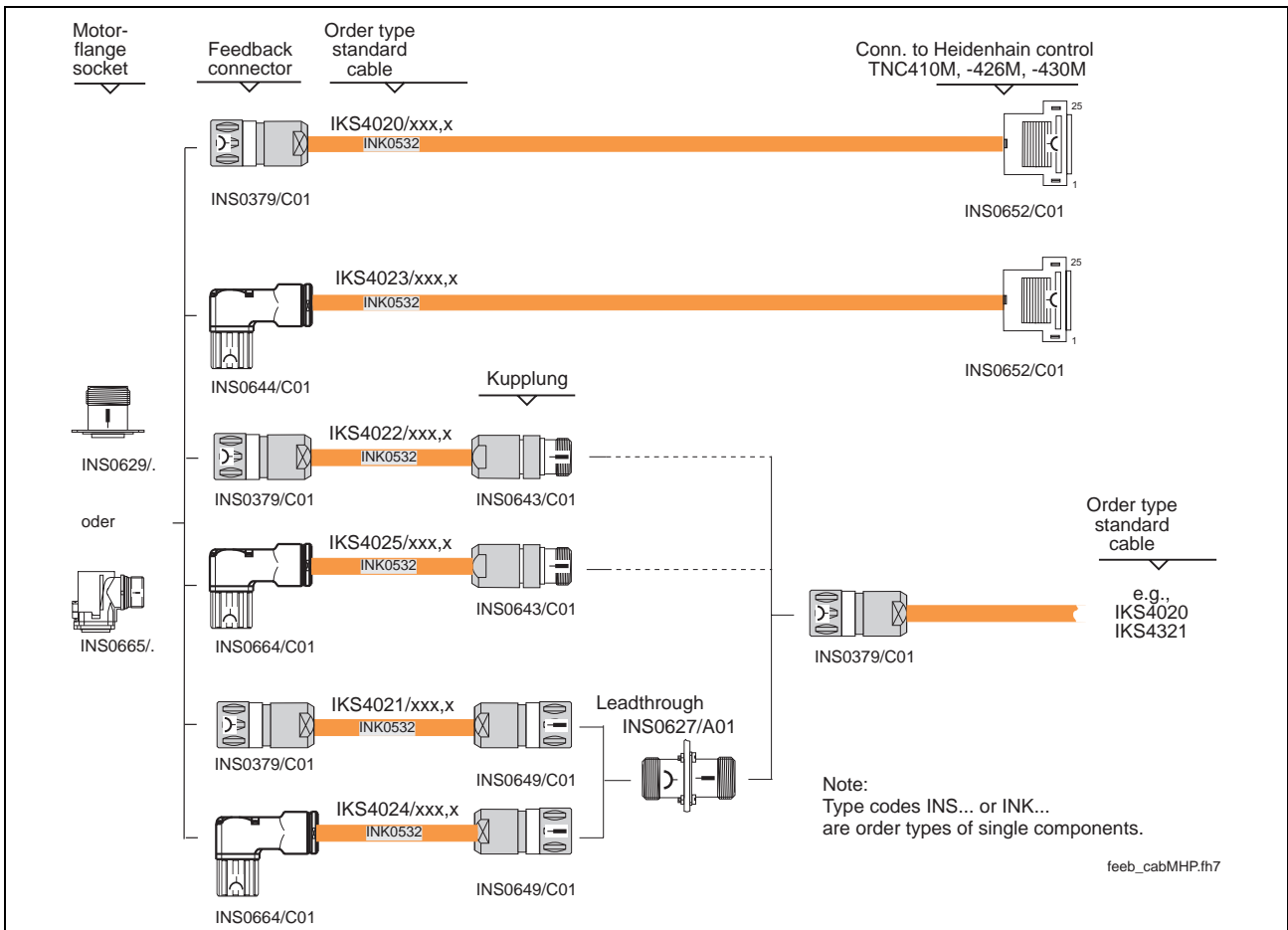

Fig. 5-16: Standard feedback cable

Using Fig. 5-16: Standard feedback cable select either the cable or cable combination that suits your motor/controller combination.

Selecting the length

Available cable lengths: **any** in 0.5m increments up to a maximum of 75 meters.

⇒ When ordering, simply state cable type and length wanted.
 Example: **IKS4020 / 5,5** (= feedback cable, length 5.5m).

Note: The maximum total length of the cable connection from motor to drive controller with two intermediate plug-in locations equals 75 meters. Given a greater number, then the maximum total length could be shorter. This should also be tested.

5.4 Technical data of Power and Feedback cable

Name	Unit	Data									
		IKG	IKG	IKG	IKG	IKG	IKG	IKG	IKG	IKG	IKS
Type designation of standard cable IKG... or IKS...		4006 4007 4008 4009 4055 4060	4047 4051 4052 4053	4061 4062 4063 4067 4068 4070	4081 4082 4083 4087 4090	4101 4102 4103 4107 4110 4141 4142 4143 4147 4150	4121 4122 4123 4127 4130 4161 4162 4163 4167 4170	4181 4182 4183 4186	4201 4202 4203 4204	4221 4222 4223 4224	4020 4021 4022 4023 4024
Type designation cable (non-standard) INK...		0653	0650	0602	0603	0604	0605	0606	0607	0667	0532
Power or power supply strand cross section	mm ²	4 x 1.0	4 x 1.5	4 x 2.5	4 x 4.0	4 x 6.0	4 x 10.0	4 x 16.0	4 x 25.0	4 x 35.0	4 x 1.0
Control core cross section (holding brake, temperature monitor or control voltage)	mm ²	2 x (2 x 0.75)	2 x (2 x 0.75)	2 x (2 x 1.0)	(2 x 1.0) + (2 x 1.5)	(2 x 1.0) + (2 x 1.5)	(2 x 1.0) + (2 x 1.5)	2 x (2 x 1.5)	2 x (2 x 1.5)	2 x (2 x 1.5)	4 x (2 x 0.14) + 4 x 0.14
Diameter	mm	12.0 ±0.5	12.2 ±0.5	15.0 ±0.8	17.8 ±0.6	18.6 ±0.8	22.5 ±1.0	27.6 ±0.8	30.4 ±0.8	32.4 ±0.9	9.7 ±0.3
Minimum bend radius with fixed routing with flexible routing	mm mm	75 120	85 140	95 160	100 180	140 190	170 230	190 280	210 300	230 320	60 100
Number of bends (in million)		2	2	2	2	2	2	2	2	2	2
Specific cable weight	kg/m	0.22	0.24	0.33	0.49	0.59	0.87	1.31	1.72	2.16	0.15
Construction		Accommodates continuous bend requirements									
Burn behavior		Meets demands as per VDE0472, section 804									
Chemical features		resistant to mineral oils and greases; hydrolysis resistant, silicone and halogen free									
Approbation		UL and CSA listed									
Allowed ambient temperature for storage	°C	-30 to +80									
Continuous operating temperature for fixed routing flexible routing	°C	-30 to +90 -30 to +80									
Cable sheath -material -color		Surface dull with poor adhesive qualities PUR orange									

Fig. 5-17: Technical data of power and feedback cable for MHP motors

5.5 Individual Parts

Individual Parts for Making INDRAMAT Power Cables

Note: INDRAMAT cables can be made by the user. All needed information about

- INDRAMAT raw cable types
- precise mounting instructions
- and tools

are in the document „Indramat Internal Connection System, Assembly and Tools“; DOK-CONN-CAB*INSTR02-MA01-EN-P.

Selecting power connectors and cable cross sections

⇒ The following selection list outlines which motor power connector and cross section should be used with which MHP motor.

Note: When selecting, note the operating mode in which the motor should be run (ΔT_{60K} or ΔT_{100K}).

⇒ Motor power connectors are available either crimped or soldered.

⇒ Appropriate strain reliefs for cables should be mounted into the motor power connectors. The dimensions of the connector conduit thread is specified in sections 7 through 13, “Dimensional data”.

Motor type	Cooling mode	Motor phase current $I_{Str(eff)}$ [A]		Cross section ¹⁾ Power connection [mm ²]		Crimp INS...		Solder INS...	
		60K	100K	60K	100K	60K	100K	60K	100K
041A-144	natural convection	2.3	i/p	1.0	i/p	0681/C03	i/p	---	---
041B-144	natural convection	5.0	i/p	1.0	i/p	0681/C03	i/p	---	---
071A-061	natural convection	3.4	i/p	1.0	i/p	0681/C03	i/p	---	---
071B-035	natural convection	4.3	i/p	1.0	i/p	0681/C03	i/p	---	---
	surface cooled	6.5	6.5	1.0	1.0	0681/C03	0681/C03	---	---
071B-061	natural convection	7.7	8.9	1.0		0681/C03	i/p	---	---
	surface cooled	11.6	11.6	1.0	1.0	0681/C03	0681/C03	---	---
090B-035	natural convection	7.7	9.0	1.0	1.0	0681/C03	0681/C03	---	---
	surface cooled	11.6	11.6	1.0		0681/C03	0681/C03	---	---
090B-058	natural convection	12.3	i/p	1.0	i/p	0681/C03	i/p	---	---
	surface cooled	18.5	18.5	2.5	2.5	0681/C03	0681/C03	---	---
093A-024	natural convection	5.3	i/p	1.5 ²⁾	i/p	0481/C02	i/p	0481/L10	i/p
093A-035	natural convection	7.3	i/p	1.5 ²⁾	i/p	0481/C02	i/p	0481/L10	i/p

Continued on next page

Motor type	Cooling mode	Motor phase current $I_{Str(eff)}$ [A]		Cross section ¹⁾ power conn. [mm ²]		Crimp INS...		Solder INS...	
		60K	100K	60K	100K	60K	100K	60K	100K
093A-058	natural convection	8.9	i/p	1.5 ²⁾	i/p	0481/C02	i/p	0481/L10	i/p
093B-035	natural convection	8.8	10.3	1.5 ²⁾	1.5 ²⁾	0481/C02	0481/C02	0481/L10	0481/L10
	surface cooled	13.2	13.2	1.5	1.5	0481/C02	0481/C02	0481/L10	0481/L10
	liquid cooled	16.7	16.7	2.5	2.5	0481/C03	0481/C03	0481/L10	0481/L10
093B-058	natural convection	15.0	18.5	1.5	2.5	0481/C02	0481/C03	0481/L10	0481/L10
	surface cooled	22.5	22.5	4.0	4.0	0481/C04	0481/C04	0481/L10	0481/L10
	liquid cooled	28.5	28.5	4.0	4.0	0481/C04	0481/C04	0481/L10	0481/L10
093C-035	natural convection	12.4	15.5	1.5 ²⁾	1.5	0481/C02	0481/C02	0481/L10	0481/L10
	surface cooled	18.6	18.6	2.5	2.5	0481/C03	0481/C03	0481/L10	0481/L10
	liquid cooled	23.6	23.6	4.0	4.0	0481/C04	0481/C04	0481/L10	0481/L10
093C-058	natural convection	18.9	23.6	2.5	4.0	0481/C03	0481/C04	0481/L10	0481/L10
	surface cooled	28.4	28.4	4.0	4.0	0481/C04	0481/C04	0481/L10	0481/L10
	liquid cooled	35.9	35.9	6.0	6.0	0481/C06	0481/C06	0481/L10	0481/L10
095A-024	natural convection	i/p	i/p	i/p	i/p	i/p	i/p	i/p	i/p
095A-035	natural convection	7.7	9.4	1.5 ²⁾	1.5 ²⁾	0481/C02	0481/C02	0481/L10	0481/L10
095A-058	natural convection	i/p	i/p	i/p	i/p	i/p	i/p	i/p	i/p
095B-035	natural convection	10.9	13.5	1.5 ²⁾	1.5	0481/C02	0481/C02	0481/L10	0481/L10
	surface cooled	16.4	16.4	2.5	2.5	0481/C03	0481/C03	0481/L10	0481/L10
	liquid cooled	20.7	20.7	2.5	2.5	0481/C03	0481/C03	0481/L10	0481/L10
095B-058	natural convection	i/p	i/p	i/p	i/p	i/p	i/p	i/p	i/p
	surface cooled	i/p	i/p	i/p	i/p	i/p	i/p	i/p	i/p
	liquid cooled	i/p	i/p	i/p	i/p	i/p	i/p	i/p	i/p
095C-035	natural convection	14.0	17.5	1.5	2.5	0481/C02	0481/C03	0481/L10	0481/L10
	surface cooled	21.0	21.0	2.5	2.5	0481/C03	0481/C03	0481/L10	0481/L10
	liquid cooled	26.6	26.6	4.0	4.0	0481/C04	0481/C04	0481/L10	0481/L10
095C-058	natural convection	i/p	i/p	i/p	i/p	i/p	i/p	i/p	i/p
	surface cooled	i/p	i/p	i/p	i/p	i/p	i/p	i/p	i/p
	liquid cooled	i/p	i/p	i/p	i/p	i/p	i/p	i/p	i/p
112A-024	natural convection	9.2	i/p	1.5 ²⁾	i/p	0481/C02	i/p	0481/L10	i/p
112A-058	natural convection	12.1	i/p	1.5 ²⁾	i/p	0481/C02	i/p	0481/L10	i/p
112B-024	natural convection	15.4	17.6	1.5	2.5	0481/C02	0481/C03	0481/L10	0481/L10
	surface cooled	23.1	23.1	4.0	4.0	0481/C04	0481/C04	0481/L10	0481/L10
112B-035	natural convection	i/p	i/p	i/p	i/p	i/p	i/p	i/p	i/p
	surface cooled	i/p	i/p	i/p	i/p	i/p	i/p	i/p	i/p
112B-058	natural convection	28.5	32.6	4.0	6.0	0481/C04	0481/C06	0481/L10	0481/L10
	surface cooled	42.8	42.8	10.0	10.0	0481/C10	0481/C10	0481/L10	0481/L10
112C-024	natural convection	18.6	22.0	2.5	2.5	0481/C03	0481/C03	0481/L10	0481/L10
	surface cooled	27.9	27.9	4.0	4.0	0481/C04	0481/C04	0481/L10	0481/L10
112C-035	natural convection	22.6	26.8	4.0	4.0	0481/C04	0481/C04	0481/L10	0481/L10
	surface cooled	33.9	33.9	6.0	6.0	0481/C06	0481/C06	0481/L10	0481/L10
112C-058	natural convection	37.7	44.6	6.0	10.0	0381/C06	0381/C10	0381/L35	0381/L35
	surface cooled	56.6	56.6	16.0	16.0	0381/C16	0381/C16	0381/L35	0381/L35

Continued on next page

Motor type	Cooling mode	Motor phase current $I_{Str(eff)}$ [A]		Cross section ¹⁾ power connection [mm ²]		Crimp INS...		Solder INS...	
		60K	100K	60K	100K	60K	100K	60K	100K
112D-027	natural convection	22.2	27.3	2.5	4.0	0481/C03	0481/C04	0481/L10	0481/L10
	surface cooled	33.3	33.3	6.0	6.0	0481/C06	0481/C06	0481/L10	0481/L10
115A-024	natural convection	14.4	i/p	6.0 ³⁾	i/p	0381/C06	i/p	0381/L35	i/p
	liquid cooled	27.4	27.4	6.0 ³⁾	6.0 ³⁾	0381/C06	0381/C06	0381/L35	0381/L35
115A-058	natural convection	24.3	i/p	6.0 ³⁾	i/p	0381/C06	i/p	0381/L35	i/p
	liquid cooled	46.2	46.2	10.0	10.0	0381/C10	0381/C10	0381/L35	0381/L35
115B-024	natural convection	22.0	i/p	6.0 ³⁾	i/p	0381/C06	i/p	0381/L35	i/p
	surface cooled	33.0	33.0	6.0 ³⁾	6.0 ³⁾	0381/C06	0381/C06	0381/L35	0381/L35
	liquid cooled	41.8	41.8	10.0	10.0	0381/C10	0381/C10	0381/L35	0381/L35
115B-058	natural convection	41.4	i/p	10.0	i/p	0381/C10	i/p	0381/L35	i/p
	surface cooled	62.1	62.1	16.0	16.0	0381/C16	0381/C16	0381/L35	0381/L35
	liquid cooled	78.7	78.7	25.0	25.0	0381/C25	0381/C25	0381/L35	0381/L35
115C-024	natural convection	31.6	i/p	6.0 ³⁾	i/p	0381/C06	i/p	0381/L35	i/p
	surface cooled	47.4	47.4	10.0	10.0	0381/C10	0381/C10	0381/L35	0381/L35
	liquid cooled	60.0	60.0	16.0	16.0	0381/C16	0381/C16	0381/L35	0381/L35
115C-058	natural convection	54.6	i/p	16.0	i/p	0381/C16	i/p	0381/L35	i/p
	surface cooled	81.9	81.9	25.0	25.0	0381/C25	0381/C25	0381/L35	0381/L35
	liquid cooled	103.7	103.7	35.0	35.0	0381/C35	0381/C35	0381/L35	0381/L35

Fig. 5-18: Motor overview when selecting motor power cables for an MHP

Parts for Making Power Cables of Third-Party Manufacturers

Note: Loss of guarantee! If third party cables are used, then the guarantee for the entire drive system is forfeited in terms of the resistance to interference (e.g., maintaining EMC requirements or similar). The use of Indramat cables is recommended !

Note: The user can make his own INDRAMAT cables. Information on doing so is outlined for

- tools and
 - mounting instructions
- in the document „Indramat connection technologies or making cables and appropriate tools“; DOK-CONNEX-CAB*INSTR02-MA01-EN-P.

Selecting power connectors ⇒ The following selection list specifies order numbers for the motor power connectors and cable cross sections needed.

Note: When selecting allow for the operating mode in which the motor is to be operated ($\Delta T60K$ or $\Delta T100K$).

- ⇒ Motor power connectors can either be crimped or soldered.
- ⇒ Suitable conduit threads must be mounted in the cables of the motor power cables used. Sections 7 through 13, “Dimensional data” outlines the relevant sizes.

Motor types	Connector size	Power strand cross section	Type supplement	
			Crimp	Solder
MHP041 MHP071 MHP090	0681	1,0 1,5 2,5	C03 C03 C03	--- --- ---
MHP093 MHP095 MHP112 ¹⁾	0481	1,5 2,5 4,0 6,0 10,0	C02 C03 C04 C06 ---	L10 L10 L10 L10 L10
MHP112C-058 MHP115	0381	6,0 10,0 16,0 25,0 35,0	C06 C10 C16 C25 C35	L35 L35 L35 L35 L35
Order numbers:	INS xxxx	/	xxx	<u>oder</u> xxx

1) All motor types except MHP112C-058

Fig. 5-19: Assignment power connector to motor types

Individual Feedback Connection Parts

Feedback connector ⇒ From the selection list below, select the suitable feedback connector.

Note: Use the feedback connector suited to INDRAMAT cable with plastic sheath and integral cable clamp for INDRAMAT cable INK0532. This feedback connector is best suited for making INDRAMAT cables and meet all EMC requirements.

Name	Feedback connector for INDRAMAT cable INK0532
	crimp version
straight connector	INS0379/C ¹⁾
angle connector	INS0664/C
1) Feedback connector with plastic sheathing	

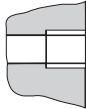
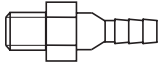

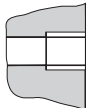
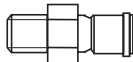
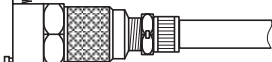

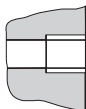
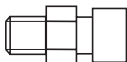

Fig. 5-20: Feedback connector

Note: The outgoing direction of angle connectors can be adapted to the conditions of the machine at the time of mounting. See section 13 „Feedback cable“ for details.

6 Coolant Connections

6.1 Type of Connections

The coolant connection of motors using a coolant can vary:

Connection	Pic.			
hose olive	Motor 	hose olive with winding R1/8" 	hose 	hose clip 
quick-coupling connection	Motor 	coupling with winding R1/8" 	coupling with clamp screw 	hose 
clamp type	Motor 	clamp with winding R1/8" 	hose 	

Y03MH81P.fh7

Fig. 6-1: Possible types of connections for coolants

The parts need for such connections are presently not available from Indramat. Instructions on selecting and sizing a heat dissipation unit are outlined in the following document: DOK-DIAX01-DRIVE***LIQ-AUS1-EN-P. It lists order information for the coolant connection accessories and names manufacturers and suppliers with addresses for cooling system components.

6.2 How to Connect

Coolant lines Coolant lines can be either

- pipe lines or
- hose systems.

Note: Due to the unavoidable corners that occur in pipeline systems (e.g., 90° bends) there are considerable pressure losses within the lines. This is why we recommend a hose system.

When selecting the coolant lines please allow for the pressure loss within the system. For greater lengths it is therefore advisable to have an inside line diameter of 9 mm, becoming narrower just before it reaches the connection point at the motor.

Coolant The coolant data specified in the document are for water.

Pressure loss The coolant flow through the drive components is subject to cross sectional and directional changes. This means that frictional and turning point losses occur. This losses take the form of a loss of pressure Δp .

Pressure loss Δp_n for liquid-cooled motors is specified in the technical data. It references the specified flow through amount of the coolant, water. If this flow through amount is calculated to a different temperature increase, then the loss of pressure is specified in the following curves.

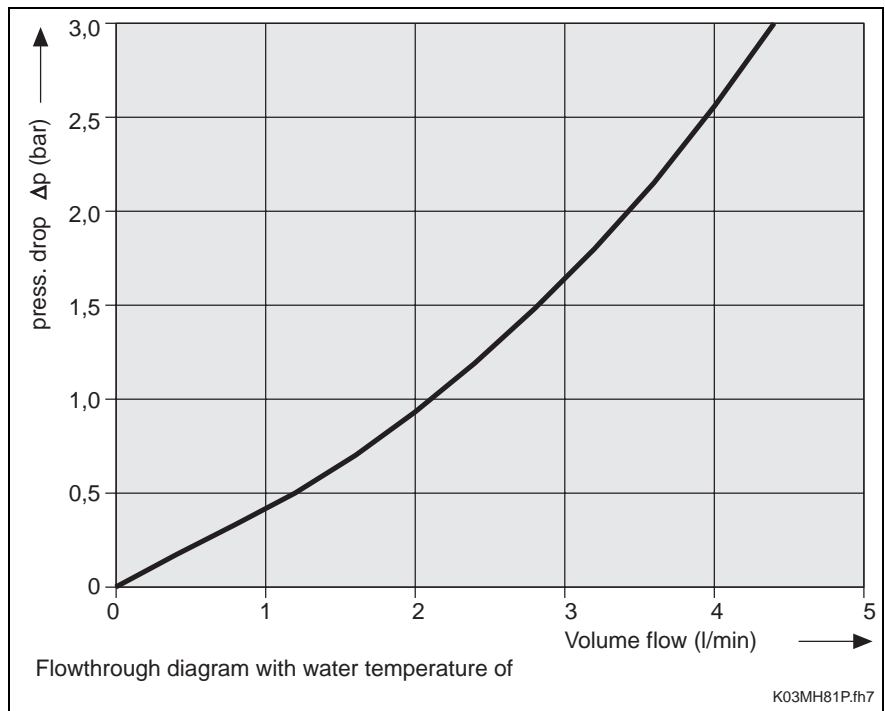

Fig. 6-2: Flow through diagram for MHP motors

Note: If a coolant other than water is used, then a different coolant-specific flow through diagram applies.

Supplementary documentation Supplementary information on additives or other coolants is specified in document "Liquid cooling of INDRAMAT drive components" (DOK-DIAX01-DRIVE***LIQ-AUS1-EN-P), part number 265 836.

7 MHP041

7.1 Technical data

Designations	Symbol	Unit	Data			
Motor type	MHP041A-144					
Motor overtemperature			$\Delta T_{60} \text{ K}^{1)}$	$\Delta T_{100} \text{ K}^{2)}$	$\Delta T_{60} \text{ K}^{1)}$ and $\Delta T_{100} \text{ K}^{2)}$	
Cooling type			natural convection	natural convection	surface cooled	liquid cooled
Characteristic motor speed	n_K	min^{-1}	7500		---	---
Continuous torque at standstill	M_0	Nm	1.3		---	---
Continuous current at standstill	$I_{0(\text{eff})}$	A	2.3		---	---
Rated motor power	P_N	kW	0.25		---	---
Base speed ³⁾	n_N	min^{-1}	5000		---	---
Nominal motor voltage	$U_{N(\text{eff})}$	V	198	in prep.	---	---
Nominal motor current	$I_{N(\text{eff})}$	A	0.8		---	---
Nominal motor torque	M_N	Nm	0.47		---	---
Thermal time constant	T_{th}	min	20		---	---
Theoretical maximum torque ⁴⁾	M_{max}	Nm	5.6			
Peak current	$I_{\text{max}(\text{eff})}$	A	10.4			
Rotor moment of inertia ⁵⁾	J_M	kgm^2	0.88×10^{-4}			
Torque constant at 20°C	K_{mE}	Nm/A	0.62			
Voltage constant at 20°C ⁶⁾	$K_{E\text{eff}}$	V/1000 min^{-1}	38.2			
Windings resistance at 20°C	R_{12}	Ω	7.0			
Windings inductance	L_{12}	mH	13.5			
Maximum speed	n_{max}	min^{-1}	7500			
Number of pole pairs	PZ		3			
Nominal frequency	f_N	Hz	250			
Data of equivalent circuit diagram						
Windings resistance	R_1	Ω	3.5			
Rotating field inductance	L_{1-D}	mH	6.75			
Speed measuring system data						
Number of lines	STR		2048			
Counting direction	DIRECT:	pos./neg.	+			
Mass ^{4) 10)}	m_M	kg	2.9			
Max. Motor temperature (Winding)	T_{max}	°C	155			
Allowed ambient temperature ⁷⁾	T_{um}	°C	0 to +40			
Allowed storage / transport temp.	T_L	°C	-20 to +80			
Max. Installation elevation ⁸⁾		m	1000 meters above sea level			
Protection category ⁹⁾			IP 65			
Insulation class			F (per DIN VDE 0530 Section 1)			
Housing coat			Black coat black (RAL 9005)			
1) Housing temperature 2) Winding temperature 3) Depends on torque needs of application. For standard applications, see n_{max} in selection lists of motor/controller combination. For other applications, use the usable speed achieved with required torque via the speed/torque curve. 4) Achievable maximum torque depends on drive controller. Only maximum torque M_{max} listed for a motor/controller combination is binding. 5) No holding brake 6) with 1000 min^{-1} . 7) With deviating ambient temperatures see section 4.1. 8) With deviating installation elevations see section 4.1. 9) with proper mounting of power and feedback cables. 10) No blower unit.						

Fig. 7-1: Technical data MHP041A-144

Designations		Symbol	Unit	Data			
Motor type		MHP041B-144					
Motor overtemperature			$\Delta T_{60} \text{ K}^{1)}$	$\Delta T_{100} \text{ K}^{2)}$	$\Delta T_{60} \text{ K}^{1)}$ and $\Delta T_{100} \text{ K}^{2)}$		
Cooling type			natural convection	natural convection	surface cooled	liquid cooled	
Characteristic motor speed	n_K	min^{-1}	6000		---	---	
Continuous torque at standstill	M_0	Nm	2.7		---	---	
Continuous current at standstill	$I_{0(\text{eff})}$	A	5.0		---	---	
Rated motor power	P_N	kW	0.27		---	---	
Base speed ³⁾	n_N	min^{-1}	4000		---	---	
Nominal motor voltage	$U_{N(\text{eff})}$	V	148	in prep.	---	---	
Nominal motor current	$I_{N(\text{eff})}$	A	1.9		---	---	
Nominal motor torque	M_N	Nm	0.64		---	---	
Thermal time constant	T_{th}	min	30		---	---	
Theoretical maximum torque ⁴⁾	M_{max}	Nm	11.3				
Peak current	$I_{\text{max}(\text{eff})}$	A	22.5				
Rotor moment of inertia ⁵⁾	J_M	kgm^2	1.7×10^{-4}				
Torque constant at 20°C	K_{mE}	Nm/A	0.59				
Voltage constant at 20°C ⁶⁾	$K_{E\text{eff}}$	$\text{V}/1000\text{min}^{-1}$	36.3				
Windings resistance at 20°C	R_{12}	Ω	1.8				
Windings inductance	L_{12}	mH	5.0				
Maximum speed	n_{max}	min^{-1}	7000				
Number of pole pairs	PZ		3				
Nominal frequency	f_N	Hz	200				
Data of equivalent circuit diagram							
	Windings resistance	R_1	Ω	0.9			
	Rotating field inductance	$L_1\text{-D}$	mH	2.5			
Speed measuring system data							
	Number of lines	STR	2048				
	Counting direction	DIRECT:	pos./neg.	+			
Mass ^{4) 10)}	m_M	kg	4.5				
Max. Motor temperature (Winding)	T_{max}	°C	155				
Allowed ambient temperature ⁷⁾	T_{um}	°C	0 to +40				
Allowed storage / transport temp.	T_L	°C	-20 to +80				
Max. Installation elevation ⁸⁾		m	1000 meters above sea level				
Protection category ⁹⁾			IP 65				
Insulation class			F (per DIN VDE 0530 Section 1)				
Housing coat			Black coat black (RAL 9005)				
1) Housing temperature 2) Winding temperature 3) Depends on torque needs of application. For standard applications, see n_{max} in selection lists of motor/controller combination. For other applications, use the usable speed achieved with required torque via the speed/torque curve. 4) Achievable maximum torque depends on drive controller. Only maximum torque M_{max} listed for a motor/controller combination is binding. 5) No holding brake 6) With 1000 min^{-1} . 7) With deviating ambient temperatures see section 4.1. 8) With deviating installation elevations see section 4.1. 9) with proper mounting of power and feedback cables. 10) No blower unit.							

Fig. 7-2: Technical data MHP041B-144

Designations	Symbol	Unit	Data holding brake
Motor type			MHP041B
Holding torque	M_H	Nm	2.2
Nominal voltage	U_N	V	DC 24 \pm 10%
Nominal current	I_N	A	0.4
Moment of inertia	J_B	kgm ²	0.16×10^{-4}
Link time	t_1	ms	19.0
Separating time	t_2	ms	28.0
Mass	m_B	kg	0.25

Fig. 7-3: Technical Data holding brake MHP041 (Option)

7.2 Torque/speed curves

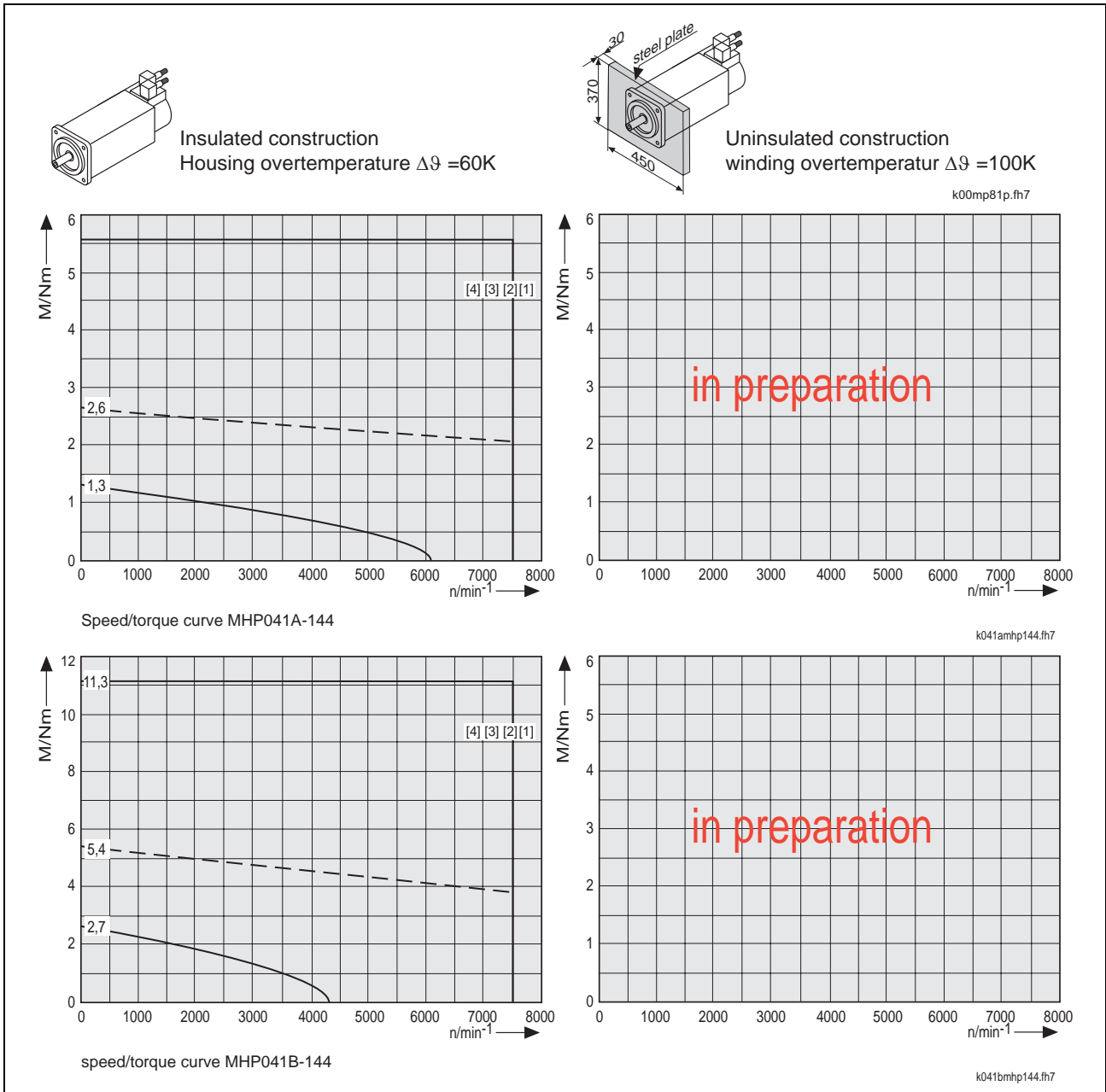

Fig. 7-4: Torque/speed curves MHP041

7.3 Maximum Shaft Load

Allowed maximum radial force F_{radial_max} and allowed radial force F_{radial} For details see section 4.6 „Shaft load“.

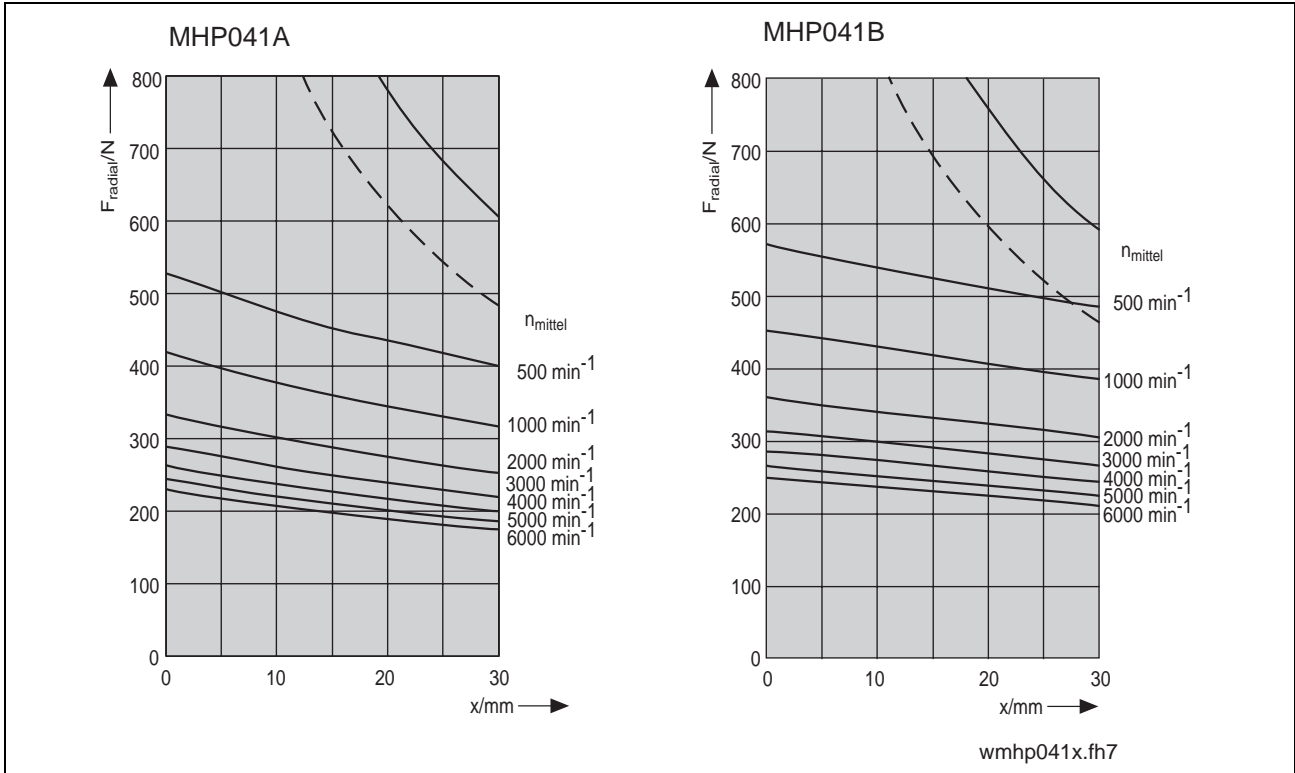

Fig. 7-5: MHD041: allowed maximum radial force F_{radial_max} and allowed radial force F_{radial}

Allowed axial force F_{axial}

$$F_{axial} = X \cdot F_{radial}$$

x: **0.49** for MHD041A
0.45 for MHD041B

F_{axial} : allowed axial force in N
 F_{radial} : allowed radial force in N

Fig. 7-6: MHD041: allowed axial force F_{axial}

7.4 Dimensional Data

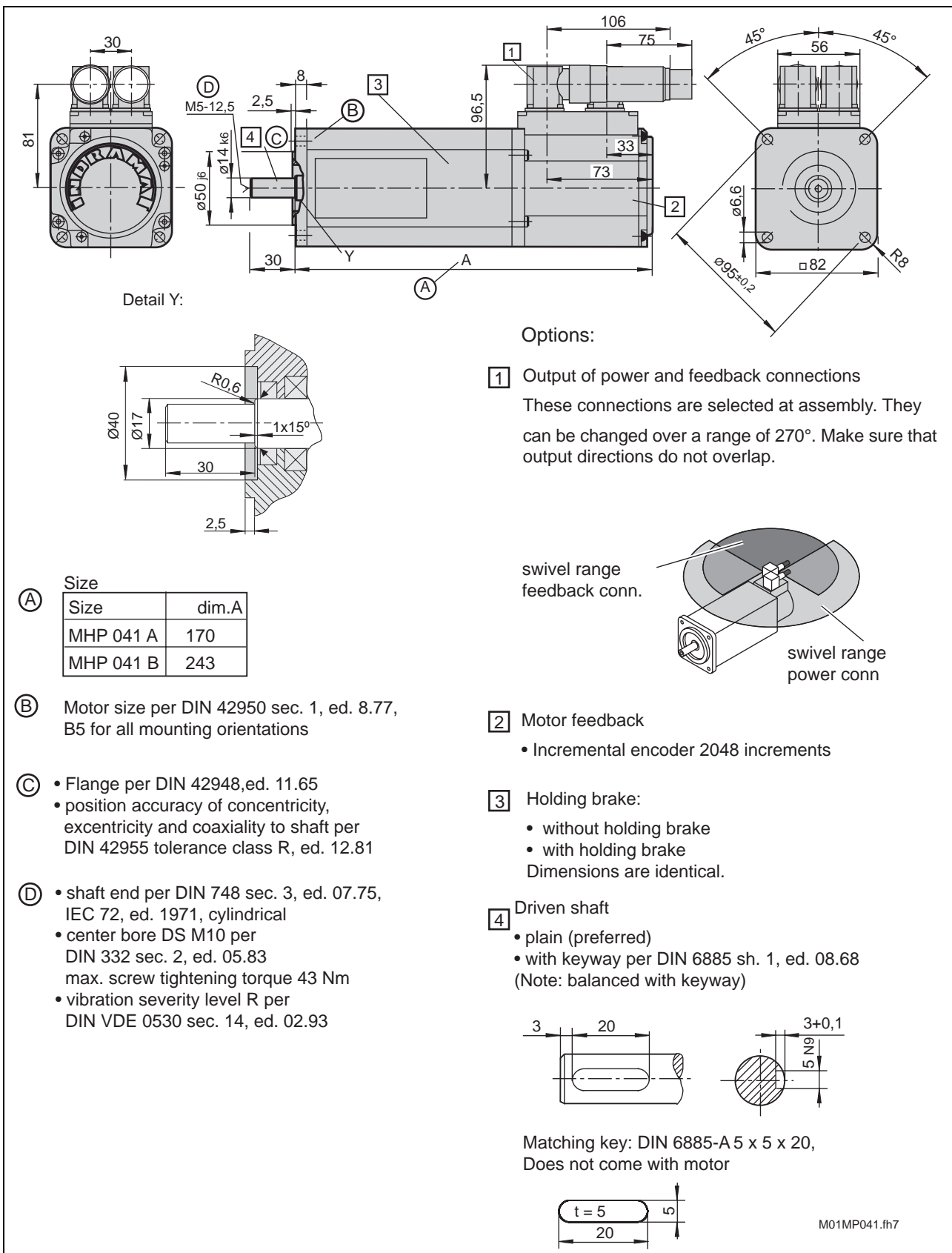

Fig. 7-7: Size sheet MHP041

7.5 Available Versions and Type Codes

Abbrev. Column →	1	2	3	4	5	6	7	8	9	0	1	2	3	4	5	6	7	8	9	0	1	2	3	4	5	6	7	8	9	0	1	2	3	4	5	6	7	8	9	0		
Example:	M	H	P	0	4	1	B	-	1	4	4	-	H	G	0	-	U	N	N	N	N	N	N	N	N	N	N	N	N	N	N	N	N	N	N	N	N	N	N	N	N	N

1. Product group

1.1 MHP. = MHP

2. Motor size

2.1 41 = 041

3. Motor length

3.1 Length. = A,B

4. Windings code

4.1 144 = 144

5. Motor feedback

5.1 Incremental encoder, 2.048 increments. = H

6. Driven shaft

6.1 plain shaft (with shaft sealing ring). = G

6.2 Shaft with key per DIN 6885-1 (with shaft sealing ring) = P

7. Holding brake

7.1 without holding brake = 0

7.2 with holding brake 2,2 Nm = 1

8. Output direction of power connection

8.1 Connector turnable 270° = U

9. Housing type ①

9.1 natural convection = N

10. Other design

10.1 none = NNNN

11. Standard reference

<u>Standard</u>	<u>Title</u>	<u>Edition</u>
DIN 6885-1	Drive Type Fastenings without Taper Action Parallel Keys, Keyways, Deep Patten	08.1968

Note:

① Housing "N" suited for natural convection and surface cooling

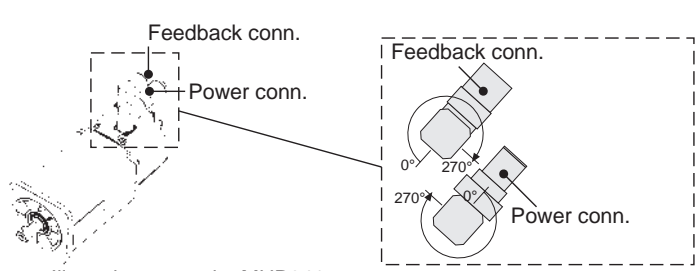

Feedback conn.

Power conn.

0°

270°

270°

0°

Power conn.

Illustration example: MHP041

t01mhp041.fh7

Fig. 7-8: Type codes MHP041

8 MHP071

8.1 Technical data

Designations	Symbol	Unit	Data			
Motor type	MHP071A-061					
Motor overtemperature			$\Delta T_{60} \text{ K}^{1)}$	$\Delta T_{100} \text{ K}^{2)}$	$\Delta T_{60} \text{ K}^{1)}$ and $\Delta T_{100} \text{ K}^{2)}$	
Cooling type			natural convection	natural convection	surface cooled	liquid cooled
Characteristic motor speed	n_K	min^{-1}	4500		---	---
Continuous torque at standstill	M_0	Nm	3.5		---	---
Continuous current at standstill	$I_{0(\text{eff})}$	A	3.4		---	---
Rated motor power	P_N	kW	0.8		---	---
Base speed ³⁾	n_N	min^{-1}	4500		---	---
Nominal motor voltage	$U_{N(\text{eff})}$	V	324	in prep.	---	---
Nominal motor current	$I_{N(\text{eff})}$	A	1.7		---	---
Nominal motor torque	M_N	Nm	1.75		---	---
Thermal time constant	T_{th}	min	45		---	---
Theoretical maximum torque ⁴⁾	M_{max}	Nm	14.0			
Peak current	$I_{\text{max}(\text{eff})}$	A	15.3			
Rotor moment of inertia ⁵⁾	J_M	kgm^2	4.4×10^{-4}			
Torque constant at 20°C	K_{mE}	Nm/A	1.12			
Voltage constant at 20°C ⁶⁾	$K_{E\text{eff}}$	V/1000 min^{-1}	69.1			
Windings resistance at 20°C	R_{12}	Ω	5.2			
Windings inductance	L_{12}	mH	16.0			
Maximum speed	n_{max}	min^{-1}	6000			
Number of pole pairs	PZ		4			
Nominal frequency	f_N	Hz	300			
Data of equivalent circuit diagram						
Windings resistance	R_1	Ω	2.6			
Rotating field inductance	L_{1-D}	mH	8.0			
Speed measuring system data						
Number of lines	STR		2048			
Counting direction	DIRECT:	pos./neg.	+			
Mass ^{4) 10)}	m_M	kg	6.0			
Max. Motor temperature (Winding)	T_{max}	°C	155			
Allowed ambient temperature ⁷⁾	T_{um}	°C	0 to +40			
Allowed storage / transport temp.	T_L	°C	-20 to +80			
Max. Installation elevation ⁸⁾		m	1000 meters above sea level			
Protection category ⁹⁾			IP 65			
Insulation class			F (per DIN VDE 0530 section 1)			
Housing coat			Prime coat black (RAL 9005)			
1) Housing temperature 2) Winding temperature 3) Depends on torque needs of application. For standard applications, see n_{max} in selection lists of motor/controller combination. For other applications, use the usable speed achieved with required torque via the speed/torque curve. 4) Achievable maximum torque depends on drive controller. Only maximum torque M_{max} listed for a motor/controller combination is binding. 5) No holding brake 6) with 1000 min^{-1} . 7) With deviating ambient temperatures see section 4.1. 8) With deviating installation elevations see section 4.1. 9) with proper mounting of power and feedback cables. 10) No blower unit..						

Fig. 8-1: Technical data MHP071A-061

Designations		Symbol	Unit	Data		
Motor type		MHP071B-035				
Motor overtemperature				$\Delta T_{60} \text{ K}^{1)}$	$\Delta T_{100} \text{ K}^{2)}$	$\Delta T_{60} \text{ K}^{1)}$ and $\Delta T_{100} \text{ K}^{2)}$
Cooling type				natural convection	natural convection	surface cooled liquid cooled
Characteristic motor speed	n_K	min^{-1}	2500		2500	---
Continuous torque at standstill	M_0	Nm	8.0		12.0	---
Continuous current at standstill	$I_{0(\text{eff})}$	A	4.3		6.5	---
Rated motor power	P_N	kW	1.4		2.7	---
Base speed ³⁾	n_N	min^{-1}	2500		2500	---
Nominal motor voltage	$U_{N(\text{eff})}$	V	334	in prep.	364	---
Nominal motor current	$I_{N(\text{eff})}$	A	2.8		5.5	---
Nominal motor torque	M_N	Nm	5.2		10.2	---
Thermal time constant	T_{th}	min	45		20	---
Theoretical maximum torque ⁴⁾	M_{max}	Nm	32.0			
Peak current	$I_{\text{max}(\text{eff})}$	A	19.4			
Rotor moment of inertia ⁵⁾	J_M	kgm^2	8.7×10^{-4}			
Torque constant at 20°C	K_{mE}	Nm/A	2.04			
Voltage constant at 20°C ⁶⁾	$K_{E\text{eff}}$	V/1000min ⁻¹	125.5			
Windings resistance at 20°C	R_{12}	Ω	4.6			
Windings inductance	L_{12}	mH	23.0			
Maximum speed	n_{max}	min^{-1}	6000			
Number of pole pairs	PZ		4			
Nominal frequency	f_N	Hz	167			
Data of equivalent circuit diagram						
	Windings resistance	R_1	Ω	2.3		
	Rotating field inductance	L_{1-D}	mH	11.5		
Speed measuring system data						
	Number of lines	STR	2048			
	Counting direction	DIRECT:	pos./neg.	+		
Mass ^{4) 10)}	m_M	kg	8.8			
Max. Motor temperature (Winding)	T_{max}	°C	155			
Allowed ambient temperature ⁷⁾	T_{um}	°C	0 to +40			
Allowed storage / transport temp.	T_L	°C	-20 to +80			
Max. Installation elevation ⁸⁾		m	1000 meters above sea level			
Protection category ⁹⁾			IP 65			
Insulation class			F (per DIN VDE 0530 section 1)			
Housing coat			Prime coat black (RAL 9005)			
<p>1) Housing temperature</p> <p>2) Winding temperature</p> <p>3) Depends on torque needs of application. For standard applications, see n_{max} in selection lists of motor/controller combination. For other applications, use the usable speed achieved with required torque via the speed/torque curve.</p> <p>4) Achievable maximum torque depends on drive controller. Only maximum torque M_{max} listed for a motor/controller combination is binding.</p> <p>5) No holding brake</p> <p>6) with 1000 min⁻¹.</p> <p>7) With deviating ambient temperatures see section 4.1 .</p> <p>8) With deviating installation elevations see section 4.1 .</p> <p>9) with proper mounting of power and feedback cables.</p> <p>10) No blower unit.</p>						

Fig. 8-2: Technical data MHP071B-035

Designations		Symbol	Unit	Data				
Motor type		MHP071B-061						
Motor overtemperature				$\Delta T_{60} \text{ K}^{1)}$	$\Delta T_{100} \text{ K}^{2)}$	$\Delta T_{60} \text{ K}^{1)}$ and $\Delta T_{100} \text{ K}^{2)}$		
Cooling type				natural convection	natural convection	surface cooled	liquid cooled	
Characteristic motor speed	n_K	min^{-1}	4500	4500	4500	---		
Continuous torque at standstill	M_0	Nm	8.0	9.0	12.0	---		
Continuous current at standstill	$I_{0(\text{eff})}$	A	7.7	8.9	11.6	---		
Rated motor power	P_N	kW	1.2	2.1	2.9	---		
Base speed ³⁾	n_N	min^{-1}	3000	3000	3000	---		
Nominal motor voltage	$U_{N(\text{eff})}$	V	218	228	237	---		
Nominal motor current	$I_{N(\text{eff})}$	A	3.6	6.7	9.0	---		
Nominal motor torque	M_N	Nm	3.7	6.8	9.3	---		
Thermal time constant	T_{th}	min	45	45	20	---		
Theoretical maximum torque ⁴⁾	M_{max}	Nm	32.0					
Peak current	$I_{\text{max}(\text{eff})}$	A	34.7					
Rotor moment of inertia ⁵⁾	J_M	kgm^2	8.7×10^{-4}					
Torque constant at 20°C	K_{mE}	Nm/A	1.14					
Voltage constant at 20°C ⁶⁾	$K_{E\text{eff}}$	$\text{V}/1000\text{min}^{-1}$	70.0					
Windings resistance at 20°C	R_{12}	Ω	1.45					
Windings inductance	L_{12}	mH	7.2					
Maximum speed	n_{max}	min^{-1}	6000					
Number of pole pairs	PZ		4					
Nominal frequency	f_N	Hz	200					
Data of equivalent circuit diagram								
	Windings resistance	R_1	Ω	0.73				
	Rotating field inductance	L_{1-D}	mH	3.6				
Speed measuring system data								
	Number of lines	STR	2048					
	Counting direction	DIRECT:	pos./neg.	+				
Mass ^{4) 10)}	m_M	kg	8.8					
Max. Motor temperature (Winding)	T_{max}	$^{\circ}\text{C}$	155					
Allowed ambient temperature ⁷⁾	T_{um}	$^{\circ}\text{C}$	0 to +40					
Allowed storage / transport temp.	T_L	$^{\circ}\text{C}$	-20 to +80					
Max. Installation elevation ⁸⁾		m	1000 meters above sea level					
Protection category ⁹⁾			IP 65					
Insulation class			F (per DIN VDE 0530 section 1)					
Housing coat			Prime coat black (RAL 9005)					
<p>1) Housing temperature</p> <p>2) Winding temperature</p> <p>3) Depends on torque needs of application. For standard applications, see n_{max} in selection lists of motor/controller combination. For other applications, use the usable speed achieved with required torque via the speed/torque curve.</p> <p>4) Achievable maximum torque depends on drive controller. Only maximum torque M_{max} listed for a motor/controller combination is binding.</p> <p>5) No holding brake</p> <p>6) with 1000 min^{-1}.</p> <p>7) With deviating ambient temperatures see section 4.1.</p> <p>8) With deviating installation elevations see section 4.1.</p> <p>9) with proper mounting of power and feedback cables.</p> <p>10) No blower unit.</p>								

Fig. 8-3: Technical data MHP071B-061

Designations	Symbol	Unit	Data holding brake
Motor type			MHP071B
Holding torque	M_H	Nm	5.0
Nominal voltage	U_N	V	DC 24 $\pm 10\%$
Nominal current	I_N	A	0.56
Moment of inertia	J_B	kgm ²	0.72×10^{-4}
Link time	t_1	ms	20
Separating time	t_2	ms	38
Mass	m_B	kg	0.6

Fig. 8-4: Technical data holding brake MHP071 (Option)

Designations	Symbol	Unit	Data surface cooling	
Nominal voltage	U_N	V	1 x AC 230 $\pm 10\%$	1 x AC 115 $\pm 10\%$
Nominal current	I_N	A	0.1	0.2
Power consumption	S_N	VA	18	17
Frequency	f	Hz	50	60

Fig. 8-5: Technical data surface cooling MHP071 (Option)

8.2 Torque/speed curves

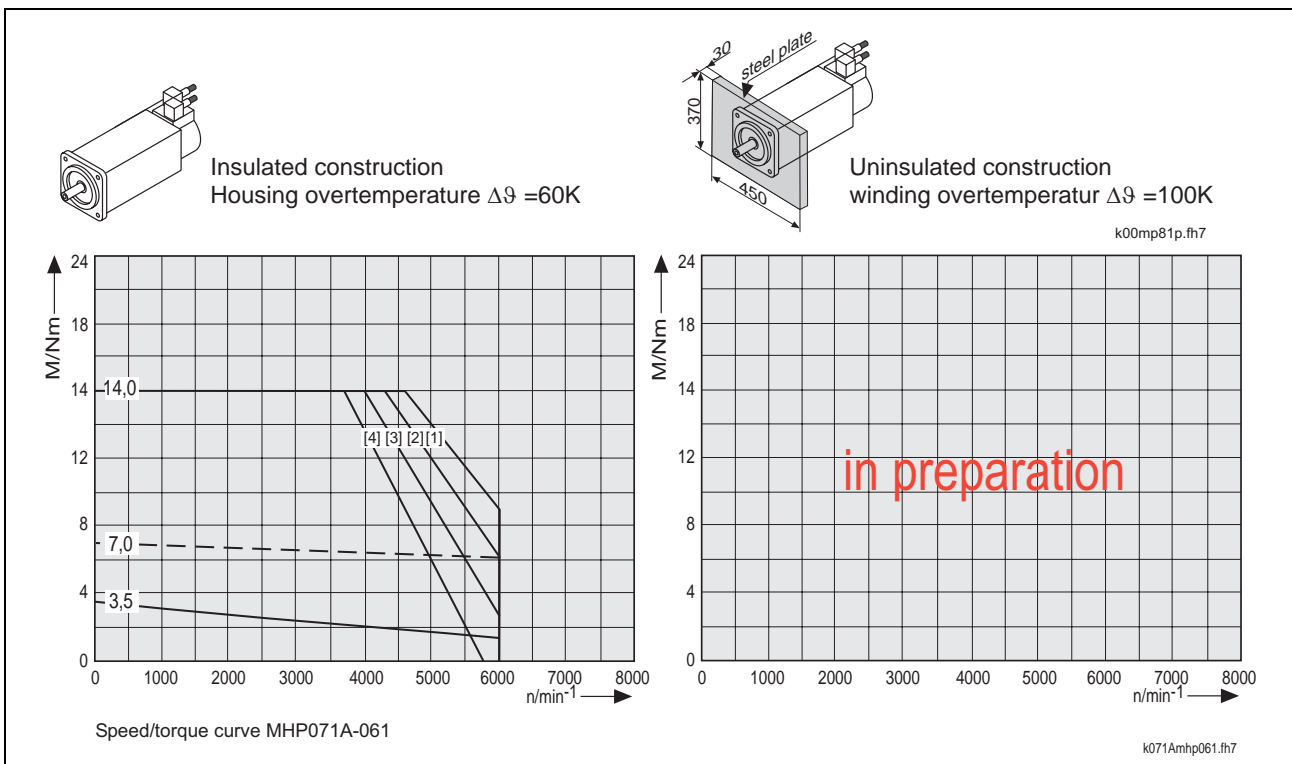
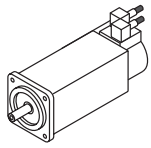
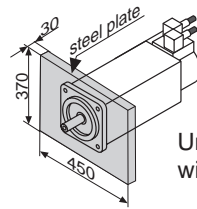

Fig. 8-6: Torque/speed curves MHP071A



Insulated construction
Housing overtemperature $\Delta\theta = 60\text{K}$



Uninsulated construction
winding overtemperature $\Delta\theta = 100\text{K}$

k00mp81p.fh7

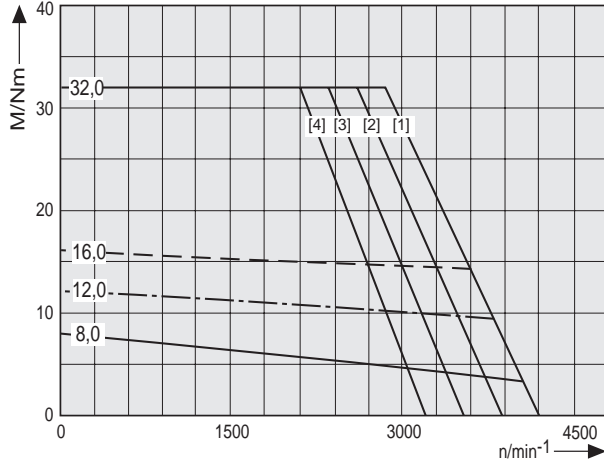

Speed/torque curve MHP071B-035

k071Bmhp035.fh7

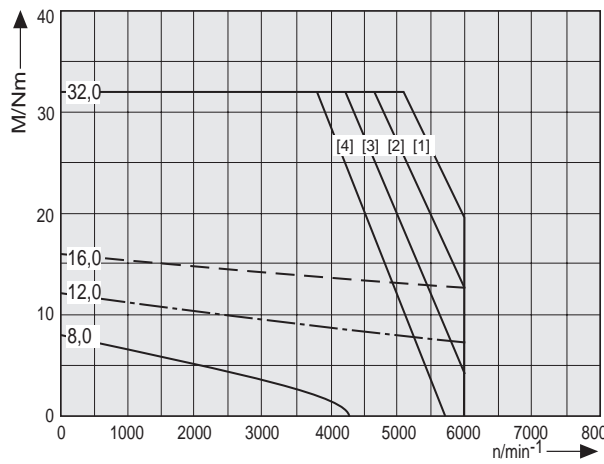
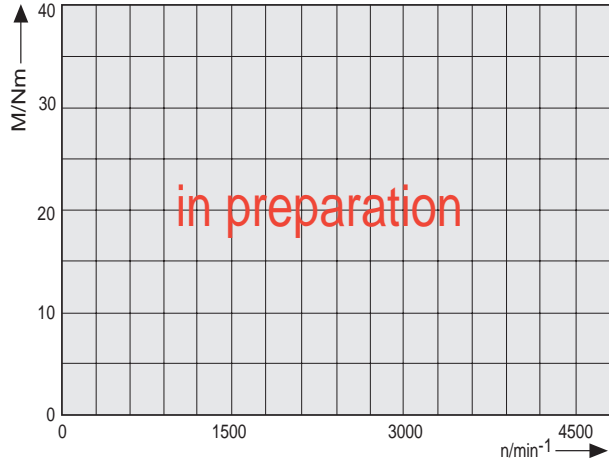

Speed/torque curve MHP071B-061

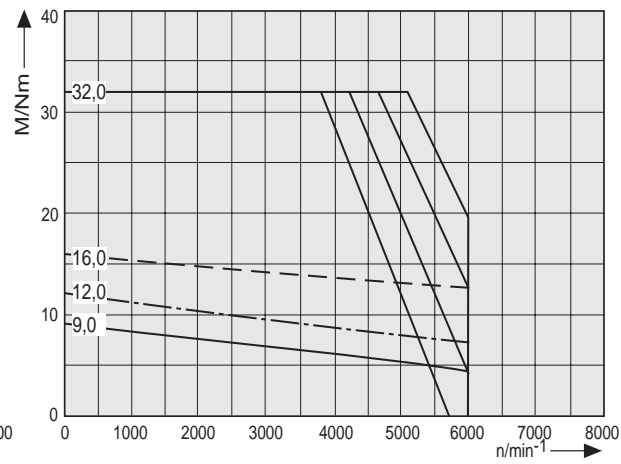

k071bmq061.fh7

Fig. 8-7: Torque/speed curves MHP071B

8.3 Maximum Shaft Load

Allowed maximum radial force $F_{\text{radial_max}}$ and allowed radial force F_{radial} For details see section 4.6 „Shaft load“.

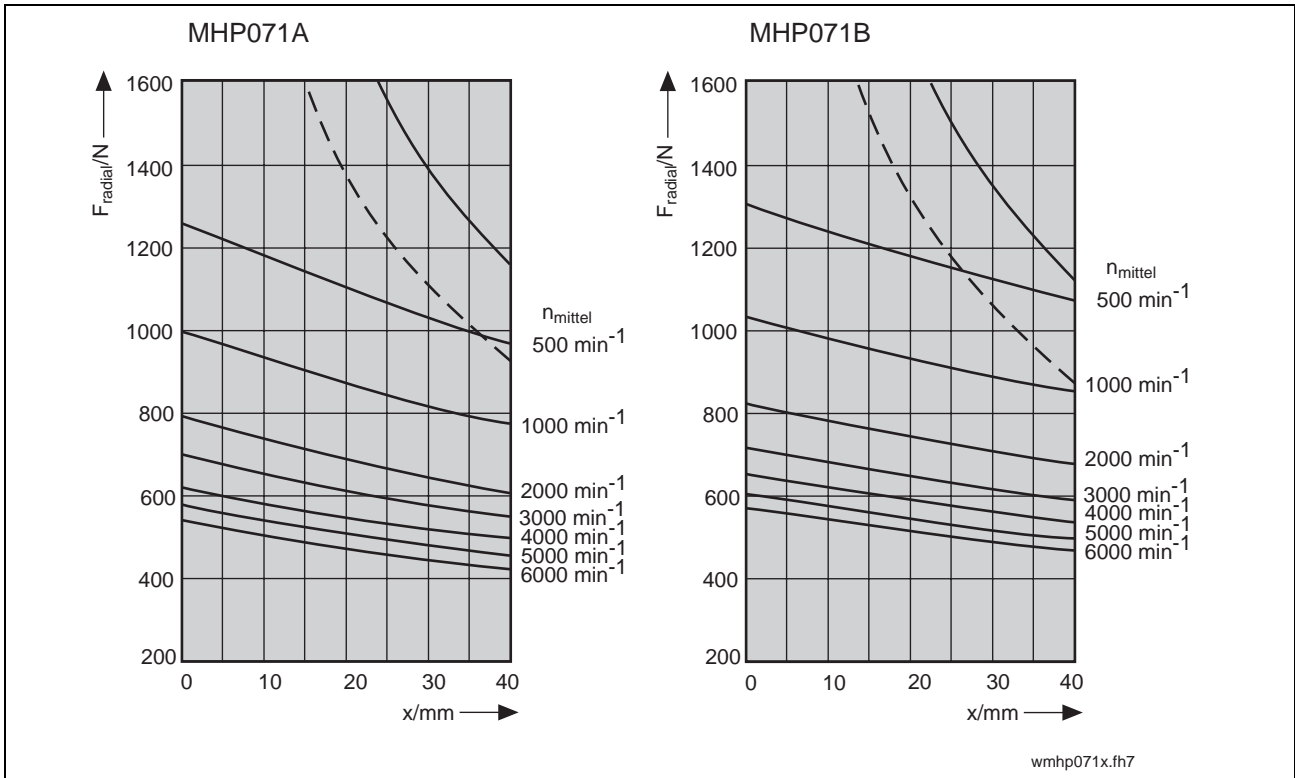

Fig. 8-8: MHP071: allowed maximum radial force $F_{\text{radial_max}}$ and allowed radial force F_{radial}

Allowed axial force F_{axial}

$$F_{\text{axial}} = X \cdot F_{\text{radial}}$$

X : = **0.58** for MHP071A
 = **0.55** for MHP071B

F_{axial} : allowed axial force in N

F_{radial} : allowed radial force in N

Fig. 8-9: MHP071: allowed axial force F_{axial}

8.4 Dimensional data

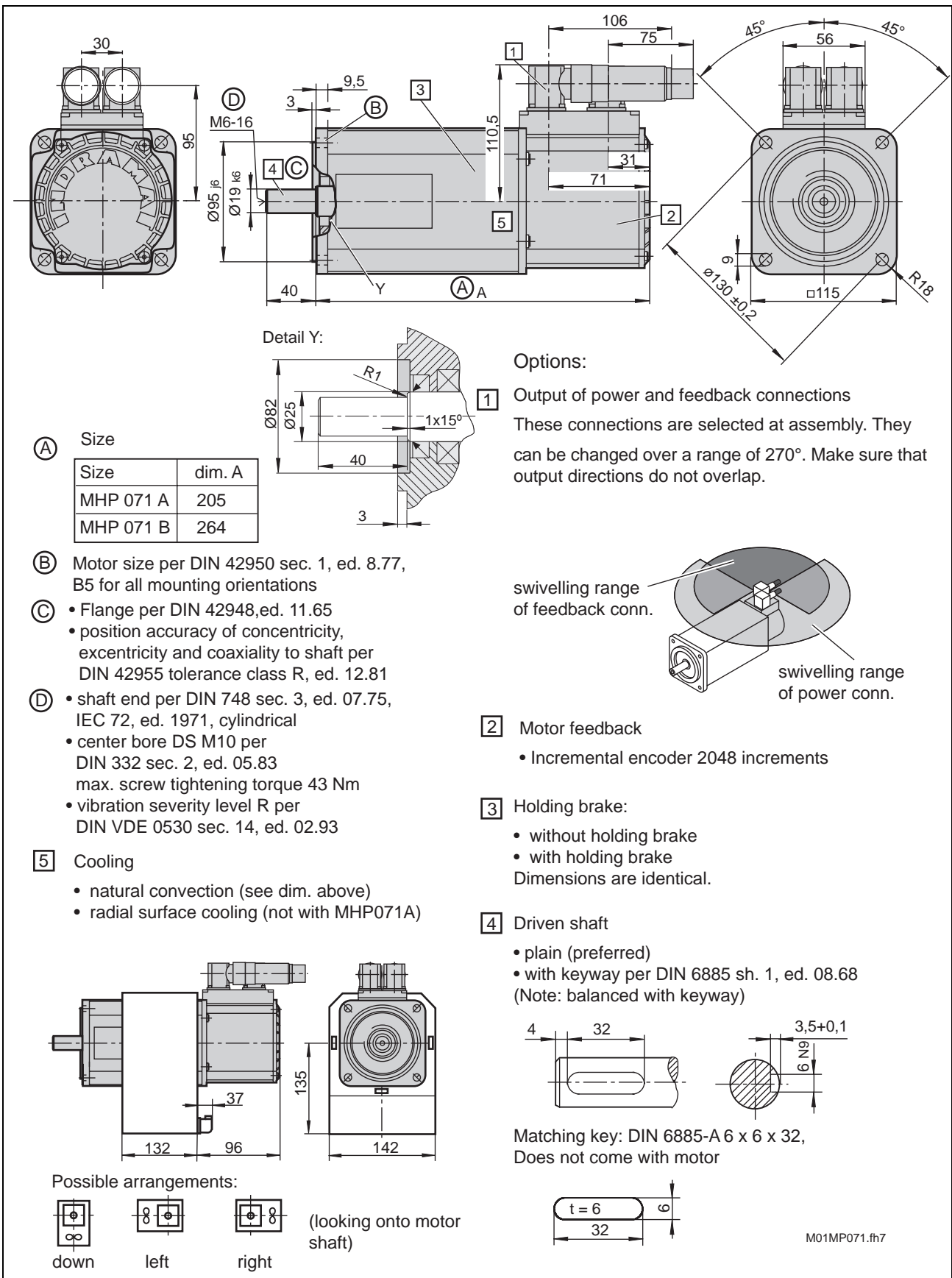

Fig. 8-10: Size sheet MHP071

8.6 Blower Units

Selecting the blower unit

Select the blower unit wanted from the table below.

Motor type	Order designation of blower unit	
	AC 115V / 60Hz	AC 230V / 50Hz
MHP071A	---	---
MHP071B	LEMD-RB071B2XX	LEMD-RB071B1XX
--- mounting of blower unit not possible		

Fig. 8-12: Blower unit MHP071

Motor with mounted blower unit

To obtain a motor with mounted surface cooling the type code of the radial blower unit is listed as a subitem of the MHP motor with the blower position and arrangement specified.

Order position	Designation
1	1 pc. digital AC motor MHP071B-035-NG0-BN
1.1	1 pc. blower unit LEMD-RB071B2XX mounted to item 1, blower on left

Fig. 8-13: Order information for MHP motor with mounted blower unit

Motor with separate blower unit

If the blower unit is listed as an order item by itself, then it will be delivered separate of the motor, i.e., not mounted.

Order position	Designation
1	1 pc. digital AC motor MHP071B-035-NG0-BN
2	1 pc. blower unit LEMD-RB071B2XX

Fig. 8-14: Order information for MHP motor with separate blower unit

9 MHP090

9.1 Technical Data

Designations	Symbol	Unit	Data			
Motor type	MHP090B-035					
Motor overtemperature			$\Delta T_{60} \text{ K}^{1)}$	$\Delta T_{100} \text{ K}^{2)}$	$\Delta T_{60} \text{ K}^{1)}$ and $\Delta T_{100} \text{ K}^{2)}$	
Cooling type			natural convection	natural convection	surface cooled	liquid cooled
Characteristic motor speed	n_K	min^{-1}	2500	2500	2500	---
Continuous torque at standstill	M_0	Nm	12.0	13.5	18.0	---
Continuous current at standstill	$I_{0(\text{eff})}$	A	7.7	9.0	11.6	---
Rated motor power	P_N	kW	2.2	3.2	4.6	---
Base speed ³⁾	n_N	min^{-1}	3000	3000	3000	---
Nominal motor voltage	$U_{N(\text{eff})}$	V	350	363	383	---
Nominal motor current	$I_{N(\text{eff})}$	A	4.6	6.8	9.5	---
Nominal motor torque	M_N	Nm	7.2	10.2	14.7	---
Thermal time constant	T_{th}	min	60	60	30	---
Theoretical maximum torque ⁴⁾	M_{max}	Nm	43.5			
Peak current	$I_{max(\text{eff})}$	A	34.7			
Rotor moment of inertia ⁵⁾	J_M	kgm^2	43.0×10^{-4}			
Torque constant at 20°C	K_{mE}	Nm/A	1.80			
Voltage constant at 20°C ⁶⁾	$K_{E\text{eff}}$	V/1000 min^{-1}	111.0			
Windings resistance at 20°C	R_{12}	Ω	1.88			
Windings inductance	L_{12}	mH	13.0			
Maximum speed	n_{max}	min^{-1}	5000			
Number of pole pairs	PZ		4			
Nominal frequency	f_N	Hz	200			
Data of equivalent circuit diagram						
	Windings resistance	R_1	Ω	0.94		
	Rotating field inductance	L_{1-D}	mH	7.75		
Speed measuring system data						
	Number of lines	STR	2048			
	Counting direction	DIRECT:	pos./neg.	+		
Mass ^{4) 10)}	m_M	kg	6.0			
Max. Motor temperature (Winding)	T_{max}	°C	155			
Allowed ambient temperature ⁷⁾	T_{um}	°C	0 to +40			
Allowed storage / transport temp.	T_L	°C	-20 to +80			
Max. Installation elevation ⁸⁾		m	1000 meters above sea level			
Protection category ⁹⁾			IP 65			
Insulation class			F (per DIN VDE 0530 Section 1)			
Housing coat			Prime coat black (RAL 9005)			
1) Housing temperature 2) Winding temperature 3) Depends on torque needs of application. For standard applications, see n_{max} in selection lists of motor/controller combination. For other applications, use the usable speed achieved with required torque via the speed/torque curve. 4) Achievable maximum torque depends on drive controller. Only maximum torque M_{max} listed for a motor/controller combination is binding. 5) No holding brake 6) with 1000 min^{-1} . 7) With deviating ambient temperatures see section 4.1. 8) With deviating installation elevations see section 4.1. 9) with proper mounting of power and feedback cables. 10) No blower unit.						

Fig. 9-1: Technical Data MHP090B-035

Designations		Symbol	Unit	Data		
Motor type		MHP090B-058				
Motor overtemperature				$\Delta T_{60} \text{ K}^{1)}$	$\Delta T_{100} \text{ K}^{2)}$	$\Delta T_{60} \text{ K}^{1)}$ and $\Delta T_{100} \text{ K}^{2)}$
Cooling type				natural convection	natural convection	surface cooled liquid cooled
Characteristic motor speed	n_K	min^{-1}	4000		4000	---
Continuous torque at standstill	M_0	Nm	12.0		18.0	---
Continuous current at standstill	$I_{0(\text{eff})}$	A	12.3		18.5	---
Rated motor power	P_N	kW	1.8		5.6	---
Base speed ³⁾	n_N	min^{-1}	4000		4000	---
Nominal motor voltage	$U_{N(\text{eff})}$	V	286	in prep.	320	---
Nominal motor current	$I_{N(\text{eff})}$	A	4.3		13.8	---
Nominal motor torque	M_N	Nm	4.2		13.4	---
Thermal time constant	T_{th}	min	60		30	---
Theoretical maximum torque ⁴⁾	M_{max}	Nm	43.5			
Peak current	$I_{\text{max}(\text{eff})}$	A	55.4			
Rotor moment of inertia ⁵⁾	J_M	kgm^2	43.0×10^{-4}			
Torque constant at 20°C	K_{mE}	Nm/A	1.13			
Voltage constant at 20°C ⁶⁾	$K_{E\text{eff}}$	$\text{V}/1000\text{min}^{-1}$	70.0			
Windings resistance at 20°C	R_{12}	Ω	0.74			
Windings inductance	L_{12}	mH	5.8			
Maximum speed	n_{max}	min^{-1}	5000			
Number of pole pairs	PZ		4			
Nominal frequency	f_N	Hz	267			
Data of equivalent circuit diagram						
	Windings resistance	R_1	Ω	0.37		
	Rotating field inductance	L_{1-D}	mH	2.9		
Speed measuring system data						
	Number of lines	STR	2048			
	Counting direction	DIRECT:	pos./neg.	+		
Mass ^{4) 10)}	m_M	kg	14.0			
Max. Motor temperature (Winding)	T_{max}	$^{\circ}\text{C}$	155			
Allowed ambient temperature ⁷⁾	T_{um}	$^{\circ}\text{C}$	0 to +40			
Allowed storage / transport temp.	T_L	$^{\circ}\text{C}$	-20 to +80			
Max. Installation elevation ⁸⁾		m	1000 meters above sea level			
Protection category ⁹⁾			IP 65			
Insulation class			F (per DIN VDE 0530 Section 1)			
Housing coat			Prime coat black (RAL 9005)			
<p>1) Housing temperature 2) Winding temperature 3) Depends on torque needs of application. For standard applications, see n_{max} in selection lists of motor/controller combination. For other applications, use the usable speed achieved with required torque via the speed/torque curve. 4) Achievable maximum torque depends on drive controller. Only maximum torque M_{max} listed for a motor/controller combination is binding. 5) No holding brake 6) with 1000 min^{-1}. 7) With deviating ambient temperatures see section 4.1. 8) With deviating installation elevations see section 4.1. 9) with proper mounting of power and feedback cables. 10) No blower unit.</p>						

Fig. 9-2: Technical Data MHP090B-058

Designations	Symbol	Unit	Data holding brake
Motor type			MHP090B
Holding torque	M_H	Nm	11
Nominal voltage	U_N	V	DC 24 $\pm 10\%$
Nominal current	I_N	A	0.71
Moment of inertia	J_B	kgm ²	3.6×10^{-4}
Link time	t_2	ms	13
Separating time	t_1	ms	30
Mass	m_B	kg	1.1

Fig. 9-3: Technical data holding brake MHP090 (Option)

Designation	Symbol	Unit	Data Surface cooling	
Nominal voltage	U_N	V	1 x AC 230 $\pm 10\%$	1 x AC 115 $\pm 10\%$
Nominal current	I_N	A	0.2	0.4
Power consumption	S_N	VA	40	39
Frequency	f	Hz	50	60

Fig. 9-4: Technical data surface cooling MHP090 (Option)

9.2 Torque/speed curves

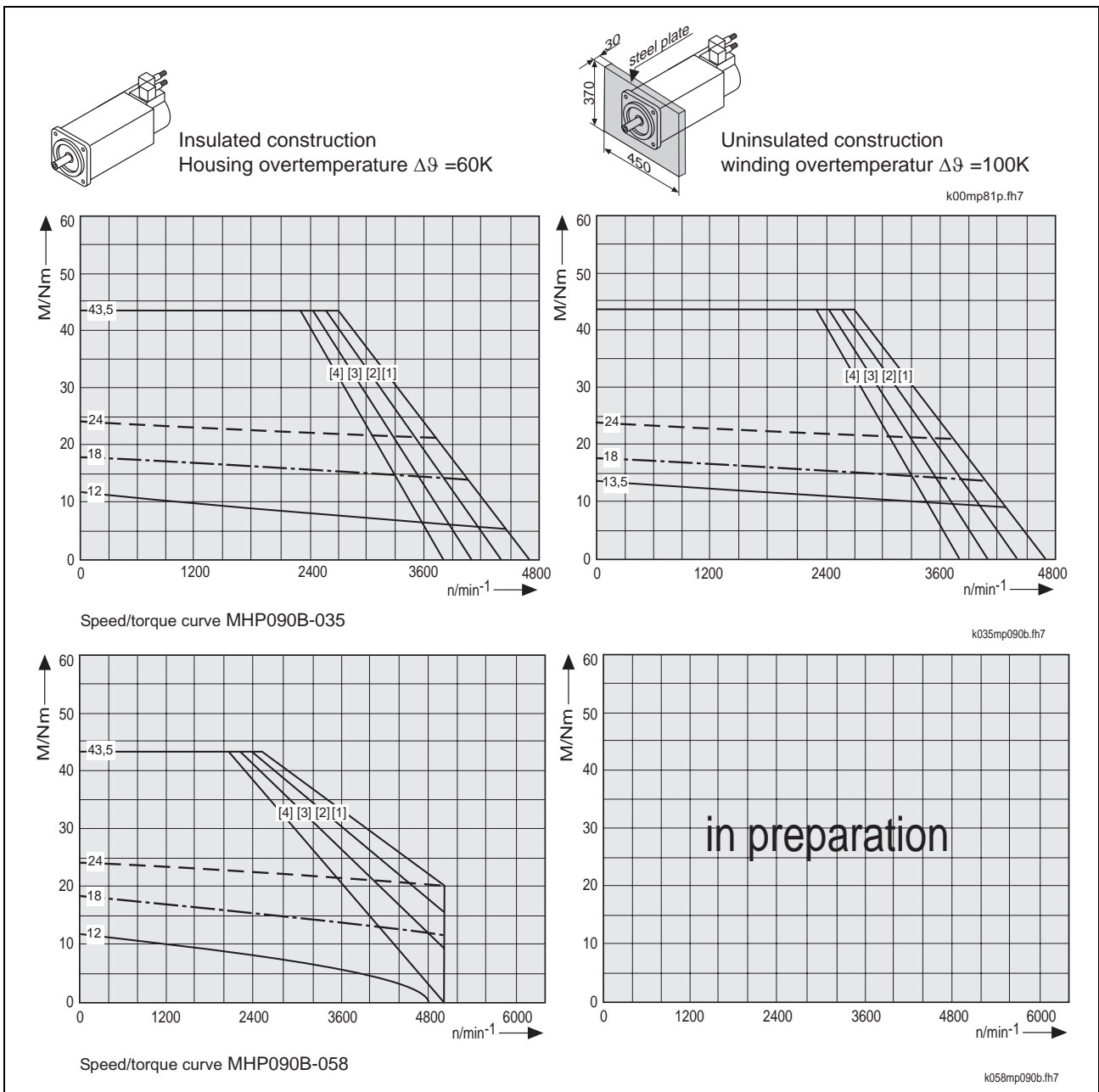

Fig. 9-5: Torque/speed curves

9.3 Maximum Shaft Load

For details see section 4.6 „ Shaft load “.

Allowed maximum radial force $F_{\text{radial_max}}$ and allowed radial force F_{radial}

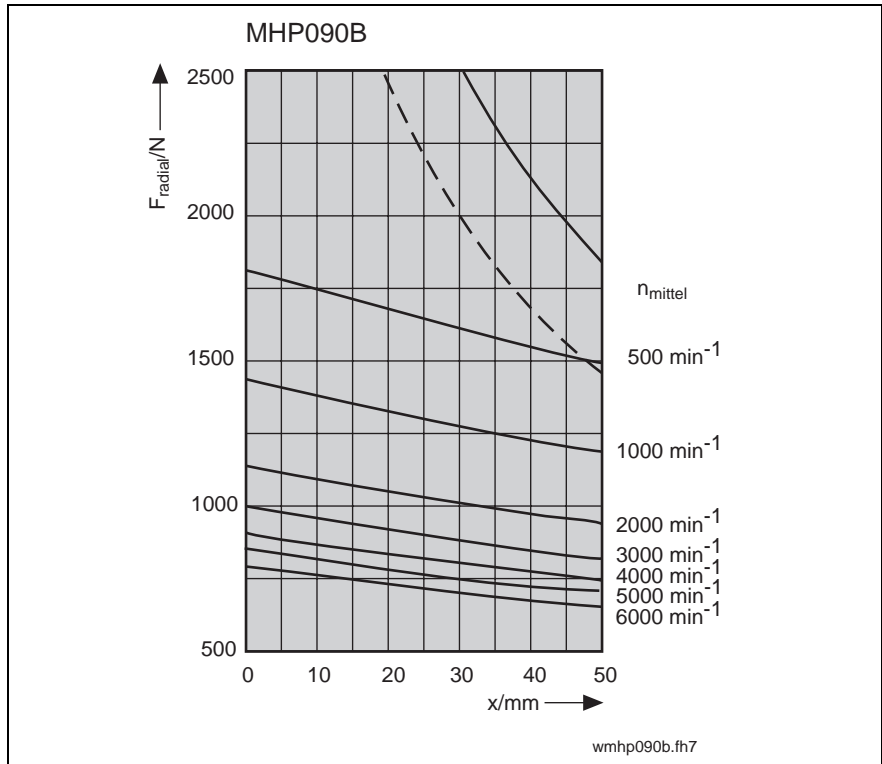

Fig. 9-6: MHP090: allowed maximum radial force $F_{\text{radial_max}}$ and allowed radial force F_{radial}

Allowed axial force F_{axial}

$$F_{\text{axial}} = 0,34 \cdot F_{\text{radial}}$$

F_{axial} : allowed axial force in N
 F_{radial} : allowed radial force in N

Fig. 9-7: MHP090: allowed axial force F_{axial}

9.4 Dimensional data

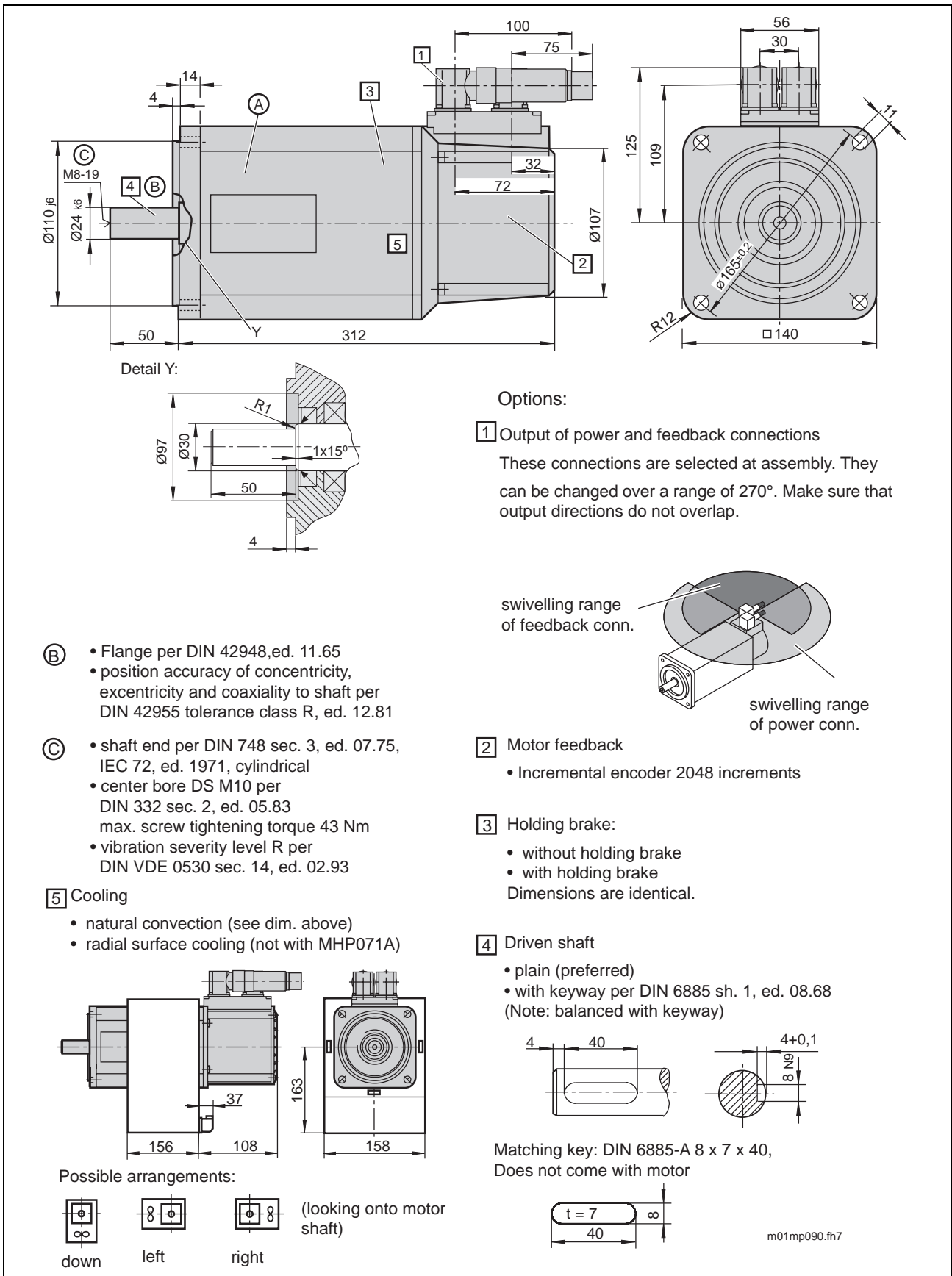

Fig. 9-8: Size sheet MHP090

9.5 Available Versions and type codes

Abbrev.	Column	1	2	3	4	5	6	7	8	9	0	1	2	3	4	5	6	7	8	9	0	1	2	3	4	5	6	7	8	9	0	1	2	3	4	5	6	7	8	9	0						
Example:		M	H	P	0	9	0	B	-	0	3	5	-	H	G	0	-	U	N	N	N	N	N	N	N	N	N	N	N	N	N	N	N	N	N	N	N	N	N	N	N	N	N	N	N	N	N

- 1. Product group
- 1.1 MHP..... = MHP

- 2. Motor size
- 2.1 90..... = 090

- 3. Motor length
- 3.1 Length = B

- 4. Windings code
- 4.1 024..... = 024
- 4.2 035..... = 035
- 4.3 058..... = 058

- 5. Motor feedback
- 5.2 Incremental encoder, 2.048 increments. = H

- 6. Driven shaft
- 6.1 plain shaft (with shaft sealing ring). = G
- 6.2 Shaft with key per DIN 6885-Page 1
(with shaft sealing ring) = P

- 7. Holding brake
- 7.1 without holding brake = 0
- 7.2 with holding brake 11,0 Nm = 1

- 8. Output direction of power connection
- 8.1 Connector turnable 270° = U

- 9. Housing type ①
- 9.1 for natural convection = N

- 10. Other design
- 10.1 none = NNNN

- 11. Standard reference

<u>Standard</u>	<u>Designation</u>	<u>Edition</u>
DIN 6885-Page 1	Drive Type Fastenings without Taper Action Parallel Keys, Keyways, Deep Patten	1968 August

Note:

① Housing type "N" for natural convection and surface cooling

t01mhp090.fh7

Fig. 9-9: Type codes MHP090

9.6 Blower Units

Selecting the blower unit

Select blower unit from table below.

Motor type	Order designation for blower unit	
	AC 115V / 60Hz	AC 230V / 50Hz
MHP090B	LEMH-RB090B2XX	LEMH-RB090B1XX

Fig. 9-10: Blower unit MHP093

Motor with mounted blower unit

To obtain a motor with mounted surface cooling list the radial blower unit as a subitem of the MHP motor noting the blower arrangement wanted.

Order position	Designation
1	1 pc. digital AC motor MHP090B-035-NG0-BN
1.1	1 pc. blower unit LEMH-RB090B2XX mounted to Pos. 1 blower on left

Fig. 9-11: Order information for MHP motor with mounted blower unit

Motor with separate blower unit

If the blower unit is listed on the order as a separate item, then it will be delivered separate of the motor, i.e., not mounted.

Order position	Designation
1	1 pc. digital AC motor MHP090B-035-NG0-BN
2	1 pc. blower unit LEMH-RB090B2XX

Fig. 9-12: Order information for MHP motor with separate blower unit

10 MHP093

10.1 Technical data

Designation	Symbol	Unit	Data			
Motor type	MHP093A-024					
Motor overtemperature			$\Delta T_{60} \text{ K}^{1)}$	$\Delta T_{100} \text{ K}^{2)}$	$\Delta T_{60} \text{ K}^{1)}$ and $\Delta T_{100} \text{ K}^{2)}$	
Cooling type			natural convection	natural convection	surface cooled	liquid cooled
Characteristic motor speed	n_K	min^{-1}	2000		---	---
Continuous torque at standstill	M_0	Nm	12.0		---	---
Continuous current at standstill	$I_{0(\text{eff})}$	A	5.3		---	---
Rated motor power	P_N	kW	1.7		---	---
Base speed ³⁾	n_N	min^{-1}	2000		---	---
Nominal motor voltage	$U_{N(\text{eff})}$	V	324	in prep.	---	---
Nominal motor current	$I_{N(\text{eff})}$	A	3.7		---	---
Nominal motor torque	M_N	Nm	8.3		---	---
Thermal time constant	T_{th}	min	40		---	---
Theoretical maximum torque ⁴⁾	M_{max}	Nm	44.0			
Peak current	$I_{\text{max}(\text{eff})}$	A	23.9			
Rotor moment of inertia ⁵⁾	J_M	kgm^2	17.3×10^{-4}			
Torque constant at 20°C	K_{mE}	Nm/A	2.5			
Voltage constant at 20°C ⁶⁾	$K_{E\text{eff}}$	$\text{V}/1000\text{min}^{-1}$	154.0			
Windings resistance at 20°C	R_{12}	Ω	2.95			
Windings inductance	L_{12}	mH	19.3			
Maximum speed	n_{max}	min^{-1}	6000			
Number of pole pairs	PZ		4			
Nominal frequency	f_N	Hz	133			
Data of equivalent circuit diagram						
winding resistance	R_1	Ω	2.95			
Rotary field inductance	L_{1-D}	mH	19.3			
Speed measuring system data						
Number of lines	STR		2048			
Counting direction	DIRECT:	pos./neg.	+			
Mass ^{4) 10)}	m_M	kg	14.5			
Max. Motor temperature (Winding)	T_{max}	°C	155			
Allowed ambient temperature ⁷⁾	T_{um}	°C	0 to +40			
Allowed storage / transport temp.	T_L	°C	-20 to +80			
Max. Installation elevation ⁸⁾		m	1000 meters above sea level			
Protection category ⁹⁾			IP 65			
Insulation class			F (per DIN VDE 0530 section 1)			
Housing coat			prime coat black (RAL 9005)			
1) Housing temperature 2) Winding temperature 3) Depends on torque needs of application. For standard applications, see n_{max} in selection lists of motor/controller combination. For other applications, use the usable speed achieved with required torque via the speed/torque curve. 4) Achievable maximum torque depends on drive controller. Only maximum torque M_{max} listed for a motor/controller combination is binding. 5) No holding brake 6) with 1000 min^{-1} . 7) With deviating ambient temperatures see section 4.1. 8) With deviating installation elevations see section 4.1. 9) with proper mounting of power and feedback cables. 10) No blower unit.						

Fig. 10-1: Technical data MHP093A-024

Designation		Symbol	Unit	Data		
Motor type		MHP093A-035				
Motor overtemperature				$\Delta T_{60} \text{ K}^{1)}$	$\Delta T_{100} \text{ K}^{2)}$	$\Delta T_{60} \text{ K}^{1)}$ and $\Delta T_{100} \text{ K}^{2)}$
Cooling type				natural convection	natural convection	surface cooled liquid cooled
Characteristic motor speed	n_K	min^{-1}	3000		---	---
Continuous torque at standstill	M_0	Nm	12.0		---	---
Continuous current at standstill	$I_{0(\text{eff})}$	A	7.3		---	---
Rated motor power	P_N	kW	1.9		---	---
Base speed ³⁾	n_N	min^{-1}	3000		---	---
Nominal motor voltage	$U_{N(\text{eff})}$	V	347	in prep.	---	---
Nominal motor current	$I_{N(\text{eff})}$	A	3.7		---	---
Nominal motor torque	M_N	Nm	6.0		---	---
Thermal time constant	T_{th}	min	40		---	---
Theoretical maximum torque ⁴⁾	M_{max}	Nm			44.0	
Peak current	$I_{\text{max}(\text{eff})}$	A			32.9	
Rotor moment of inertia ⁵⁾	J_M	kgm^2			17.3×10^{-4}	
Torque constant at 20°C	K_{mE}	Nm/A			1.82	
Voltage constant at 20°C ⁶⁾	$K_{E\text{eff}}$	$\text{V}/1000\text{min}^{-1}$			112.2	
Windings resistance at 20°C	R_{12}	Ω			1.75	
Windings inductance	L_{12}	mH		10.8		
Maximum speed	n_{max}	min^{-1}		6000		
Number of pole pairs	PZ			4		
Nominal frequency	f_N	Hz		200		
Data of equivalent circuit diagram						
	winding resistance	R_1	Ω		0.86	
	Rotary field inductance	L_{1-D}	mH		5.4	
Speed measuring system data						
	Number of lines	STR			2048	
	Counting direction	DIRECT:	pos./neg.		+	
Mass ^{4) 10)}	m_M	kg			14.5	
Max. Motor temperature (Winding)	T_{max}	$^{\circ}\text{C}$			155	
Allowed ambient temperature ⁷⁾	T_{um}	$^{\circ}\text{C}$			0 to +40	
Allowed storage / transport temp.	T_L	$^{\circ}\text{C}$			-20 to +80	
Max. Installation elevation ⁸⁾		m			1000 meters above sea level	
Protection category ⁹⁾					IP 65	
Insulation class					F (per DIN VDE 0530 section 1)	
Housing coat					prime coat black (RAL 9005)	
<p>1) Housing temperature</p> <p>2) Winding temperature</p> <p>3) Depends on torque needs of application. For standard applications, see n_{max} in selection lists of motor/controller combination. For other applications, use the usable speed achieved with required torque via the speed/torque curve.</p> <p>4) Achievable maximum torque depends on drive controller. Only maximum torque M_{max} listed for a motor/controller combination is binding.</p> <p>5) No holding brake</p> <p>6) with 1000 min^{-1}.</p> <p>7) With deviating ambient temperatures see section 4.1.</p> <p>8) With deviating installation elevations see section 4.1.</p> <p>9) with proper mounting of power and feedback cables.</p> <p>10) No blower unit.</p>						

Fig. 10-2: Technical data MHP093A-035

Designation		Symbol	Unit	Data		
Motor type		MHP093A-058				
Motor overtemperature				$\Delta T_{60} \text{ K}^{1)}$	$\Delta T_{100} \text{ K}^{2)}$	$\Delta T_{60} \text{ K}^{1)}$ and $\Delta T_{100} \text{ K}^{2)}$
Cooling type				natural convection	natural convection	surface cooled liquid cooled
Characteristic motor speed	n_K	min^{-1}	4000		---	---
Continuous torque at standstill	M_0	Nm	12.0		---	---
Continuous current at standstill	$I_{0(\text{eff})}$	A	8.9		---	---
Rated motor power	P_N	kW	1.3		---	---
Base speed ³⁾	n_N	min^{-1}	4000		---	---
Nominal motor voltage	$U_{N(\text{eff})}$	V	369	in prep.	---	---
Nominal motor current	$I_{N(\text{eff})}$	A	2.23		---	---
Nominal motor torque	M_N	Nm	3.0		---	---
Thermal time constant	T_{th}	min	40		---	---
Theoretical maximum torque ⁴⁾	M_{max}	Nm			44.0	
Peak current	$I_{\text{max}(\text{eff})}$	A			40.1	
Rotor moment of inertia ⁵⁾	J_M	kgm^2			17.3×10^{-4}	
Torque constant at 20°C	K_{mE}	Nm/A			1.48	
Voltage constant at 20°C ⁶⁾	$K_{E\text{eff}}$	$\text{V}/1000\text{min}^{-1}$			91.3	
Windings resistance at 20°C	R_{12}	Ω			1.09	
Windings inductance	L_{12}	mH			6.9	
Maximum speed	n_{max}	min^{-1}			6000	
Number of pole pairs	PZ				4	
Nominal frequency	f_N	Hz			267	
Data of equivalent circuit diagram						
	winding resistance	R_1	Ω		0.55	
	Rotary field inductance	L_{1-D}	mH		3.45	
Speed measuring system data						
	Number of lines	STR			2048	
	Counting direction	DIRECT:	pos./neg.		+	
Mass ^{4) 10)}	m_M	kg			14.5	
Max. Motor temperature (Winding)	T_{max}	$^{\circ}\text{C}$			155	
Allowed ambient temperature ⁷⁾	T_{um}	$^{\circ}\text{C}$			0 to +40	
Allowed storage / transport temp.	T_L	$^{\circ}\text{C}$			-20 to +80	
Max. Installation elevation ⁸⁾		m			1000 meters above sea level	
Protection category ⁹⁾					IP 65	
Insulation class					F (per DIN VDE 0530 section 1)	
Housing coat					prime coat black (RAL 9005)	
1) Housing temperature 2) Winding temperature 3) Depends on torque needs of application. For standard applications, see n_{max} in selection lists of motor/controller combination. For other applications, use the usable speed achieved with required torque via the speed/torque curve. 4) Achievable maximum torque depends on drive controller. Only maximum torque M_{max} listed for a motor/controller combination is binding. 5) No holding brake 6) with 1000 min^{-1} . 7) With deviating ambient temperatures see section 4.1. 8) With deviating installation elevations see section 4.1. 9) with proper mounting of power and feedback cables. 10) No blower unit.						

Fig. 10-3: Technical data MHP093A-058

Designation		Symbol	Unit	Data			
Motor type		MHP093B-035					
Motor overtemperature				$\Delta T_{60} \text{ K}^{1)}$	$\Delta T_{100} \text{ K}^{2)}$	$\Delta T_{60} \text{ K}^{1)}$ and $\Delta T_{100} \text{ K}^{2)}$	
Cooling type				natural convection	natural convection	surface cooled	liquid cooled
Characteristic motor speed	n_K	min^{-1}	2500	2500	2500	2500	
Continuous torque at standstill	M_0	Nm	17.5	20	26.3	33.3	
Continuous current at standstill	$I_{0(\text{eff})}$	A	8.8	10.3	13.2	16.7	
Rated motor power	P_N	kW	2.3	3.8	5.4	7.7	
Base speed ³⁾	n_N	min^{-1}	2500	2500	2500	2500	
Nominal motor voltage	$U_{N(\text{eff})}$	V	349	359	372	395	
Nominal motor current	$I_{N(\text{eff})}$	A	4.4	7.5	10.4	14.8	
Nominal motor torque	M_N	Nm	8.8	14.5	20.8	29.5	
Thermal time constant	T_{th}	min	60	60	30	20	
Theoretical maximum torque ⁴⁾	M_{max}	Nm	66.0				
Peak current	$I_{\text{max}(\text{eff})}$	A	39.6				
Rotor moment of inertia ⁵⁾	J_M	kgm^2	25.0×10^{-4}				
Torque constant at 20°C	K_{mE}	Nm/A	2.2				
Voltage constant at 20°C ⁶⁾	$K_{E\text{eff}}$	V/1000min ⁻¹	136.0				
Windings resistance at 20°C	R_{12}	Ω	1.26				
Windings inductance	L_{12}	mH	10.7				
Maximum speed	n_{max}	min^{-1}	6000				
Number of pole pairs	PZ		4				
Nominal frequency	f_N	Hz	167				
Data of equivalent circuit diagram							
	winding resistance	R_1	Ω	0.63			
	Rotary field inductance	L_{1-D}	mH	5.35			
Speed measuring system data							
	Number of lines	STR	2048				
	Counting direction	DIRECT:	pos./neg.	+			
Mass ^{4) 10)}	m_M	kg	19.0				
Max. Motor temperature (Winding)	T_{max}	°C	155				
Allowed ambient temperature ⁷⁾	T_{um}	°C	0 to +40				
Allowed storage / transport temp.	T_L	°C	-20 to +80				
Max. Installation elevation ⁸⁾		m	1000 meters above sea level				
Protection category ⁹⁾			IP 65				
Insulation class			F (per DIN VDE 0530 section 1)				
Housing coat			prime coat black (RAL 9005)				
<p>1) Housing temperature</p> <p>2) Winding temperature</p> <p>3) Depends on torque needs of application. For standard applications, see n_{max} in selection lists of motor/controller combination. For other applications, use the usable speed achieved with required torque via the speed/torque curve.</p> <p>4) Achievable maximum torque depends on drive controller. Only maximum torque M_{max} listed for a motor/controller combination is binding.</p> <p>5) No holding brake</p> <p>6) with 1000 min⁻¹.</p> <p>7) With deviating ambient temperatures see section 4.1.</p> <p>8) With deviating installation elevations see section 4.1.</p> <p>9) with proper mounting of power and feedback cables.</p> <p>10) No blower unit.</p>							

Fig. 10-4: Technical data MHP093B-035

Designation		Symbol	Unit	Data			
Motor type		MHP093B-058					
Motor overtemperature				$\Delta T_{60} \text{ K}^{1)}$	$\Delta T_{100} \text{ K}^{2)}$	$\Delta T_{60} \text{ K}^{1)}$ and $\Delta T_{100} \text{ K}^{2)}$	
Cooling type				natural convection	natural convection	surface cooled	liquid cooled
Characteristic motor speed	n_K	min^{-1}	4000	4000	4000	4000	
Continuous torque at standstill	M_0	Nm	17.5	21.0	26.3	33.3	
Continuous current at standstill	$I_{0(\text{eff})}$	A	15.0	18.5	22.5	28.5	
Rated motor power	P_N	kW	1.8	2.8	4.3	6.5	
Base speed ³⁾	n_N	min^{-1}	2000	2000	2000	2000	
Nominal motor voltage	$U_{N(\text{eff})}$	V	162	167	172	184	
Nominal motor current	$I_{N(\text{eff})}$	A	7.3	12.4	17.6	26.3	
Nominal motor torque	M_N	Nm	8.5	13.4	20.6	30.8	
Thermal time constant	T_{th}	min	60	60	30	20	
Theoretical maximum torque ⁴⁾	M_{max}	Nm	66.0				
Peak current	$I_{max(\text{eff})}$	A	67.5				
Rotor moment of inertia ⁵⁾	J_M	kgm^2	25.0×10^{-4}				
Torque constant at 20°C	K_{mE}	Nm/A	1.28				
Voltage constant at 20°C ⁶⁾	$K_{E\text{eff}}$	V/1000min ⁻¹	79.0				
Windings resistance at 20°C	R_{12}	Ω	0.44				
Windings inductance	L_{12}	mH	3.2				
Maximum speed	n_{max}	min^{-1}	6000				
Number of pole pairs	PZ		4				
Nominal frequency	f_N	Hz	133				
Data of equivalent circuit diagram							
	winding resistance	R_1	Ω	0.22			
	Rotary field inductance	L_{1-D}	mH	1.6			
Speed measuring system data							
	Number of lines	STR	2048				
	Counting direction	DIRECT:	pos./neg.	+			
Mass ^{4) 10)}	m_M	kg	19.0				
Max. Motor temperature (Winding)	T_{max}	°C	155				
Allowed ambient temperature ⁷⁾	T_{um}	°C	0 to +40				
Allowed storage / transport temp.	T_L	°C	-20 to +80				
Max. Installation elevation ⁸⁾		m	1000 meters above sea level				
Protection category ⁹⁾			IP 65				
Insulation class			F (per DIN VDE 0530 section 1)				
Housing coat			prime coat black (RAL 9005)				
<p>1) Housing temperature</p> <p>2) Winding temperature</p> <p>3) Depends on torque needs of application. For standard applications, see n_{max} in selection lists of motor/controller combination. For other applications, use the usable speed achieved with required torque via the speed/torque curve.</p> <p>4) Achievable maximum torque depends on drive controller. Only maximum torque M_{max} listed for a motor/controller combination is binding.</p> <p>5) No holding brake</p> <p>6) with 1000 min⁻¹.</p> <p>7) With deviating ambient temperatures see section 4.1.</p> <p>8) With deviating installation elevations see section 4.1.</p> <p>9) with proper mounting of power and feedback cables.</p> <p>10) No blower unit.</p>							

Fig. 10-5: Technical data MHP093B-058

Designation		Symbol	Unit	Data			
Motor type		MHP093C-035					
Motor overtemperature				$\Delta T_{60} \text{ K}^{1)}$	$\Delta T_{100} \text{ K}^{2)}$	$\Delta T_{60} \text{ K}^{1)}$ and $\Delta T_{100} \text{ K}^{2)}$	
Cooling type				natural convection	natural convection	surface cooled	liquid cooled
Characteristic motor speed	n_K	min^{-1}	2500	2500	2500	2500	
Continuous torque at standstill	M_0	Nm	23.0	28.0	34.5	43.7	
Continuous current at standstill	$I_{0(\text{eff})}$	A	12.4	15.5	18.6	23.6	
Rated motor power	P_N	kW	2.4	4.7	6.8	10.4	
Base speed ³⁾	n_N	min^{-1}	2500	2500	2500	2500	
Nominal motor voltage	$U_{N(\text{eff})}$	V	320	329	339	360	
Nominal motor current	$I_{N(\text{eff})}$	A	4.9	9.9	14.0	21.5	
Nominal motor torque	M_N	Nm	9.0	17.9	26.1	39.8	
Thermal time constant	T_{th}	min	75	75	35	25	
Theoretical maximum torque ⁴⁾	M_{max}	Nm	88.0				
Peak current	$I_{\text{max}(\text{eff})}$	A	55.8				
Rotor moment of inertia ⁵⁾	J_M	kgm^2	30.0×10^{-4}				
Torque constant at 20°C	K_{mE}	Nm/A	2.04				
Voltage constant at 20°C ⁶⁾	$K_{E\text{eff}}$	$\text{V}/1000\text{min}^{-1}$	126.0				
Windings resistance at 20°C	R_{12}	Ω	0.79				
Windings inductance	L_{12}	mH	6.2				
Maximum speed	n_{max}	min^{-1}	6000				
Number of pole pairs	PZ		4				
Nominal frequency	f_N	Hz	166				
Data of equivalent circuit diagram							
	winding resistance	R_1	Ω	0.4			
	Rotary field inductance	L_{1-D}	mH	3.1			
Speed measuring system data							
	Number of lines	STR	2048				
	Counting direction	DIRECT: pos./neg.	+				
Mass ^{4) 10)}	m_M	kg	23.5				
Max. Motor temperature (Winding)	T_{max}	°C	155				
Allowed ambient temperature ⁷⁾	T_{um}	°C	0 to +40				
Allowed storage / transport temp.	T_L	°C	-20 to +80				
Max. Installation elevation ⁸⁾		m	1000 meters above sea level				
Protection category ⁹⁾			IP 65				
Insulation class			F (per DIN VDE 0530 section 1)				
Housing coat			prime coat black (RAL 9005)				
<p>1) Housing temperature</p> <p>2) Winding temperature</p> <p>3) Depends on torque needs of application. For standard applications, see n_{max} in selection lists of motor/controller combination. For other applications, use the usable speed achieved with required torque via the speed/torque curve.</p> <p>4) Achievable maximum torque depends on drive controller. Only maximum torque M_{max} listed for a motor/controller combination is binding.</p> <p>5) No holding brake</p> <p>6) with 1000 min^{-1}.</p> <p>7) With deviating ambient temperatures see section 4.1.</p> <p>8) With deviating installation elevations see section 4.1.</p> <p>9) with proper mounting of power and feedback cables.</p> <p>10) No blower unit.</p>							

Fig. 10-6: Technical data MHP093C-035

Designation		Symbol	Unit	Data			
Motor type		MHP093C-058					
Motor overtemperature				$\Delta T_{60} \text{ K}^{1)}$	$\Delta T_{100} \text{ K}^{2)}$	$\Delta T_{60} \text{ K}^{1)}$ and $\Delta T_{100} \text{ K}^{2)}$	
Cooling type				natural convection	natural convection	surface cooled	liquid cooled
Characteristic motor speed	n_K		min^{-1}	4000	4000	4000	4000
Continuous torque at standstill	M_0		Nm	23.0	28.0	34.5	43.7
Continuous current at standstill	$I_{0(\text{eff})}$		A	18.9	23.6	28.4	35.9
Rated motor power	P_N		kW	1.6	3.8	5.4	8.3
Base speed ³⁾	n_N		min^{-1}	2000	2000	2000	2000
Nominal motor voltage	$U_{N(\text{eff})}$		V	168	174	178	189
Nominal motor current	$I_{N(\text{eff})}$		A	6.4	15.4	21.0	32.3
Nominal motor torque	M_N		Nm	7.8	18.3	25.6	39.4
Thermal time constant	T_{th}		min	75	75	35	25
Theoretical maximum torque ⁴⁾	M_{max}		Nm	88.0			
Peak current	$I_{max(\text{eff})}$		A	85.1			
Rotor moment of inertia ⁵⁾	J_M		kgm^2	30.0×10^{-4}			
Torque constant at 20°C	K_{mE}		Nm/A	1.34			
Voltage constant at 20°C ⁶⁾	$K_{E\text{eff}}$		$\text{V}/1000\text{min}^{-1}$	82.7			
Windings resistance at 20°C	R_{12}		Ω	0.32			
Windings inductance	L_{12}		mH	2.6			
Maximum speed	n_{max}		min^{-1}	6000			
Number of pole pairs	PZ			4			
Nominal frequency	f_N		Hz	133			
Data of equivalent circuit diagram							
	winding resistance	R_1	Ω	0.16			
	Rotary field inductance	L_{1-D}	mH	1.3			
Speed measuring system data							
	Number of lines	STR		2048			
	Counting direction	DIRECT:	pos./neg.	+			
Mass ^{4) 10)}	m_M		kg	23.5			
Max. Motor temperature (Winding)	T_{max}		°C	155			
Allowed ambient temperature ⁷⁾	T_{um}		°C	0 to +40			
Allowed storage / transport temp.	T_L		°C	-20 to +80			
Max. Installation elevation ⁸⁾			m	1000 meters above sea level			
Protection category ⁹⁾				IP 65			
Insulation class				F (per DIN VDE 0530 section 1)			
Housing coat				prime coat black (RAL 9005)			
<p>1) Housing temperature</p> <p>2) Winding temperature</p> <p>3) Depends on torque needs of application. For standard applications, see n_{max} in selection lists of motor/controller combination. For other applications, use the usable speed achieved with required torque via the speed/torque curve.</p> <p>4) Achievable maximum torque depends on drive controller. Only maximum torque M_{max} listed for a motor/controller combination is binding.</p> <p>5) No holding brake</p> <p>6) with 1000 min^{-1}.</p> <p>7) With deviating ambient temperatures see section 4.1.</p> <p>8) With deviating installation elevations see section 4.1.</p> <p>9) with proper mounting of power and feedback cables.</p> <p>10) No blower unit.</p>							

Fig. 10-7: Technical data MHP093C-058

Designation	Symbol	Unit	Data Holding brake
Motor type			MHP093A MHP093B MHP093C
Holding torque	M_H	Nm	22
Nominal voltage	U_N	V	DC 24 \pm 10%
Nominal current	I_N	A	0.71
Moment of inertia	J_B	kgm ²	3.6×10^{-4}
Separating time	t_2	ms	50
Link time	t_1	ms	25
Mass	m_B	kg	1.1

Fig. 10-8: Technical data holding brake MHP093 (Option)

Designation	Symbol	Unit	Data	
Motor type			MHP093B...	MHP093C...
Nominal power loss	P_{VN}	W	900	1000
Coolant temperature at entry ¹⁾	ϑ_{ein}	°C	+10 ... +40	
Coolant temperature increase at P_{VN}	$\Delta\vartheta_N$	°C	10	
Minimum required coolant flow through at $\Delta\vartheta_N$ ²⁾	Q_N	l/min	1.3	1.4
Pressure drop at Q_N ²⁾³⁾	Δp_N	bar	0.6	0.7
Maximum system pressure	p_{max}	bar	3.0	
Volume of coolant channel	V	l	0.05	0.06
1) Note relationship between coolant temperature at entry and actual ambient temperature: coolant entry temp. may not drop more than 5°C under actual ambient temperature (otherwise danger of condensation)! 2) with water as coolant 3) for deviating flow through values, see flow through diagram in section 6.				

Fig. 10-9: Technical data liquid cooling MHP093

Designation	Symbol	Unit	Data surface cooling	
Nominal voltage	U_N	V	1 x AC 230 \pm 10%	1 x AC 115 \pm 10%
Nominal current	I_N	A	0.2	0.4
Power consumption	S_N	VA	40	39
Frequency	f	Hz	50	60

Fig. 10-10: Technical data surface cooling MHP093 (Option)

10.2 Torque/speed curves

See next page.

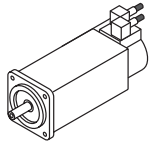

Insulated construction
Housing overtemperature $\Delta\theta = 60K$

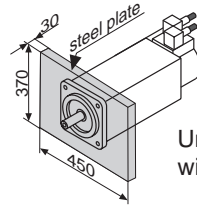

Uninsulated construction
winding overtemperatur $\Delta\theta = 100K$

k00mp81p.fh7

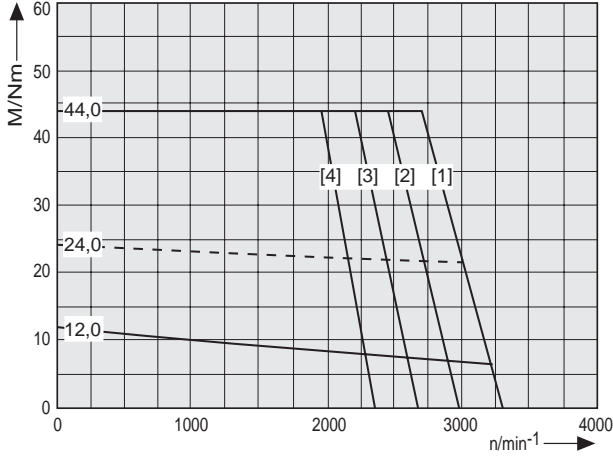

Speed/torque curve MHP093A-024

k093Amp024.fh7

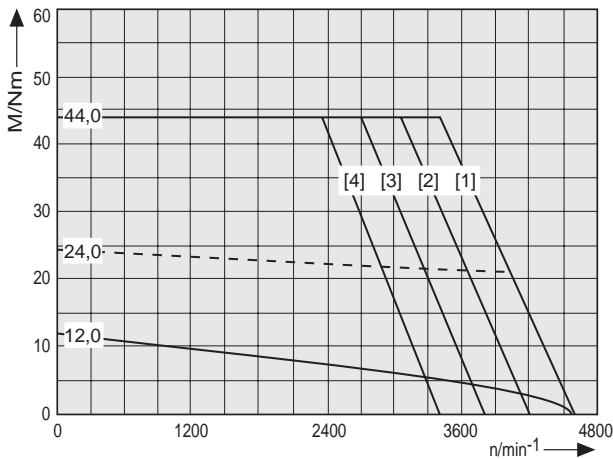
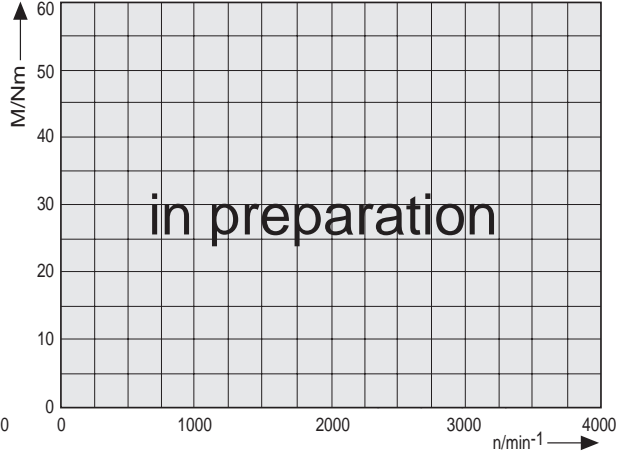

Speed/torque curve MHP093A-035

k093Amp035.fh7

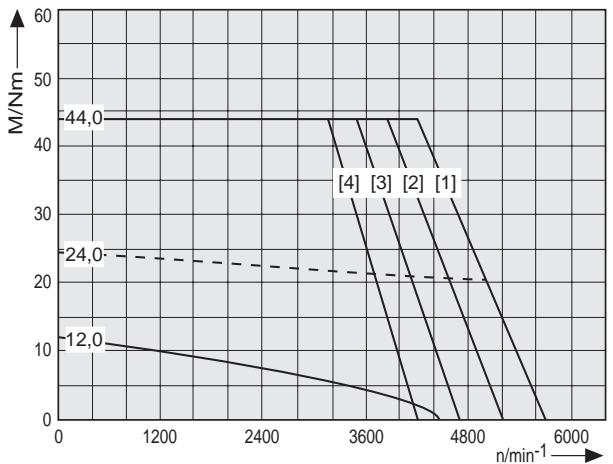
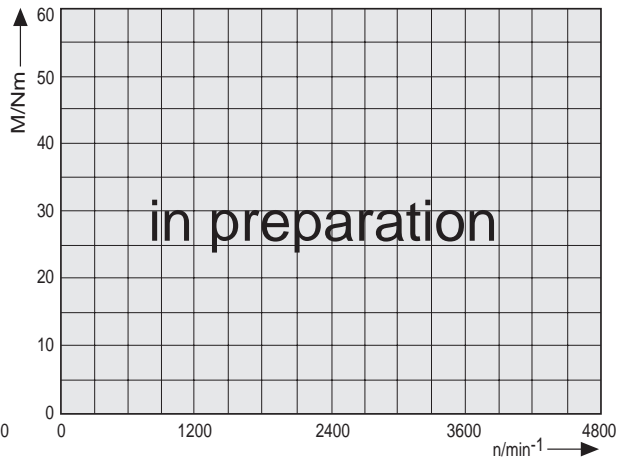

Speed/torque curve MHP093A-058

k093Amp058.fh7

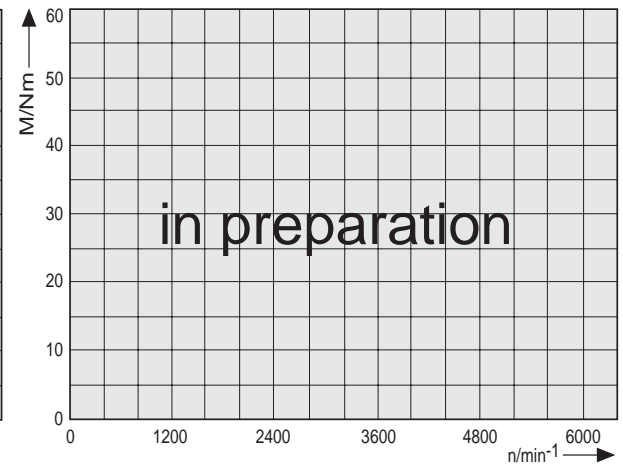
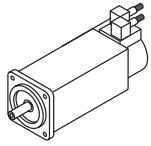
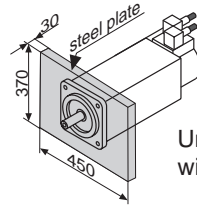

Fig. 10-11: Torque/speed curves MHP093A



Insulated construction
Housing overtemperature $\Delta\theta = 60\text{K}$



Uninsulated construction
winding overtemperature $\Delta\theta = 100\text{K}$

k00mp81p.fh7

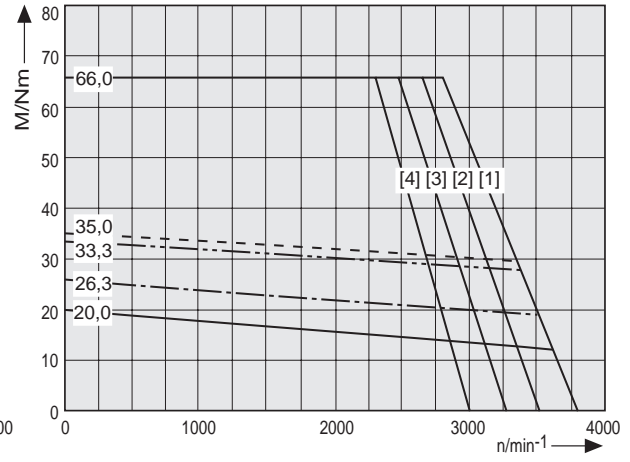
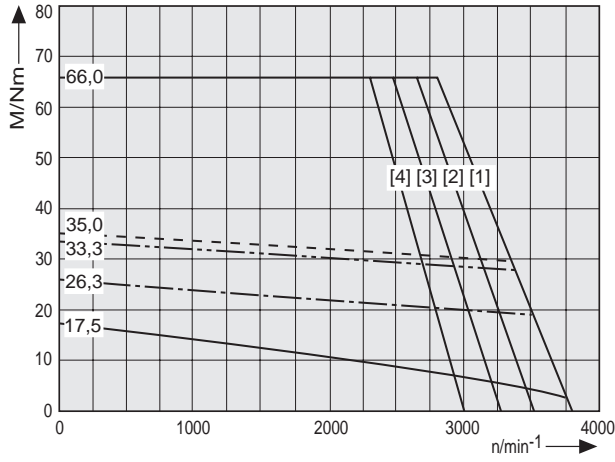

k093Bmhp035.fh7

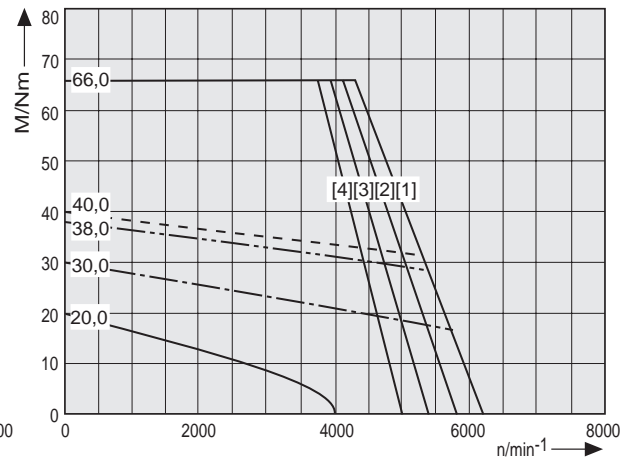
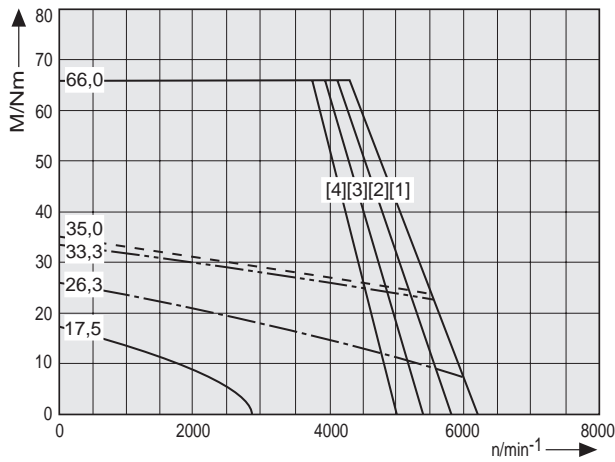

k093Bmhp058.fh7

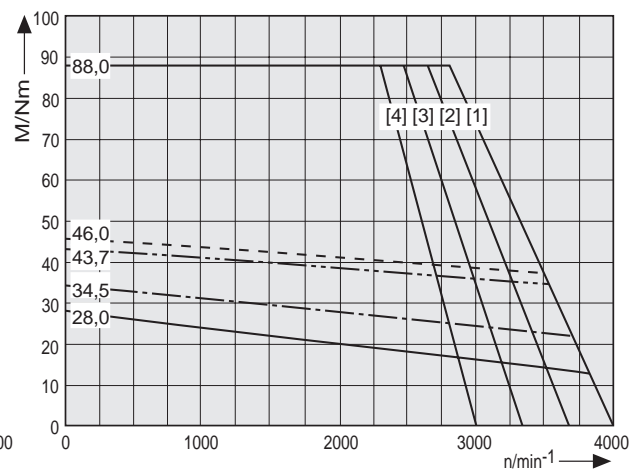
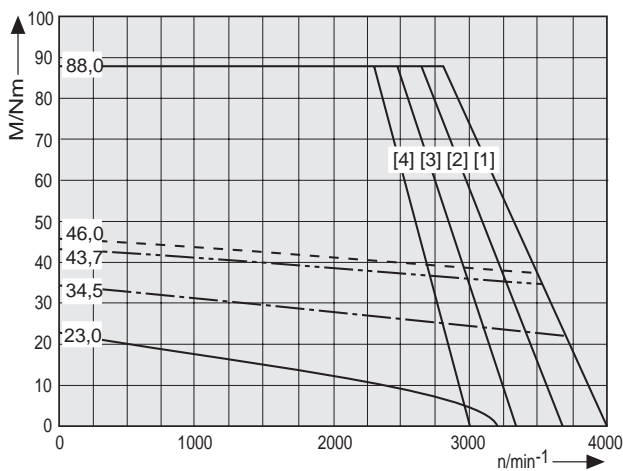

k093Cmhp035.fh7

Fig. 10-12: Torque/speed curves

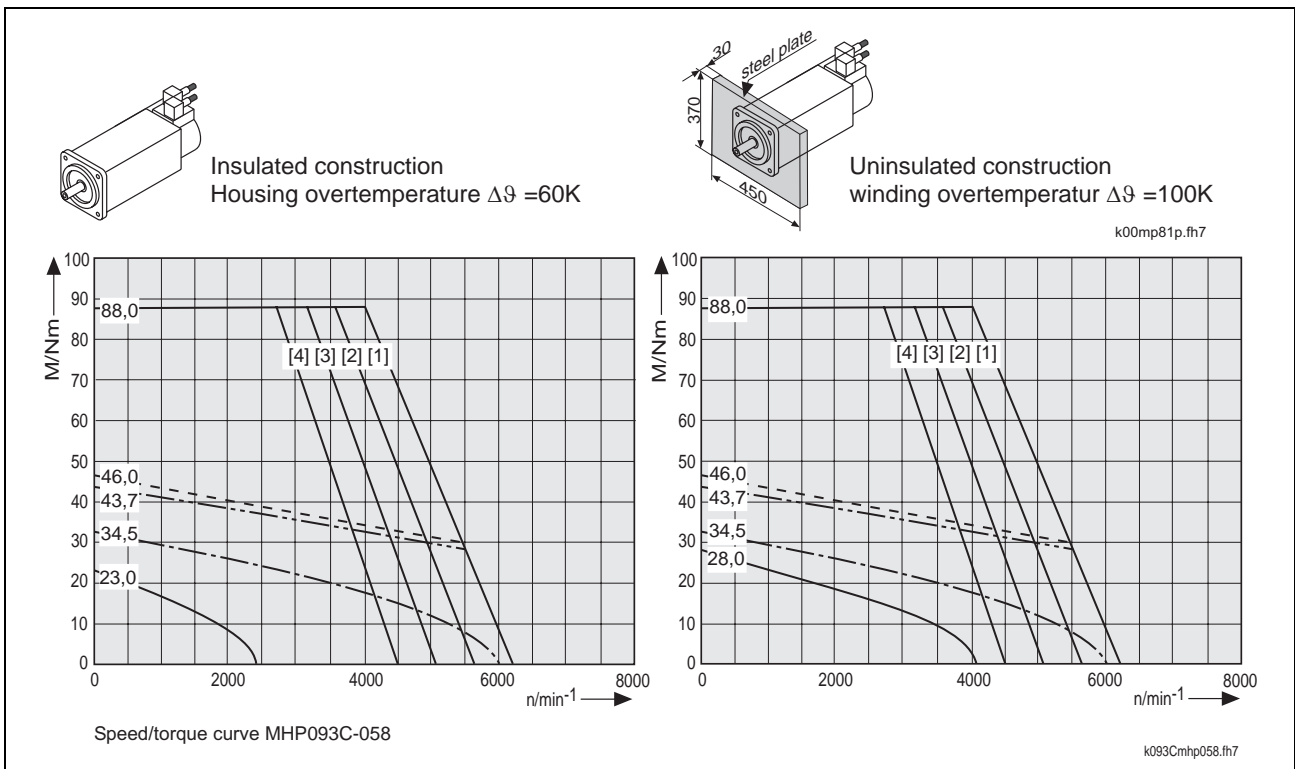

Fig. 10-13: Torque/speed curves

10.3 Maximum Shaft Load

Allowed maximum radial force F_{radial_max} and allowed radial force F_{radial} For details see section 4.6 „Shaft load“.

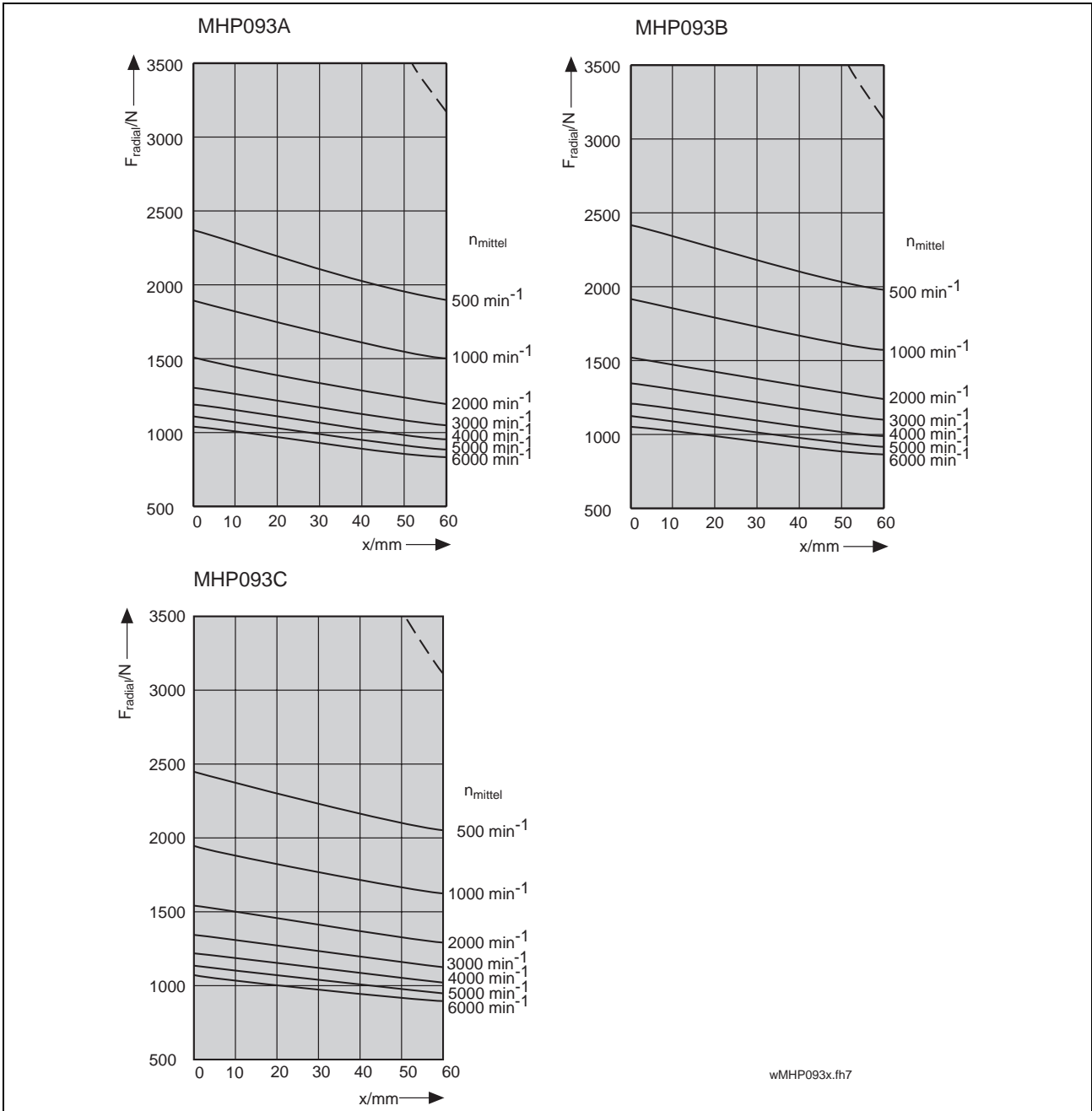

Fig. 10-14: MHP093: allowed maximum radial force F_{radial_max} and allowed radial force F_{radial}

Allowed axial force F_{axial}

$$F_{axial} = 0,24 \cdot F_{radial}$$

F_{axial} : allowed axial force in N
 F_{radial} : allowed radial force in N

Fig. 10-15: MHP093: allowed axial force F_{axial}

10.4 Dimensional data (standard cooling)

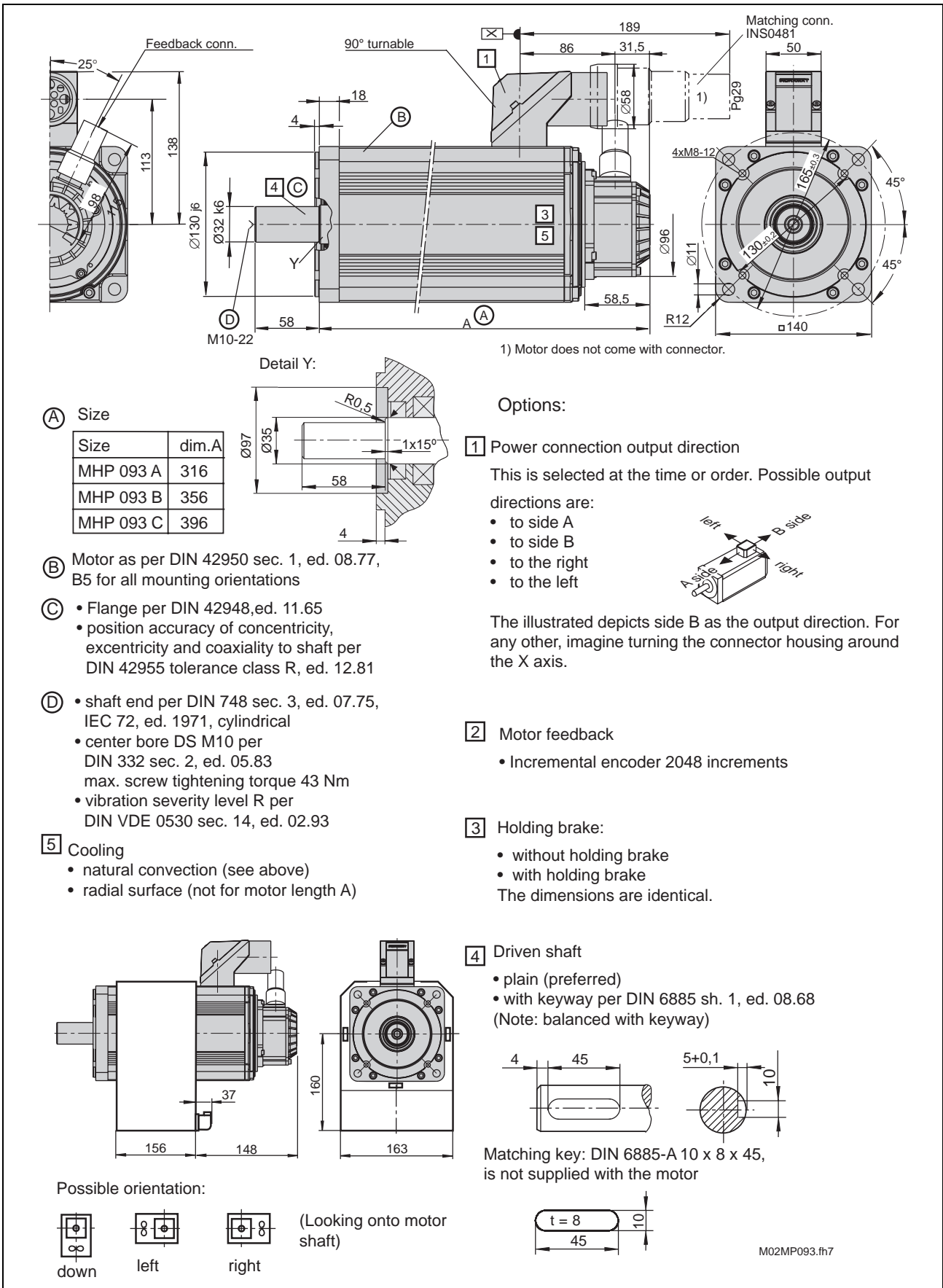

Fig. 10-16: Size sheet MHP093.-...-N

10.5 Dimensional data (liquid cooling)

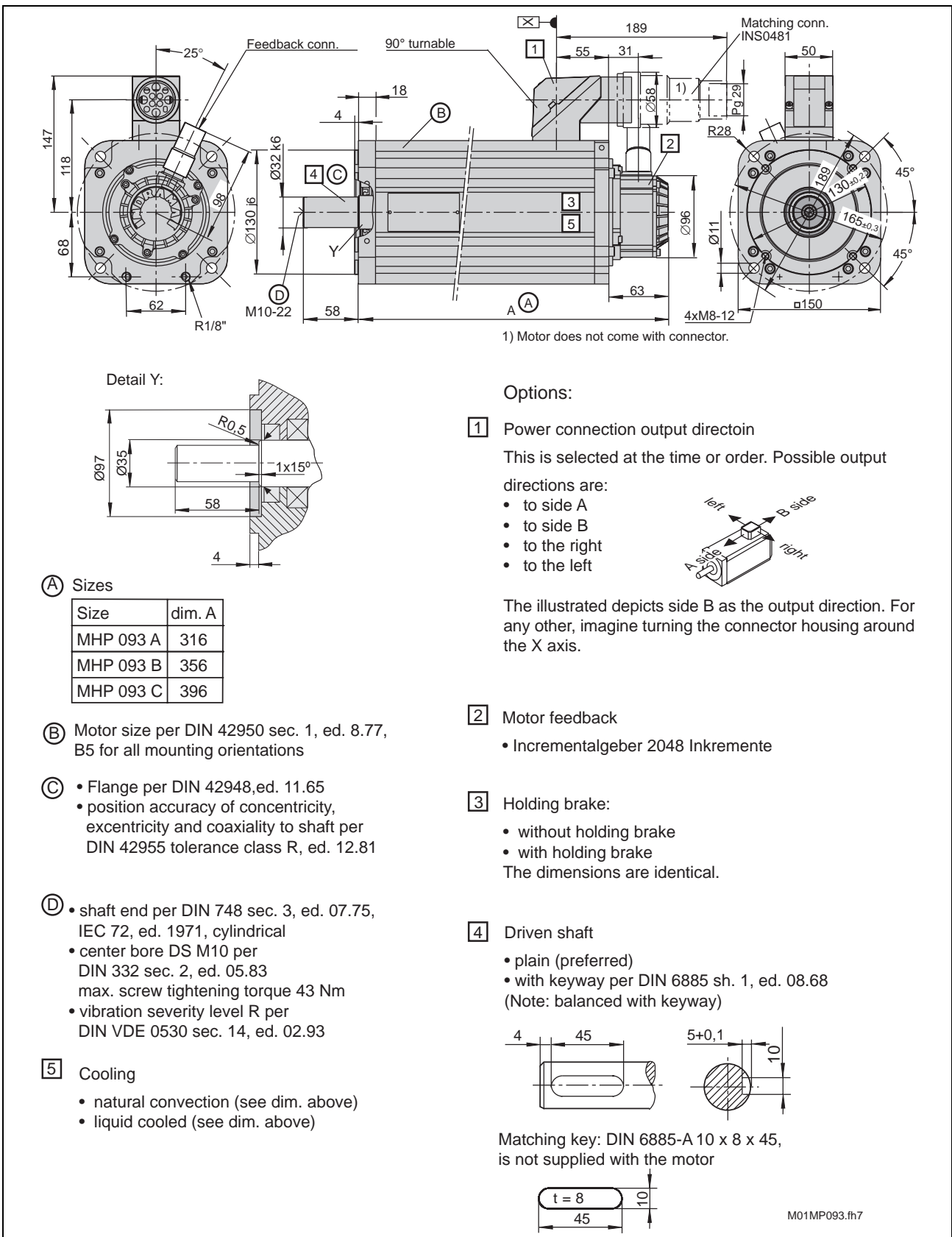

Fig. 10-17: Size sheet MHP093.-...-...-F

10.7 Blower units

Selecting the blower unit

Select the blower unit using the table below.

Motor type	Order designations for blower units	
	AC 115V / 60Hz	AC 230V / 50Hz
MHP093A-...-...-A	---	---
MHP093B-...-...-A	LEMD-RB090B2XX	LEMD-RB090B1XX
MHP093C-...-...-A	LEMD-RB090B2XX	LEMD-RB090B1XX
--- blower cannot be mounted		

Fig. 10-19: Blower units MHP093

Motor with mounted blower unit

To obtain a motor with mounted surface cooling, list the type designation of the radial blower unit as a subitem of the MHP motor noting the desired arrangement of the blower.

Order position	Designation
1	1 pc. digital AC motor MHP093B-035-NG0-BNNNNN
1.1	1 pc. Blower unit LEMD-RB090B2XX mounted an Pos. 1blowe on left

Fig. 10-20: Order information for MHP motor with mounted Blower unit

Motor with separate blower unit

If the blower is listed as a separate item, then it will be desired as such, i.e., not mounted.

Order position	Designation
1	1 pc. digital AC motor MHP093B-035-NG0-BNNNNN
2	1 pc. Blower unit LEMD-RB090B2XX

Fig. 10-21: Order information for MHP motor with separate blower unit

11 MHP095

11.1 Technical data

Designation	Symbol	Unit	Data			
Motor type	MHP095A-024					
Motor overtemperature			$\Delta T_{60} \text{ K}^{1)}$	$\Delta T_{100} \text{ K}^{2)}$	$\Delta T_{60} \text{ K}^{1)}$ and $\Delta T_{100} \text{ K}^{2)}$	
Cooling type			Natural convection	Natural convection	surface cooling liquid cooling	
Characteristic motor speed	n_K	min^{-1}			---	
Continuous torque at standstill	M_0	Nm			---	
Continuous current at standstill	$I_{0(\text{eff})}$	A			---	
Rated motor power	P_N	kW			---	
Base speed ³⁾	n_N	min^{-1}			---	
Nominal motor voltage	$U_{N(\text{eff})}$	V	in prep.	in prep.	---	
Nominal motor current	$I_{N(\text{eff})}$	A			---	
Nominal motor torque	M_N	Nm			---	
Thermal time constant	T_{th}	min			---	
Theoretical maximum torque ⁴⁾	M_{max}	Nm				
Peak current	$I_{\text{max}(\text{eff})}$	A				
Rotor moment of inertia ⁵⁾	J_M	kgm^2				
Torque constant at 20°C	K_{mH}	Nm/A				
Voltage constant at 20°C ⁶⁾	K_{Eeff}	$\text{V}/1000\text{min}^{-1}$				
Windings resistance at 20°C	R_{12}	Ω				
Windings inductance	L_{12}	mH				
Maximum speed	n_{max}	min^{-1}				
Number of pole pairs	PZ					
Nominal frequency	f_N	Hz				
Data of equivalent circuit diagram						
Winding resistance	R_1	Ω				
Rotary field inductance	L_{1-D}	mH				
Speed measuring system data						
Number of lines	STR				2048	
Counting direction	DIRECT:	pos./neg.			+	
Mass ^{4) 10)}	m_M	kg				
Max. Motor temperature (Winding)	T_{max}	°C			155	
Allowed ambient temperature ⁷⁾	T_{um}	°C			0 to +40	
Allowed storage / transport temp.	T_L	°C			-20 to +80	
Max. Installation elevation ⁸⁾		m			1000 meters above sea level	
Protection category ⁹⁾					IP 65	
Insulation class					F (per DIN VDE 0530 Section 1)	
Housing coat					Primary coat black (RAL 9005)	
1) Housing temperature 2) Winding temperature 3) Depends on torque needs of application. For standard applications, see n_{max} in selection lists of motor/controller combination. For other applications, use the usable speed achieved with required torque via the speed/torque curve. 4) Achievable maximum torque depends on drive controller. Only maximum torque M_{max} listed for a motor/controller combination is binding. 5) No holding brake 6) with 1000 min^{-1} . 7) With deviating ambient temperatures see section 4.1. 8) With deviating installation elevations see section 4.1. 9) with proper mounting of power and feedback cables. 10) No blower unit.						

Fig. 11-1: Technical data MHP095A-024

Designation		Symbol	Unit	Data		
Motor type		MHP095A-035				
Motor overtemperature				$\Delta T_{60} \text{ K}^{1)}$	$\Delta T_{100} \text{ K}^{2)}$	$\Delta T_{60} \text{ K}^{1)}$ and $\Delta T_{100} \text{ K}^{2)}$
Cooling type				Natural convection	Natural convection	surface cooling liquid cooling
Characteristic motor speed	n_K	min^{-1}	3000	3000	---	---
Continuous torque at standstill	M_0	Nm	12.0	13.5	---	---
Continuous current at standstill	$I_{0(\text{eff})}$	A	7.7	9.4	---	---
Rated motor power	P_N	kW	1.8	3.0	---	---
Base speed ³⁾	n_N	min^{-1}	3000	3000	---	---
Nominal motor voltage	$U_{N(\text{eff})}$	V	326	336	---	---
Nominal motor current	$I_{N(\text{eff})}$	A	3.6	6.6	---	---
Nominal motor torque	M_N	Nm	5.6	9.5	---	---
Thermal time constant	T_{th}	min	40	40	---	---
Theoretical maximum torque ⁴⁾	M_{max}	Nm	44.0			
Peak current	$I_{\text{max}(\text{eff})}$	A	34.7			
Rotor moment of inertia ⁵⁾	J_M	kgm^2	35.2×10^{-4}			
Torque constant at 20°C	K_{mH}	Nm/A	1.72			
Voltage constant at 20°C ⁶⁾	K_{Eeff}	V/1000 min^{-1}	105.7			
Windings resistance at 20°C	R_{12}	Ω	1.75			
Windings inductance	L_{12}	mH	8.5			
Maximum speed	n_{max}	min^{-1}	6000			
Number of pole pairs	PZ		4			
Nominal frequency	f_N	Hz	200			
Data of equivalent circuit diagram						
	Winding resistance	R_1	Ω	0,86		
	Rotary field inductance	L_{1-D}	mH	4,25		
Speed measuring system data						
	Number of lines	STR	2048			
	Counting direction	DIRECT:	pos./neg.	+		
Mass ^{4) 10)}	m_M	kg	15.0			
Max. Motor temperature (Winding)	T_{max}	°C	155			
Allowed ambient temperature ⁷⁾	T_{um}	°C	0 to +40			
Allowed storage / transport temp.	T_L	°C	-20 to +80			
Max. Installation elevation ⁸⁾		m	1000 meters above sea level			
Protection category ⁹⁾			IP 65			
Insulation class			F (per DIN VDE 0530 Section 1)			
Housing coat			Primary coat black (RAL 9005)			
1) Housing temperature						
2) Winding temperature						
3) Depends on torque needs of application. For standard applications, see n_{max} in selection lists of motor/controller combination. For other applications, use the usable speed achieved with required torque via the speed/torque curve.						
4) Achievable maximum torque depends on drive controller. Only maximum torque M_{max} listed for a motor/controller combination is binding.						
5) No holding brake						
6) with 1000 min^{-1} .						
7) With deviating ambient temperatures see section 4.1.						
8) With deviating installation elevations see section 4.1.						
9) with proper mounting of power and feedback cables.						
10) No blower unit.						

Fig. 11-2: Technical data MHP095A-035

Designation		Symbol	Unit	Data			
Motor type		MHP095A-058					
Motor overtemperature				$\Delta T_{60} \text{ K}^{1)}$	$\Delta T_{100} \text{ K}^{2)}$	$\Delta T_{60} \text{ K}^{1)}$ and $\Delta T_{100} \text{ K}^{2)}$	
Cooling type				Natural convection	Natural convection	surface cooling	liquid cooling
Characteristic motor speed	n_K		min^{-1}			---	---
Continuous torque at standstill	M_0		Nm			---	---
Continuous current at standstill	$I_{0(\text{eff})}$		A			---	---
Rated motor power	P_N		kW			---	---
Base speed ³⁾	n_N		min^{-1}			---	---
Nominal motor voltage	$U_{N(\text{eff})}$		V	in prep.	in prep.	---	---
Nominal motor current	$I_{N(\text{eff})}$		A			---	---
Nominal motor torque	M_N		Nm			---	---
Thermal time constant	T_{th}		min			---	---
Theoretical maximum torque ⁴⁾	M_{max}		Nm				
Peak current	$I_{\text{max}(\text{eff})}$		A				
Rotor moment of inertia ⁵⁾	J_M		kgm^2				
Torque constant at 20°C	K_{mH}		Nm/A				
Voltage constant at 20°C ⁶⁾	K_{Eff}		$\text{V}/1000\text{min}^{-1}$				
Windings resistance at 20°C	R_{12}		Ω				
Windings inductance	L_{12}		mH				
Maximum speed	n_{max}		min^{-1}				
Number of pole pairs	PZ						
Nominal frequency	f_N		Hz				
Data of equivalent circuit diagram							
	Winding resistance	R_1	Ω				
	Rotary field inductance	L_{1-D}	mH				
Speed measuring system data							
	Number of lines	STR				2048	
	Counting direction	DIRECT:	pos./neg.			+	
Mass ^{4) 10)}	m_M		kg				
Max. Motor temperature (Winding)	T_{max}		$^{\circ}\text{C}$			155	
Allowed ambient temperature ⁷⁾	T_{um}		$^{\circ}\text{C}$			0 to +40	
Allowed storage / transport temp.	T_L		$^{\circ}\text{C}$			-20 to +80	
Max. Installation elevation ⁸⁾			m			1000 meters above sea level	
Protection category ⁹⁾						IP 65	
Insulation class						F (per DIN VDE 0530 Section 1)	
Housing coat						Primary coat black (RAL 9005)	
<p>1) Housing temperature</p> <p>2) Winding temperature</p> <p>3) Depends on torque needs of application. For standard applications, see n_{max} in selection lists of motor/controller combination. For other applications, use the usable speed achieved with required torque via the speed/torque curve.</p> <p>4) Achievable maximum torque depends on drive controller. Only maximum torque M_{max} listed for a motor/controller combination is binding.</p> <p>5) No holding brake</p> <p>6) with 1000 min^{-1}.</p> <p>7) With deviating ambient temperatures see section 4.1.</p> <p>8) With deviating installation elevations see section 4.1.</p> <p>9) with proper mounting of power and feedback cables.</p> <p>10) No blower unit.</p>							

Fig. 11-3: Technical data MHP095A-058

Designation		Symbol	Unit	Data				
Motor type		MHP095B-035						
Motor overtemperature				$\Delta T_{60} \text{ K}^{1)}$	$\Delta T_{100} \text{ K}^{2)}$	$\Delta T_{60} \text{ K}^{1)}$ and $\Delta T_{100} \text{ K}^{2)}$		
Cooling type				Natural convection	Natural convection	surface cooling	liquid cooling	
Characteristic motor speed	n_K	min^{-1}	2500	2500	2500	2500	2500	
Continuous torque at standstill	M_0	Nm	17.5	21.0	26.3	33.3		
Continuous current at standstill	$I_{0(\text{eff})}$	A	10.9	13.5	16.4	20.7		
Rated motor power	P_N	kW	1.7	3.6	5.2	7.9		
Base speed ³⁾	n_N	min^{-1}	2500	2500	2500	2500		
Nominal motor voltage	$U_{N(\text{eff})}$	V	276	284	292	310		
Nominal motor current	$I_{N(\text{eff})}$	A	4.0	8.7	12.3	18.7		
Nominal motor torque	M_N	Nm	6.5	13.6	19.7	30.1		
Thermal time constant	T_{th}	min	60	60	30	20		
Theoretical maximum torque ⁴⁾	M_{max}	Nm	66					
Peak current	$I_{max(\text{eff})}$	A	49.1					
Rotor moment of inertia ⁵⁾	J_M	kgm^2	49.0×10^{-4}					
Torque constant at 20°C	K_{mH}	Nm/A	1.76					
Voltage constant at 20°C ⁶⁾	$K_{E\text{eff}}$	V/1000 min^{-1}	108.2					
Windings resistance at 20°C	R_{12}	Ω	0.99					
Windings inductance	L_{12}	mH	5.7					
Maximum speed	n_{max}	min^{-1}	6000					
Number of pole pairs	PZ		4					
Nominal frequency	f_N	Hz	167					
Data of equivalent circuit diagram								
	Winding resistance	R_1	Ω	0.50				
	Rotary field inductance	L_{1-D}	mH	2.85				
Speed measuring system data								
	Number of lines	STR	2048					
	Counting direction	DIRECT:	pos./neg.	+				
Mass ^{4) 10)}	m_M	kg	18.5					
Max. Motor temperature (Winding)	T_{max}	°C	155					
Allowed ambient temperature ⁷⁾	T_{um}	°C	0 to +40					
Allowed storage / transport temp.	T_L	°C	-20 to +80					
Max. Installation elevation ⁸⁾		m	1000 meters above sea level					
Protection category ⁹⁾			IP 65					
Insulation class			F (per DIN VDE 0530 Section 1)					
Housing coat			Primary coat black (RAL 9005)					
1) Housing temperature								
2) Winding temperature								
3) Depends on torque needs of application. For standard applications, see n_{max} in selection lists of motor/controller combination. For other applications, use the usable speed achieved with required torque via the speed/torque curve.								
4) Achievable maximum torque depends on drive controller. Only maximum torque M_{max} listed for a motor/controller combination is binding.								
5) No holding brake								
6) with 1000 min^{-1} .								
7) With deviating ambient temperatures see section 4.1.								
8) With deviating installation elevations see section 4.1.								
9) with proper mounting of power and feedback cables.								
10) No blower unit.								

Fig. 11-4: Technical data MHP095B-035

Designation		Symbol	Unit	Data	
Motor type		MHP095B-058			
Motor overtemperature		ΔT_{60}	K ¹⁾	ΔT_{100}	K ²⁾
Cooling type		Natural convection		Natural convection	surface cooling and liquid cooling
Characteristic motor speed	n_K		min ⁻¹	---	---
Continuous torque at standstill	M_0		Nm	---	---
Continuous current at standstill	$I_{0(eff)}$		A	---	---
Rated motor power	P_N		kW	---	---
Base speed ³⁾	n_N		min ⁻¹	---	---
Nominal motor voltage	$U_{N(eff)}$		V	in prep.	in prep.
Nominal motor current	$I_{N(eff)}$		A	---	---
Nominal motor torque	M_N		Nm	---	---
Thermal time constant	T_{th}		min	---	---
Theoretical maximum torque ⁴⁾	M_{max}		Nm		
Peak current	$I_{max(eff)}$		A		
Rotor moment of inertia ⁵⁾	J_M		kgm ²		
Torque constant at 20°C	K_{mH}		Nm/A		
Voltage constant at 20°C ⁶⁾	K_{Eff}		V/1000min ⁻¹		
Windings resistance at 20°C	R_{12}		Ω		
Windings inductance	L_{12}		mH		
Maximum speed	n_{max}		min ⁻¹		
Number of pole pairs	PZ				
Nominal frequency	f_N		Hz		
Data of equivalent circuit diagram					
	Winding resistance	R_1	Ω		
	Rotary field inductance	L_1-D	mH		
Speed measuring system data					
	Number of lines	STR		2048	
	Counting direction	DIRECT:	pos./neg.	+	
Mass ^{4) 10)}	m_M		kg		
Max. Motor temperature (Winding)	T_{max}		°C	155	
Allowed ambient temperature ⁷⁾	T_{um}		°C	0 to +40	
Allowed storage / transport temp.	T_L		°C	-20 to +80	
Max. Installation elevation ⁸⁾			m	1000 meters above sea level	
Protection category ⁹⁾				IP 65	
Insulation class				F (per DIN VDE 0530 Section 1)	
Housing coat				Primary coat black (RAL 9005)	
<p>1) Housing temperature 2) Winding temperature 3) Depends on torque needs of application. For standard applications, see n_{max} in selection lists of motor/controller combination. For other applications, use the usable speed achieved with required torque via the speed/torque curve. 4) Achievable maximum torque depends on drive controller. Only maximum torque M_{max} listed for a motor/controller combination is binding. 5) No holding brake 6) with 1000 min⁻¹. 7) With deviating ambient temperatures see section 4.1. 8) With deviating installation elevations see section 4.1. 9) with proper mounting of power and feedback cables. 10) No blower unit.</p>					

Fig. 11-5: Technical data MHP095B-058

Designation		Symbol	Unit	Data			
Motor type		MHP095C-035					
Motor overtemperature				$\Delta T_{60} \text{ K}^{1)}$	$\Delta T_{100} \text{ K}^{2)}$	$\Delta T_{60} \text{ K}^{1)}$ and $\Delta T_{100} \text{ K}^{2)}$	
Cooling type				Natural convection	Natural convection	surface cooling	liquid cooling
Characteristic motor speed	n_K	min^{-1}	2500	2500	2500	2500	
Continuous torque at standstill	M_0	Nm	23.0	28.0	34.5	43.7	
Continuous current at standstill	$I_{0(\text{eff})}$	A	14.0	17.5	21.0	26.6	
Rated motor power	P_N	kW	1.8	3.8	5.4	8.3	
Base speed ³⁾	n_N	min^{-1}	2000	2000	2000	2000	
Nominal motor voltage	$U_{N(\text{eff})}$	V	226	234	240	254	
Nominal motor current	$I_{N(\text{eff})}$	A	5.1	11.4	15.8	23.9	
Nominal motor torque	M_N	Nm	8.4	18.2	25.9	39.2	
Thermal time constant	T_{th}	min	75	75	35	25	
Theoretical maximum torque ⁴⁾	M_{max}	Nm	88.0				
Peak current	$I_{max(\text{eff})}$	A	63.0				
Rotor moment of inertia ⁵⁾	J_M	kgm^2	61.3×10^{-4}				
Torque constant at 20°C	K_{mH}	Nm/A	1.81				
Voltage constant at 20°C ⁶⁾	$K_{E\text{eff}}$	$\text{V}/1000\text{min}^{-1}$	111.0				
Windings resistance at 20°C	R_{12}	Ω	0.69				
Windings inductance	L_{12}	mH	4.4				
Maximum speed	n_{max}	min^{-1}	6000				
Number of pole pairs	PZ		4				
Nominal frequency	f_N	Hz	133				
Data of equivalent circuit diagram							
	Winding resistance	R_1	Ω	0.35			
	Rotary field inductance	L_{1-D}	mH	2.2			
Speed measuring system data							
	Number of lines	STR	2048				
	Counting direction	DIRECT:	pos./neg.	+			
Mass ^{4) 10)}	m_M	kg	22.5				
Max. Motor temperature (Winding)	T_{max}	$^{\circ}\text{C}$	155				
Allowed ambient temperature ⁷⁾	T_{um}	$^{\circ}\text{C}$	0 to +40				
Allowed storage / transport temp.	T_L	$^{\circ}\text{C}$	-20 to +80				
Max. Installation elevation ⁸⁾		m	1000 meters above sea level				
Protection category ⁹⁾			IP 65				
Insulation class			F (per DIN VDE 0530 Section 1)				
Housing coat			Primary coat black (RAL 9005)				
<p>1) Housing temperature</p> <p>2) Winding temperature</p> <p>3) Depends on torque needs of application. For standard applications, see n_{max} in selection lists of motor/controller combination. For other applications, use the usable speed achieved with required torque via the speed/torque curve.</p> <p>4) Achievable maximum torque depends on drive controller. Only maximum torque M_{max} listed for a motor/controller combination is binding.</p> <p>5) No holding brake</p> <p>6) with 1000 min^{-1}.</p> <p>7) With deviating ambient temperatures see section 4.1.</p> <p>8) With deviating installation elevations see section 4.1.</p> <p>9) with proper mounting of power and feedback cables.</p> <p>10) No blower unit.</p>							

Fig. 11-6: Technical data MHP095C-035

Designation		Symbol	Unit	Data	
Motor type		MHP095C-058			
Motor overtemperature		$\Delta T_{60} K$	¹⁾	$\Delta T_{100} K$	²⁾
Cooling type		Natural convection		Natural convection	surface cooling and liquid cooling
Characteristic motor speed	n_K	min^{-1}		---	---
Continuous torque at standstill	M_0	Nm		---	---
Continuous current at standstill	$I_{0(eff)}$	A		---	---
Rated motor power	P_N	kW		---	---
Base speed ³⁾	n_N	min^{-1}		---	---
Nominal motor voltage	$U_{N(eff)}$	V	in prep.	in prep.	---
Nominal motor current	$I_{N(eff)}$	A	in prep.	in prep.	---
Nominal motor torque	M_N	Nm	in prep.	in prep.	---
Thermal time constant	T_{th}	min	in prep.	in prep.	---
Theoretical maximum torque ⁴⁾	M_{max}	Nm			
Peak current	$I_{max(eff)}$	A			
Rotor moment of inertia ⁵⁾	J_M	kgm ²			
Torque constant at 20°C	K_{mH}	Nm/A			
Voltage constant at 20°C ⁶⁾	K_{Eff}	V/1000min ⁻¹			
Windings resistance at 20°C	R_{12}	Ω			
Windings inductance	L_{12}	mH			
Maximum speed	n_{max}	min^{-1}			
Number of pole pairs	PZ				
Nominal frequency	f_N	Hz			
Data of equivalent circuit diagram					
	Winding resistance	R_1	Ω		
	Rotary field inductance	L_1-D	mH		
Speed measuring system data					
	Number of lines	STR		2048	
	Counting direction	DIRECT: pos./neg.		+	
Mass ^{4) 10)}	m_M	kg			
Max. Motor temperature (Winding)	T_{max}	°C		155	
Allowed ambient temperature ⁷⁾	T_{um}	°C		0 to +40	
Allowed storage / transport temp.	T_L	°C		-20 to +80	
Max. Installation elevation ⁸⁾		m		1000 meters above sea level	
Protection category ⁹⁾				IP 65	
Insulation class				F (per DIN VDE 0530 Section 1)	
Housing coat				Primary coat black (RAL 9005)	
<p>1) Housing temperature</p> <p>2) Winding temperature</p> <p>3) Depends on torque needs of application. For standard applications, see n_{max} in selection lists of motor/controller combination. For other applications, use the usable speed achieved with required torque via the speed/torque curve.</p> <p>4) Achievable maximum torque depends on drive controller. Only maximum torque M_{max} listed for a motor/controller combination is binding.</p> <p>5) No holding brake</p> <p>6) with 1000 min^{-1}.</p> <p>7) With deviating ambient temperatures see section 4.1.</p> <p>8) With deviating installation elevations see section 4.1.</p> <p>9) with proper mounting of power and feedback cables.</p> <p>10) No blower unit.</p>					

Fig. 11-7: Technical data MHP095C-058

Designation	Symbol	Unit	Data holding brake
Motor type			MHP095A MHP095B MHP095C
holding torque	M_H	Nm	22
nominal voltage	U_N	V	DC 24 \pm 10%
nominal current	I_N	A	0.71
moment of inertia	J_B	kgm ²	3.6×10^{-4}
separating time	t_2	ms	50
link time	t_1	ms	25
Mass	m_B	kg	1.1

Fig. 11-8: Technical data holding brake MHP095 (Option)

Designation	Symbol	Unit	Data	
Motor type			MHP095B...	MHP095C...
Nominal power loss	P_{vN}	W	900	1000
Coolant entry temperature ¹⁾	ϑ_{ein}	°C	+10 ... +40	
Coolant temperature increase at P_{vN}	$\Delta\vartheta_N$	°C	10	
Minimum required coolant flow through at $\Delta\vartheta_N$ ²⁾	Q_N	l/min	1.3	1.4
Pressure drop at Q_N ²⁾³⁾	Δp_N	bar	0.6	0.7
Maximum system pressure	p_{max}	bar	3.0	
Volume of coolant channel	V	l	0.05	0.06
1) Note relationship between coolant temperature at entry and actual ambient temperature: coolant entry temp. may not drop more than 5°C under actual ambient temperature (otherwise danger of condensation)! 2) with water as coolant 3) for deviating flow through values, see flow through diagram in section 6.				

Fig. 11-9: Technical data liquid cooled MHP095

Designation	Symbol	Unit	Data surface cooling	
nominal voltage	U_N	V	1 x AC 230 \pm 10%	1 x AC 115 \pm 10%
nominal current	I_N	A	0.2	0.4
power consumption	S_N	VA	40	39
frequency	f	Hz	50	60

Fig. 11-10: Technical data surface cooled MHP095 (Option)

11.2 Torque/speed curves

See next page.

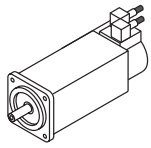

Insulated construction
Housing overtemperature $\Delta\theta = 60K$

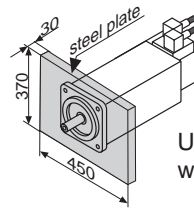

Uninsulated construction
winding overtemperature $\Delta\theta = 100K$

k00mp81p.fh7

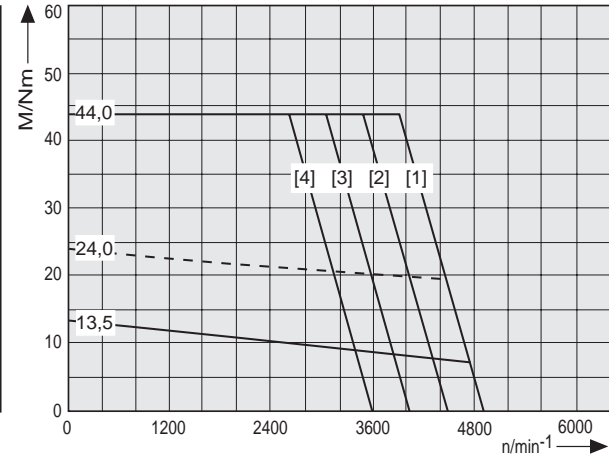
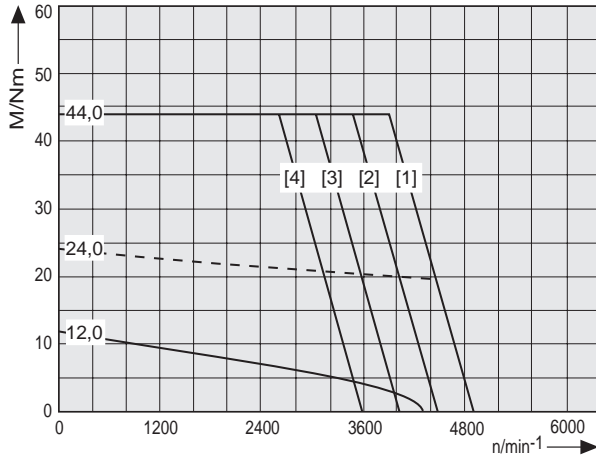

k095Amhp035.fh7

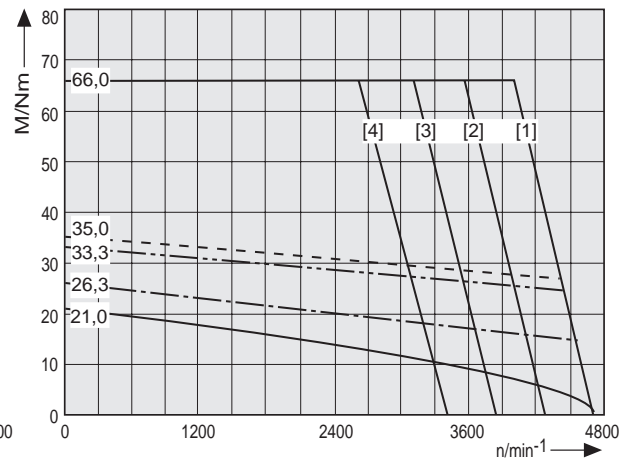
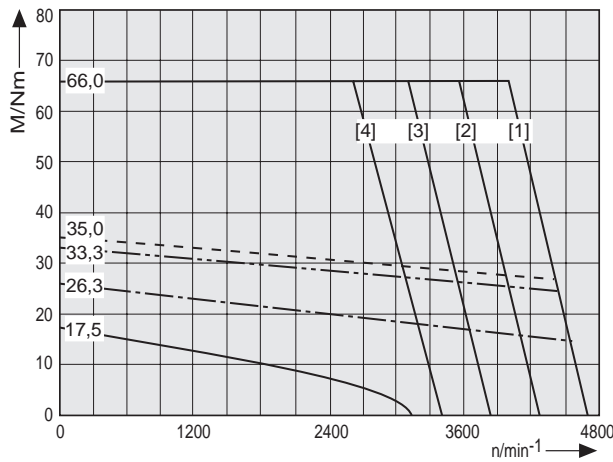

k095bmhp035.fh7

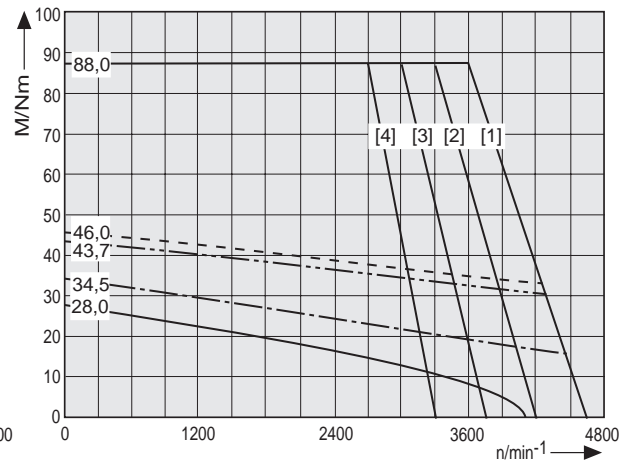
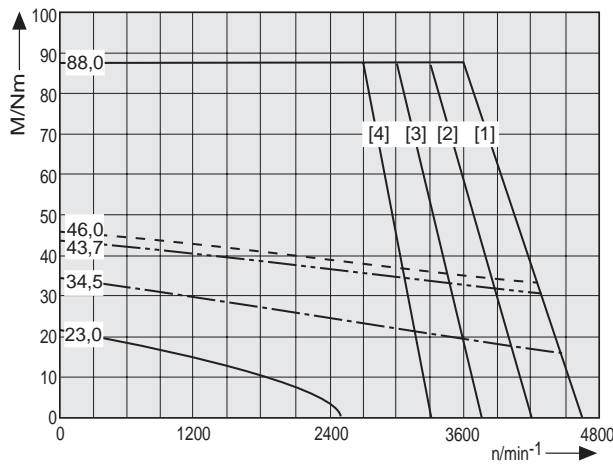

k095cmhp035.fh7

Fig. 11-11: Torque/speed curves MHP095A

11.3 Maximum Shaft Load

Allowed maximum radial force $F_{\text{radial_max}}$ and allowed radial force F_{radial} For details see section 4.6 Shaft load“.

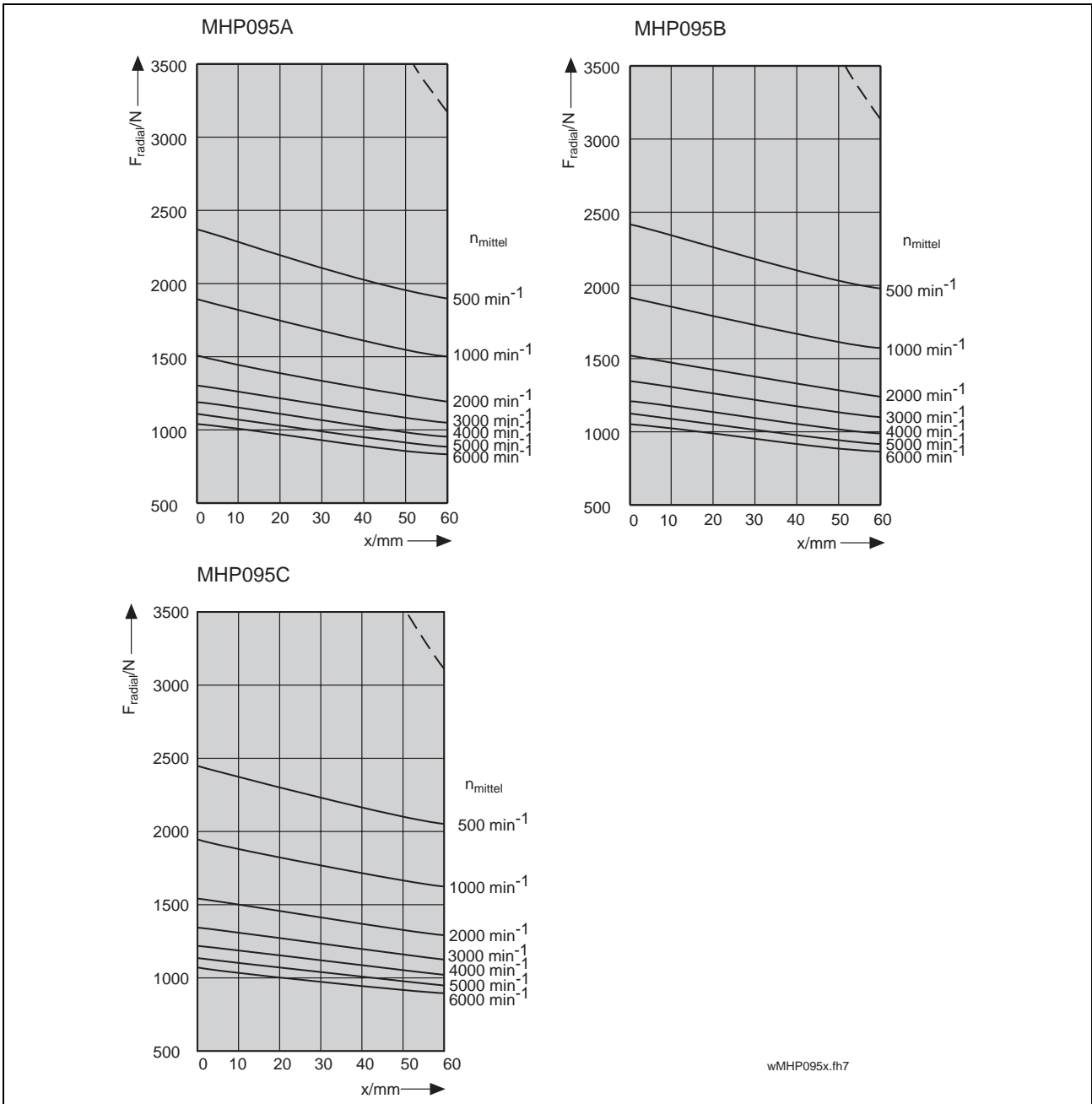

Fig. 11-12: MHP095: allowed maximum radial force $F_{\text{radial_max}}$ and allowed radial force F_{radial}

Allowed axial force F_{axial}

$$F_{\text{axial}} = 0,24 \cdot F_{\text{radial}}$$

F_{axial} : allowed axial force in N
 F_{radial} : allowed radial force in N

Fig. 11-13: MHP095: allowed axial force F_{axial}

11.4 Dimensional data (standard cooling)

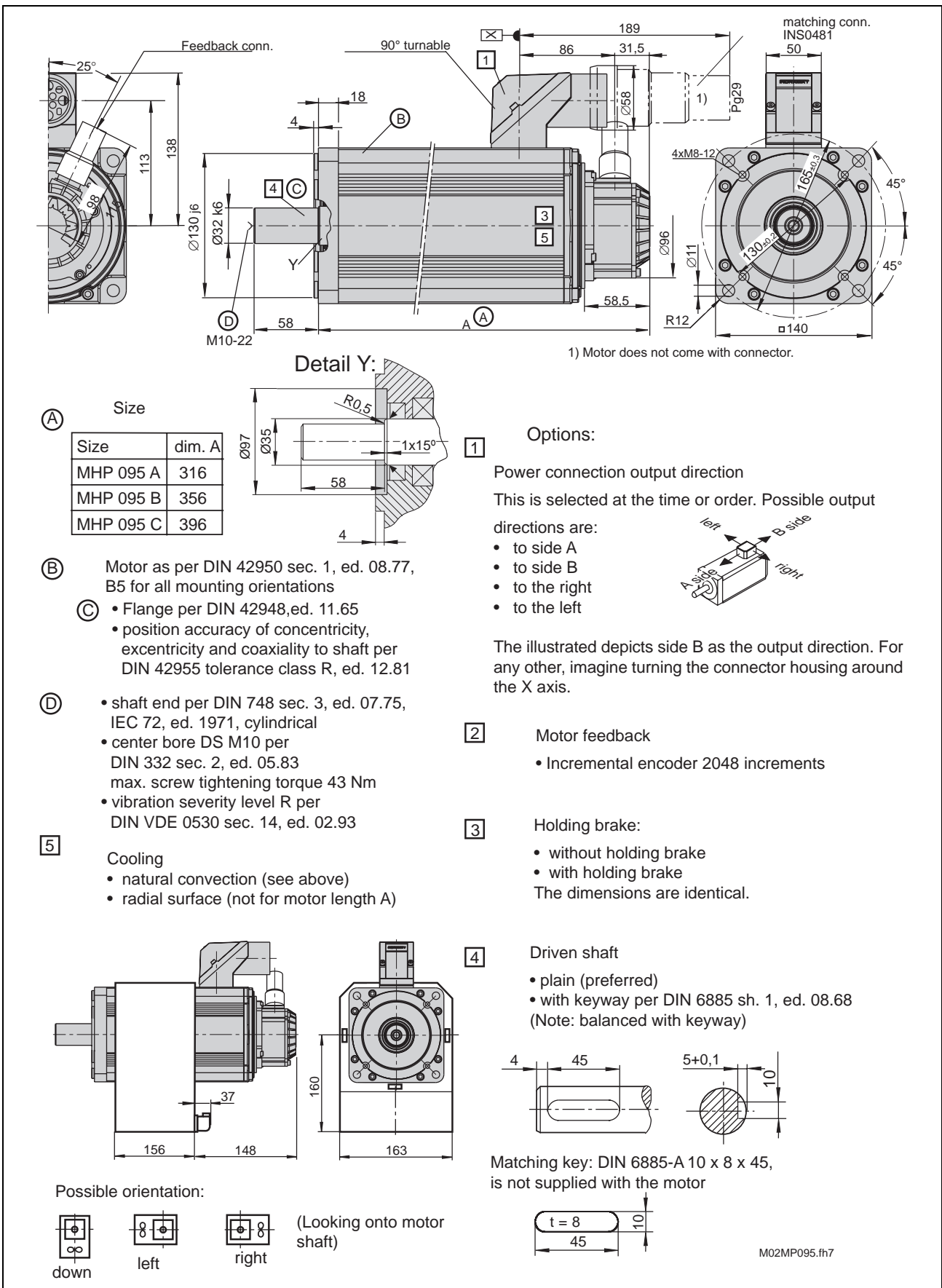

Fig. 11-14: Size sheet MHP095.-...-N

11.5 Dimensional data (liquid cooling)

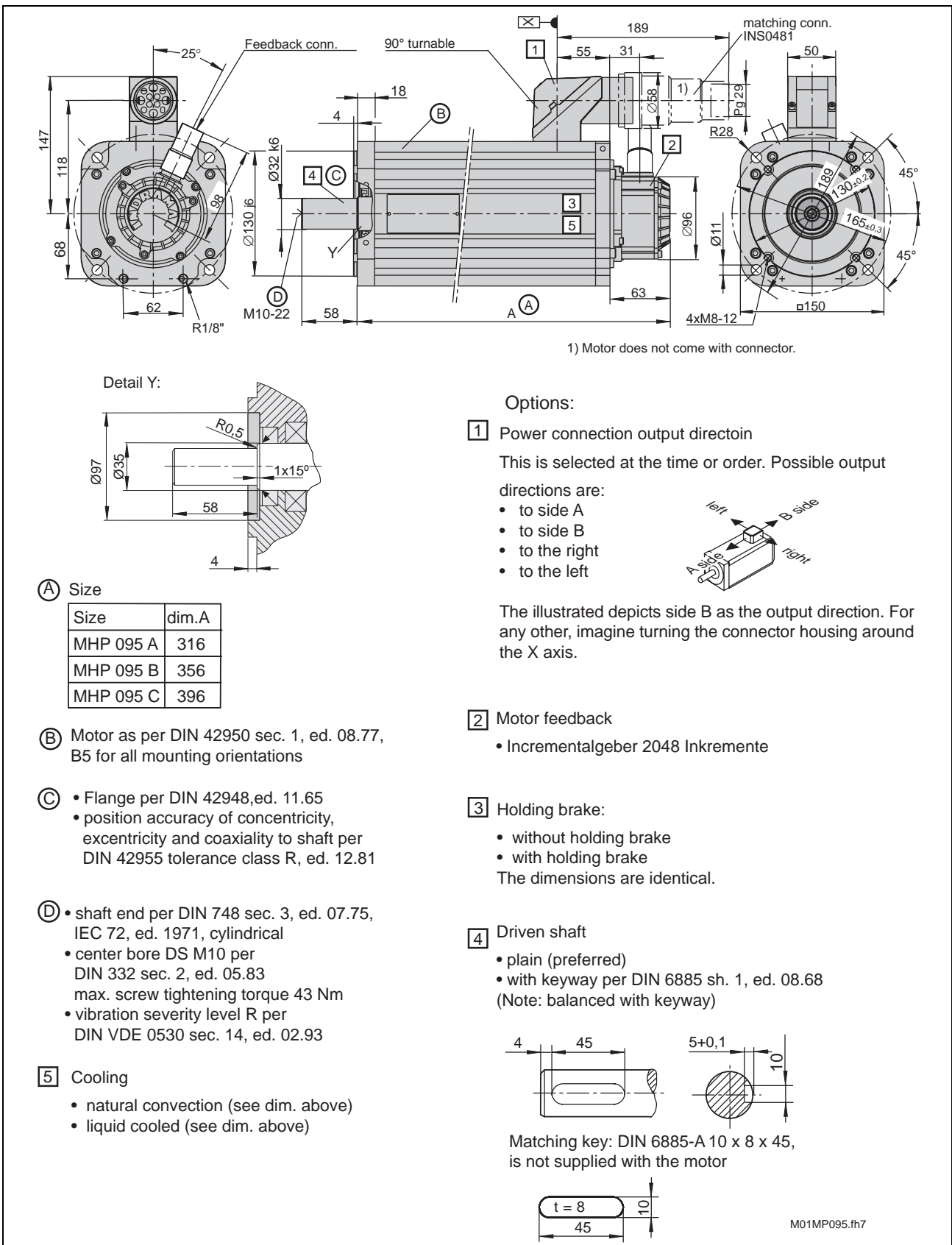

Fig. 11-15: Size sheet MHP095.-...-...-F

11.6 Available versions and type codes

Abbrev. Column	1	2	3	4	5	6	7	8	9	1	2	3	4	5	6	7	8	9	0	1	2	3	4	5	6	7	8	9	0	1	2	3	4	5	6	7	8	9	0	
Example:	M	H	P	0	9	5	B	-	0	3	5	-	H	G	0	-	B	N	N	N	N	N																		

1. Product group
 - 1.1 MHP..... = MHP

2. Motor size
 - 2.1 95..... = 095

3. Motor length ①
 - 3.1 Lengths..... = A, B, C

4. Windings code
 - 4.1 024..... = 024
 - 4.2 035..... = 035
 - 4.3 058..... = 058

5. Motor feedback
 - 5.1 Incremental encoder, 2.048 increments..... = H

6. Driven shaft
 - 6.1 plain shaft (with shaft sealing ring)..... = G
 - 6.2 Shaft with key per DIN 6885-Page 1 (with shaft sealing ring)..... = P

7. Holding brake
 - 7.1 without holding brake..... = 0
 - 7.2 with holding brake 22,0 Nm..... = 1

8. Output direction of power connection ②
 - 8.1 Connector to side A..... = A
 - 8.2 Connector to side B..... = B
 - 8.3 Connector to the left..... = L
 - 8.4 Connector to the right..... = R

9. Housing type ③
 - 9.1 for liquid cooling..... = F
 - 9.2 natural convection, standard..... = N

10. Other design
 - 10.1 none..... = NNNN

11. Standard reference

<u>Standard</u>	<u>Designation</u>	<u>Edition</u>
DIN 6885-1	Drive Type with Fastenings without Taper Action; Parallel Keys, Keyways, Deep Pattern	1968 August

Note:

- ① Motor lengths "A" only with housing type "N" available; no surface cooling available
- ② Looking from front onto driven shaft (see picture 1)
- ③ Housing type "F" for liquid cooling, natural convection and surface cooling
Housing type "N" for natural convection and surface cooling

Illustration example: MHP095

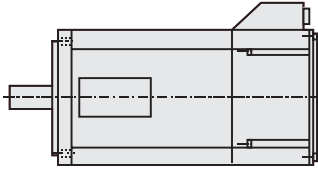

Position of power connection = top

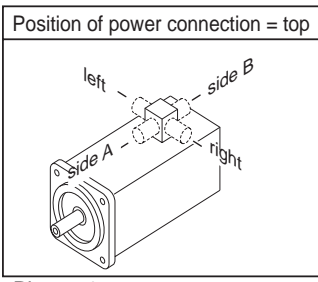

Picture 1

T01mhp095.fh7

Fig. 11-16: type codes MHP095

11.7 Blower Units

Selecting the blower unit

Select blower unit from table below.

Motor type	Order designations of blower units	
	AC 115V / 60Hz	AC 230V / 50Hz
MHP095A-...-...-A	---	---
MHP095B-...-...-A	LEMD-RB090B2XX	LEMD-RB090B1XX
MHP095C-...-...-A	LEMD-RB090B2XX	LEMD-RB090B1XX
--- not possible to mount a blower		

Fig. 11-17: Blower units MHP095

Motor with mounted blower unit

To obtain a motor with mounted surface cooling, list the type designation of the radial blower unit as a subitem of the MHP motor noting the desired arrangement of the blower.

Order position	Designation
1	1 pc. digital AC motor MHP095B-035-NG0-BNNNNN
1.1	1 pc. blower unit LEMD-RB090B2XX mounted to pos. 1 blower on left

Fig. 11-18: Order designations for MHP motor with blower unit mounted

Motor with separate blower unit

If the blower is listed as a separate item, then it will be desired as such, i.e., not mounted.

Order position	Designation
1	1 pc. digital AC motor MHP095B-035-NG0-BNNNNN
2	1 pc. blower unit LEMD-RB090B2XX

Fig. 11-19: order designations for MHP motor with separate blower unit

12 MHP112

12.1 Technical data

Designation	Symbol	Unit	Data			
Motor type	MHP112A-024					
Motor overtemperature			$\Delta T_{60} \text{ K}^{1)}$	$\Delta T_{100} \text{ K}^{2)}$	$\Delta T_{60} \text{ K}^{1)}$ and $\Delta T_{100} \text{ K}^{2)}$	
Cooling type			natural convection	natural convection	surface cooled	liquid cooled
Characteristic motor speed	n_K	min^{-1}	2000		---	---
Continuous torque at standstill	M_0	Nm	15.0		---	---
Continuous current at standstill	$I_{0(\text{eff})}$	A	9.2		---	---
Rated motor power	P_N	kW	2.6		---	---
Base speed ³⁾	n_N	min^{-1}	2500		---	---
Nominal motor voltage	$U_{N(\text{eff})}$	V	313	in prep.	---	---
Nominal motor current	$I_{N(\text{eff})}$	A	6.2		---	---
Nominal motor torque	M_N	Nm	10.1		---	---
Thermal time constant	T_{th}	min	90		---	---
Theoretical maximum torque ⁴⁾	M_{max}	Nm	54.0			
Peak current	$I_{\text{max}(\text{eff})}$	A	41.4			
Rotor moment of inertia ⁵⁾	J_M	kgm^2	110×10^{-4}			
Torque constant at 20°C	K_{mE}	Nm/A	1.89			
Voltage constant at 20°C ⁶⁾	$K_{E\text{eff}}$	V/1000min ⁻¹	116.4			
Windings resistance at 20°C	R_{12}	Ω	1.45			
Windings inductance	L_{12}	mH	14.0			
Maximum speed	n_{max}	min^{-1}	4500			
Number of pole pairs	PZ		4			
Nominal frequency	f_N	Hz	167			
Data of equivalent circuit diagram						
Windings resistance	R_1	Ω	0.73			
Rotary field inductance	L_{1-D}	mH	7.0			
Speed measuring system data						
Number of lines	STR		2048			
Counting direction	DIRECT:	pos./neg.	+			
Mass ^{4) 10)}	m_M	kg	23.0			
Max. Motor temperature (Winding)	T_{max}	°C	155			
Allowed ambient temperature ⁷⁾	T_{um}	°C	0 to +40			
Allowed storage / transport temp.	T_L	°C	-20 to +80			
Max. Installation elevation ⁸⁾		m	1000 meters above sea level			
Protection category ⁹⁾			IP 65			
Insulation class			F (per DIN VDE 0530 Section 1)			
Housing coat			Prime coat black (RAL 9005)			
<p>1) Housing temperature 2) Winding temperature 3) Depends on torque needs of application. For standard applications, see n_{max} in selection lists of motor/controller combination. For other applications, use the usable speed achieved with required torque via the speed/torque curve. 4) Achievable maximum torque depends on drive controller. Only maximum torque M_{max} listed for a motor/controller combination is binding. 5) No holding brake 6) with 1000 min⁻¹. 7) With deviating ambient temperatures see section 4.1. 8) With deviating installation elevations see section 4.1. 9) with proper mounting of power and feedback cables. 10) No blower unit.</p>						

Fig. 12-1: Technical data MHP112A-024

Designation		Symbol	Unit	Data		
Motor type		MHP112A-058				
Motor overtemperature				$\Delta T_{60} \text{ K}^{1)}$	$\Delta T_{100} \text{ K}^{2)}$	$\Delta T_{60} \text{ K}^{1)}$ and $\Delta T_{100} \text{ K}^{2)}$
Cooling type				natural convection	natural convection	surface cooled liquid cooled
Characteristic motor speed	n_K	min^{-1}	3500		---	---
Continuous torque at standstill	M_0	Nm	15.0		---	---
Continuous current at standstill	$I_{0(\text{eff})}$	A	12.1		---	---
Rated motor power	P_N	kW	2.5		---	---
Base speed ³⁾	n_N	min^{-1}	3500		---	---
Nominal motor voltage	$U_{N(\text{eff})}$	V	322	in prep.	---	---
Nominal motor current	$I_{N(\text{eff})}$	A	5.5		---	---
Nominal motor torque	M_N	Nm	6.8		---	---
Thermal time constant	T_{th}	min	90		---	---
Theoretical maximum torque ⁴⁾	M_{max}	Nm	54.0			
Peak current	$I_{\text{max}(\text{eff})}$	A	54.5			
Rotor moment of inertia ⁵⁾	J_M	kgm^2	110×10^{-4}			
Torque constant at 20°C	K_{mE}	Nm/A	1.44			
Voltage constant at 20°C ⁶⁾	$K_{E\text{eff}}$	V/1000min ⁻¹	89.0			
Windings resistance at 20°C	R_{12}	Ω	0.86			
Windings inductance	L_{12}	mH	7.8			
Maximum speed	n_{max}	min^{-1}	4500			
Number of pole pairs	PZ		4			
Nominal frequency	f_N	Hz	233			
Data of equivalent circuit diagram						
	Windings resistance	R_1	Ω	0.43		
	Rotary field inductance	L_{1-D}	mH	3.9		
Speed measuring system data						
	Number of lines	STR	2048			
	Counting direction	DIRECT:	pos./neg.	+		
Mass ^{4) 10)}	m_M	kg	48,0			
Max. Motor temperature (Winding)	T_{max}	°C	155			
Allowed ambient temperature ⁷⁾	T_{um}	°C	0 to +40			
Allowed storage / transport temp.	T_L	°C	-20 to +80			
Max. Installation elevation ⁸⁾		m	1000 meters above sea level			
Protection category ⁹⁾			IP 65			
Insulation class			F (per DIN VDE 0530 Section 1)			
Housing coat			Prime coat black (RAL 9005)			
<p>1) Housing temperature 2) Winding temperature 3) Depends on torque needs of application. For standard applications, see n_{max} in selection lists of motor/controller combination. For other applications, use the usable speed achieved with required torque via the speed/torque curve. 4) Achievable maximum torque depends on drive controller. Only maximum torque M_{max} listed for a motor/controller combination is binding. 5) No holding brake 6) with 1000 min⁻¹. 7) With deviating ambient temperatures see section 4.1. 8) With deviating installation elevations see section 4.1. 9) with proper mounting of power and feedback cables. 10) No blower unit.</p>						

Fig. 12-2: Technical data MHP112A-058

Designation		Symbol	Unit	Data				
Motor type		MHP112B-024						
Motor overtemperature				$\Delta T_{60} \text{ K}^{1)}$	$\Delta T_{100} \text{ K}^{2)}$	$\Delta T_{60} \text{ K}^{1)}$ and $\Delta T_{100} \text{ K}^{2)}$		
Cooling type				natural convection	natural convection	surface cooled	liquid cooled	
Characteristic motor speed	n_K	min^{-1}	2000	2000	2000	---		
Continuous torque at standstill	M_0	Nm	28.0	31.0	42.0	---		
Continuous current at standstill	$I_{0(\text{eff})}$	A	15.4	17.6	23.1	---		
Rated motor power	P_N	kW	3.9	6.0	8.9	---		
Base speed ³⁾	n_N	min^{-1}	2500	2500	2500	---		
Nominal motor voltage	$U_{N(\text{eff})}$	V	336	349	367	---		
Nominal motor current	$I_{N(\text{eff})}$	A	8.3	13.2	18.6	---		
Nominal motor torque	M_N	Nm	15.0	23.2	33.9	---		
Thermal time constant	T_{th}	min	90	90	40	---		
Theoretical maximum torque ⁴⁾	M_{max}	Nm	102.0					
Peak current	$I_{\text{max}(\text{eff})}$	A	69.3					
Rotor moment of inertia ⁵⁾	J_M	kgm^2	192×10^{-4}					
Torque constant at 20°C	K_{mE}	Nm/A	2.11					
Voltage constant at 20°C ⁶⁾	$K_{E\text{eff}}$	$\text{V}/1000\text{min}^{-1}$	130.0					
Windings resistance at 20°C	R_{12}	Ω	0.58					
Windings inductance	L_{12}	mH	7.6					
Maximum speed	n_{max}	min^{-1}	4500					
Number of pole pairs	PZ		4					
Nominal frequency	f_N	Hz	166					
Data of equivalent circuit diagram								
	Windings resistance	R_1	Ω	0.29				
	Rotary field inductance	L_{1-D}	mH	3.8				
Speed measuring system data								
	Number of lines	STR	2048					
	Counting direction	DIRECT:	pos./neg.	+				
Mass ^{4) 10)}	m_M	kg	48.0					
Max. Motor temperature (Winding)	T_{max}	$^{\circ}\text{C}$	155					
Allowed ambient temperature ⁷⁾	T_{um}	$^{\circ}\text{C}$	0 to +40					
Allowed storage / transport temp.	T_L	$^{\circ}\text{C}$	-20 to +80					
Max. Installation elevation ⁸⁾		m	1000 meters above sea level					
Protection category ⁹⁾			IP 65					
Insulation class			F (per DIN VDE 0530 Section 1)					
Housing coat			Prime coat black (RAL 9005)					
<p>1) Housing temperature</p> <p>2) Winding temperature</p> <p>3) Depends on torque needs of application. For standard applications, see n_{max} in selection lists of motor/controller combination. For other applications, use the usable speed achieved with required torque via the speed/torque curve.</p> <p>4) Achievable maximum torque depends on drive controller. Only maximum torque M_{max} listed for a motor/controller combination is binding.</p> <p>5) No holding brake</p> <p>6) with 1000 min^{-1}.</p> <p>7) With deviating ambient temperatures see section 4.1.</p> <p>8) With deviating installation elevations see section 4.1.</p> <p>9) with proper mounting of power and feedback cables.</p> <p>10) No blower unit.</p>								

Fig. 12-3: Technical data MHP112B-024

Designation		Symbol	Unit	Data			
Motor type		MHP112B-035					
Motor overtemperature				$\Delta T_{60} \text{ K}^{1)}$	$\Delta T_{100} \text{ K}^{2)}$	$\Delta T_{60} \text{ K}^{1)}$ and $\Delta T_{100} \text{ K}^{2)}$	
Cooling type				natural convection	natural convection	surface cooled	liquid cooled
Characteristic motor speed	n_K		min^{-1}				---
Continuous torque at standstill	M_0		Nm				---
Continuous current at standstill	$I_{0(\text{eff})}$		A				---
Rated motor power	P_N		kW				---
Base speed ³⁾	n_N		min^{-1}				---
Nominal motor voltage	$U_{N(\text{eff})}$		V	in prep.	in prep.	in prep.	---
Nominal motor current	$I_{N(\text{eff})}$		A				---
Nominal motor torque	M_N		Nm				---
Thermal time constant	T_{th}		min				---
Theoretical maximum torque ⁴⁾	M_{max}		Nm				---
Peak current	$I_{\text{max}(\text{eff})}$		A				---
Rotor moment of inertia ⁵⁾	J_M		kgm^2				---
Torque constant at 20°C	K_{mE}		Nm/A				---
Voltage constant at 20°C ⁶⁾	K_{Eff}		$\text{V}/1000\text{min}^{-1}$				---
Windings resistance at 20°C	R_{12}		Ω				---
Windings inductance	L_{12}		mH				---
Maximum speed	n_{max}		min^{-1}				---
Number of pole pairs	PZ						---
Nominal frequency	f_N		Hz				---
Data of equivalent circuit diagram							
	Windings resistance	R_1	Ω				---
	Rotary field inductance	L_{1-D}	mH				---
Speed measuring system data							
	Number of lines	STR				2048	---
	Counting direction	DIRECT:	pos./neg.			+	---
Mass ^{4) 10)}	m_M		kg				---
Max. Motor temperature (Winding)	T_{max}		$^{\circ}\text{C}$			155	---
Allowed ambient temperature ⁷⁾	T_{um}		$^{\circ}\text{C}$			0 to +40	---
Allowed storage / transport temp.	T_L		$^{\circ}\text{C}$			-20 to +80	---
Max. Installation elevation ⁸⁾			m			1000 meters above sea level	---
Protection category ⁹⁾						IP 65	---
Insulation class						F (per DIN VDE 0530 Section 1)	---
Housing coat						Prime coat black (RAL 9005)	---
<p>1) Housing temperature</p> <p>2) Winding temperature</p> <p>3) Depends on torque needs of application. For standard applications, see n_{max} in selection lists of motor/controller combination. For other applications, use the usable speed achieved with required torque via the speed/torque curve.</p> <p>4) Achievable maximum torque depends on drive controller. Only maximum torque M_{max} listed for a motor/controller combination is binding.</p> <p>5) No holding brake</p> <p>6) with 1000 min^{-1}.</p> <p>7) With deviating ambient temperatures see section 4.1.</p> <p>8) With deviating installation elevations see section 4.1.</p> <p>9) with proper mounting of power and feedback cables.</p> <p>10) No blower unit.</p>							

Fig. 12-4: Technical data MHP112B-035

Designation		Symbol	Unit	Data				
Motor type		MHP112B-058						
Motor overtemperature				$\Delta T_{60} \text{ K}^{1)}$	$\Delta T_{100} \text{ K}^{2)}$	$\Delta T_{60} \text{ K}^{1)}$ and $\Delta T_{100} \text{ K}^{2)}$		
Cooling type				natural convection	natural convection	surface cooled	liquid cooled	
Characteristic motor speed	n_K	min^{-1}	4000	4000	4000	---		
Continuous torque at standstill	M_0	Nm	28.0	31.0	42.0	---		
Continuous current at standstill	$I_{0(\text{eff})}$	A	28.5	32.6	42.8	---		
Rated motor power	P_N	kW	3.4	5.4	10.0	---		
Base speed ³⁾	n_N	min^{-1}	3000	3000	3000	---		
Nominal motor voltage	$U_{N(\text{eff})}$	V	214	219	233	---		
Nominal motor current	$I_{N(\text{eff})}$	A	11.0	18.0	32.4	---		
Nominal motor torque	M_N	Nm	10.8	17.2	31.8	---		
Thermal time constant	T_{th}	min	90	90	40	---		
Theoretical maximum torque ⁴⁾	M_{max}	Nm	102.0					
Peak current	$I_{\text{max}(\text{eff})}$	A	128.3					
Rotor moment of inertia ⁵⁾	J_M	kgm^2	192×10^{-4}					
Torque constant at 20°C	K_{mE}	Nm/A	1.14					
Voltage constant at 20°C ⁶⁾	$K_{E\text{eff}}$	V/1000min ⁻¹	70.0					
Windings resistance at 20°C	R_{12}	Ω	0.17					
Windings inductance	L_{12}	mH	2.2					
Maximum speed	n_{max}	min^{-1}	4500					
Number of pole pairs	PZ		4					
Nominal frequency	f_N	Hz	200					
Data of equivalent circuit diagram								
	Windings resistance	R_1	Ω	0.09				
	Rotary field inductance	L_{1-D}	mH	1.1				
Speed measuring system data								
	Number of lines	STR	2048					
	Counting direction	DIRECT:	pos./neg.	+				
Mass ^{4) 10)}	m_M	kg	48.0					
Max. Motor temperature (Winding)	T_{max}	°C	155					
Allowed ambient temperature ⁷⁾	T_{um}	°C	0 to +40					
Allowed storage / transport temp.	T_L	°C	-20 to +80					
Max. Installation elevation ⁸⁾		m	1000 meters above sea level					
Protection category ⁹⁾			IP 65					
Insulation class			F (per DIN VDE 0530 Section 1)					
Housing coat			Prime coat black (RAL 9005)					
<p>1) Housing temperature</p> <p>2) Winding temperature</p> <p>3) Depends on torque needs of application. For standard applications, see n_{max} in selection lists of motor/controller combination. For other applications, use the usable speed achieved with required torque via the speed/torque curve.</p> <p>4) Achievable maximum torque depends on drive controller. Only maximum torque M_{max} listed for a motor/controller combination is binding.</p> <p>5) No holding brake</p> <p>6) with 1000 min⁻¹.</p> <p>7) With deviating ambient temperatures see section 4.1.</p> <p>8) With deviating installation elevations see section 4.1.</p> <p>9) with proper mounting of power and feedback cables.</p> <p>10) No blower unit.</p>								

Fig. 12-5: Technical data MHP112B-058

Designation		Symbol	Unit	Data				
Motor type		MHP112C-024						
Motor overtemperature				$\Delta T_{60} \text{ K}^{1)}$	$\Delta T_{100} \text{ K}^{2)}$	$\Delta T_{60} \text{ K}^{1)}$ and $\Delta T_{100} \text{ K}^{2)}$		
Cooling type				natural convection	natural convection	surface cooled	liquid cooled	
Characteristic motor speed	n_K	min^{-1}	2000	2000	2000	---		
Continuous torque at standstill	M_0	Nm	38.0	43.5	57.0	---		
Continuous current at standstill	$I_{0(\text{eff})}$	A	18.6	22.0	27.9	---		
Rated motor power	P_N	kW	4.3	7.4	11.5	---		
Base speed ³⁾	n_N	min^{-1}	2500	2500	2500	---		
Nominal motor voltage	$U_{N(\text{eff})}$	V	372	383	403	---		
Nominal motor current	$I_{N(\text{eff})}$	A	8.1	14.3	21.6	---		
Nominal motor torque	M_N	Nm	16.6	28.3	44.1	---		
Thermal time constant	T_{th}	min	90	90	40	---		
Theoretical maximum torque ⁴⁾	M_{max}	Nm	148.0					
Peak current	$I_{\text{max}(\text{eff})}$	A	83.7					
Rotor moment of inertia ⁵⁾	J_M	kgm^2	273×10^{-4}					
Torque constant at 20°C	K_{mE}	Nm/A	2.37					
Voltage constant at 20°C ⁶⁾	$K_{E\text{eff}}$	V/1000min ⁻¹	145.5					
Windings resistance at 20°C	R_{12}	Ω	0.43					
Windings inductance	L_{12}	mH	6.7					
Maximum speed	n_{max}	min^{-1}	4500					
Number of pole pairs	PZ		4					
Nominal frequency	f_N	Hz	167					
Data of equivalent circuit diagram								
	Windings resistance	R_1	Ω	0.22				
	Rotary field inductance	L_{1-D}	mH	3.35				
Speed measuring system data								
	Number of lines	STR	2048					
	Counting direction	DIRECT:	pos./neg.	+				
Mass ^{4) 10)}	m_M	kg	48.0					
Max. Motor temperature (Winding)	T_{max}	°C	155					
Allowed ambient temperature ⁷⁾	T_{um}	°C	0 to +40					
Allowed storage / transport temp.	T_L	°C	-20 to +80					
Max. Installation elevation ⁸⁾		m	1000 meters above sea level					
Protection category ⁹⁾			IP 65					
Insulation class			F (per DIN VDE 0530 Section 1)					
Housing coat			Prime coat black (RAL 9005)					
<p>1) Housing temperature 2) Winding temperature 3) Depends on torque needs of application. For standard applications, see n_{max} in selection lists of motor/controller combination. For other applications, use the usable speed achieved with required torque via the speed/torque curve. 4) Achievable maximum torque depends on drive controller. Only maximum torque M_{max} listed for a motor/controller combination is binding. 5) No holding brake 6) with 1000 min^{-1}. 7) With deviating ambient temperatures see section 4.1. 8) With deviating installation elevations see section 4.1. 9) with proper mounting of power and feedback cables. 10) No blower unit.</p>								

Fig. 12-6: Technical data MHP112C-024

Designation		Symbol	Unit	Data				
Motor type		MHP112C-035						
Motor overtemperature				$\Delta T_{60} \text{ K}^{1)}$	$\Delta T_{100} \text{ K}^{2)}$	$\Delta T_{60} \text{ K}^{1)}$ and $\Delta T_{100} \text{ K}^{2)}$		
Cooling type				natural convection	natural convection	surface cooled	liquid cooled	
Characteristic motor speed	n_K	min^{-1}	3000	3000	3000	---		
Continuous torque at standstill	M_0	Nm	38.0	43.5	57.0	---		
Continuous current at standstill	$I_{0(\text{eff})}$	A	22.6	26.8	33.9	---		
Rated motor power	P_N	kW	4.1	7.2	11.4	---		
Base speed ³⁾	n_N	min^{-1}	2500	2500	2500	---		
Nominal motor voltage	$U_{N(\text{eff})}$	V	303	312	326	---		
Nominal motor current	$I_{N(\text{eff})}$	A	9.4	17.0	26.0	---		
Nominal motor torque	M_N	Nm	15.8	27.6	43.7	---		
Thermal time constant	T_{th}	min	90	90	40	---		
Theoretical maximum torque ⁴⁾	M_{max}	Nm	148.0					
Peak current	$I_{\text{max}(\text{eff})}$	A	101.7					
Rotor moment of inertia ⁵⁾	J_M	kgm^2	273×10^{-4}					
Torque constant at 20°C	K_{mE}	Nm/A	1.95					
Voltage constant at 20°C ⁶⁾	$K_{E\text{eff}}$	$\text{V}/1000\text{min}^{-1}$	119.1					
Windings resistance at 20°C	R_{12}	Ω	0.3					
Windings inductance	L_{12}	mH	4.2					
Maximum speed	n_{max}	min^{-1}	4500					
Number of pole pairs	PZ		4					
Nominal frequency	f_N	Hz	167					
Data of equivalent circuit diagram								
	Windings resistance	R_1	Ω	0.15				
	Rotary field inductance	L_{1-D}	mH	2.1				
Speed measuring system data								
	Number of lines	STR	2048					
	Counting direction	DIRECT:	pos./neg.	+				
Mass ^{4) 10)}	m_M	kg	48,0					
Max. Motor temperature (Winding)	T_{max}	$^{\circ}\text{C}$	155					
Allowed ambient temperature ⁷⁾	T_{um}	$^{\circ}\text{C}$	0 to +40					
Allowed storage / transport temp.	T_L	$^{\circ}\text{C}$	-20 to +80					
Max. Installation elevation ⁸⁾		m	1000 meters above sea level					
Protection category ⁹⁾			IP 65					
Insulation class			F (per DIN VDE 0530 Section 1)					
Housing coat			Prime coat black (RAL 9005)					
<p>1) Housing temperature 2) Winding temperature 3) Depends on torque needs of application. For standard applications, see n_{max} in selection lists of motor/controller combination. For other applications, use the usable speed achieved with required torque via the speed/torque curve. 4) Achievable maximum torque depends on drive controller. Only maximum torque M_{max} listed for a motor/controller combination is binding. 5) No holding brake 6) with 1000 min^{-1}. 7) With deviating ambient temperatures see section 4.1. 8) With deviating installation elevations see section 4.1. 9) with proper mounting of power and feedback cables. 10) No blower unit.</p>								

Fig. 12-7: Technical data MHP112C-035

Designation		Symbol	Unit	Data				
Motor type		MHP112C-058						
Motor overtemperature				$\Delta T_{60} \text{ K}^{1)}$	$\Delta T_{100} \text{ K}^{2)}$	$\Delta T_{60} \text{ K}^{1)}$ and $\Delta T_{100} \text{ K}^{2)}$		
Cooling type				natural convection	natural convection	surface cooled	liquid cooled	
Characteristic motor speed	n_K	min^{-1}	4000	4000	4000	---		
Continuous torque at standstill	M_0	Nm	38.0	43.5	57.0	---		
Continuous current at standstill	$I_{0(\text{eff})}$	A	37.7	44.6	56.6	---		
Rated motor power	P_N	kW	2.0	6.6	10.7	---		
Base speed ³⁾	n_N	min^{-1}	2500	2500	2500	---		
Nominal motor voltage	$U_{N(\text{eff})}$	V	182	188	196	---		
Nominal motor current	$I_{N(\text{eff})}$	A	7.5	25.8	40.4	---		
Nominal motor torque	M_N	Nm	7.6	25.2	40.7	---		
Thermal time constant	T_{th}	min	90	90	40	---		
Theoretical maximum torque ⁴⁾	M_{max}	Nm	148.0					
Peak current	$I_{\text{max}(\text{eff})}$	A	169.7					
Rotor moment of inertia ⁵⁾	J_M	kgm^2	273×10^{-4}					
Torque constant at 20°C	K_{mE}	Nm/A	1.17					
Voltage constant at 20°C ⁶⁾	$K_{E\text{eff}}$	$\text{V}/1000\text{min}^{-1}$	72.2					
Windings resistance at 20°C	R_{12}	Ω	0.12					
Windings inductance	L_{12}	mH	1.5					
Maximum speed	n_{max}	min^{-1}	4500					
Number of pole pairs	PZ		4					
Nominal frequency	f_N	Hz	167					
Data of equivalent circuit diagram								
	Windings resistance	R_1	Ω	0.6				
	Rotary field inductance	L_{1-D}	mH	0.75				
Speed measuring system data								
	Number of lines	STR	2048					
	Counting direction	DIRECT:	pos./neg.	+				
Mass ^{4) 10)}	m_M	kg	48.0					
Max. Motor temperature (Winding)	T_{max}	°C	155					
Allowed ambient temperature ⁷⁾	T_{um}	°C	0 to +40					
Allowed storage / transport temp.	T_L	°C	-20 to +80					
Max. Installation elevation ⁸⁾		m	1000 meters above sea level					
Protection category ⁹⁾			IP 65					
Insulation class			F (per DIN VDE 0530 Section 1)					
Housing coat			Prime coat black (RAL 9005)					
<p>1) Housing temperature 2) Winding temperature 3) Depends on torque needs of application. For standard applications, see n_{max} in selection lists of motor/controller combination. For other applications, use the usable speed achieved with required torque via the speed/torque curve. 4) Achievable maximum torque depends on drive controller. Only maximum torque M_{max} listed for a motor/controller combination is binding. 5) No holding brake 6) with 1000 min^{-1}. 7) With deviating ambient temperatures see section 4.1. 8) With deviating installation elevations see section 4.1. 9) with proper mounting of power and feedback cables. 10) No blower unit.</p>								

Fig. 12-8: Technical data MHP112C-058

Designation		Symbol	Unit	Data				
Motor type		MHP112D-027						
Motor overtemperature				$\Delta T_{60} \text{ K}^{1)}$	$\Delta T_{100} \text{ K}^{2)}$	$\Delta T_{60} \text{ K}^{1)}$ and $\Delta T_{100} \text{ K}^{2)}$		
Cooling type				natural convection	natural convection	surface cooled	liquid cooled	
Characteristic motor speed	n_K	min^{-1}	2000	2000	2000	---		
Continuous torque at standstill	M_0	Nm	48.0	57.0	72.0	---		
Continuous current at standstill	$I_{0(\text{eff})}$	A	22.2	27.3	33.3	---		
Rated motor power	P_N	kW	5.0	8.3	12.0	---		
Base speed ³⁾	n_N	min^{-1}	2000	2000	2000	---		
Nominal motor voltage	$U_{N(\text{eff})}$	V	317	328	342	---		
Nominal motor current	$I_{N(\text{eff})}$	A	11.0	18.9	26.4	---		
Nominal motor torque	M_N	Nm	23.8	39.4	57.1	---		
Thermal time constant	T_{th}	min	90	90	40	---		
Theoretical maximum torque ⁴⁾	M_{max}	Nm	187.0					
Peak current	$I_{\text{max}(\text{eff})}$	A	99.9					
Rotor moment of inertia ⁵⁾	J_M	kgm^2	360×10^{-4}					
Torque constant at 20°C	K_{mE}	Nm/A	2.51					
Voltage constant at 20°C ⁶⁾	$K_{E\text{eff}}$	$\text{V}/1000\text{min}^{-1}$	154.5					
Windings resistance at 20°C	R_{12}	Ω	0.35					
Windings inductance	L_{12}	mH	5.7					
Maximum speed	n_{max}	min^{-1}	3000					
Number of pole pairs	PZ		4					
Nominal frequency	f_N	Hz	133					
Data of equivalent circuit diagram								
	Windings resistance	R_1	Ω	0.18				
	Rotary field inductance	L_{1-D}	mH	2.85				
Speed measuring system data								
	Number of lines	STR	2048					
	Counting direction	DIRECT:	pos./neg.	+				
Mass ^{4) 10)}	m_M	kg	48.0					
Max. Motor temperature (Winding)	T_{max}	$^{\circ}\text{C}$	155					
Allowed ambient temperature ⁷⁾	T_{um}	$^{\circ}\text{C}$	0 to +40					
Allowed storage / transport temp.	T_L	$^{\circ}\text{C}$	-20 to +80					
Max. Installation elevation ⁸⁾		m	1000 meters above sea level					
Protection category ⁹⁾			IP 65					
Insulation class			F (per DIN VDE 0530 Section 1)					
Housing coat			Prime coat black (RAL 9005)					
<p>1) Housing temperature</p> <p>2) Winding temperature</p> <p>3) Depends on torque needs of application. For standard applications, see n_{max} in selection lists of motor/controller combination. For other applications, use the usable speed achieved with required torque via the speed/torque curve.</p> <p>4) Achievable maximum torque depends on drive controller. Only maximum torque M_{max} listed for a motor/controller combination is binding.</p> <p>5) No holding brake</p> <p>6) with 1000 min^{-1}.</p> <p>7) With deviating ambient temperatures see section 4.1.</p> <p>8) With deviating installation elevations see section 4.1.</p> <p>9) with proper mounting of power and feedback cables.</p> <p>10) No blower unit.</p>								

Fig. 12-9: Technical data MHP112D

Designation	Symbol	Unit	Data holding brake	
Motor type			MHP112A MHP112B	MHP112C MHP112D
holding torque	M_H	Nm	22	70
nominal voltage	U_N	V	DC 24 ±10%	DC 24 ±10%
nominal current	I_N	A	0.71	1.29
moment of inertia	J_B	kgm ²	3.6×10^{-4}	30×10^{-4}
separating time	t_1	ms	2.0	53
link time	t_2	ms	50.0	97
Mass	m_B	kg	1.1	3.8

Fig. 12-10: Technical data holding brake (Option)

Desingation	Symbol	Unit	Data surface cooling	
Nominal voltage	U_N	V	1 x AC 230 ±10%	1 x AC 115 ±10%
Nominal current	I_N	A	0.2	0.4
power consumption	S_N	VA	40	39

Fig. 12-11: Technical data surface cooling MHP112 (Option)

12.2 Torque/speed curves

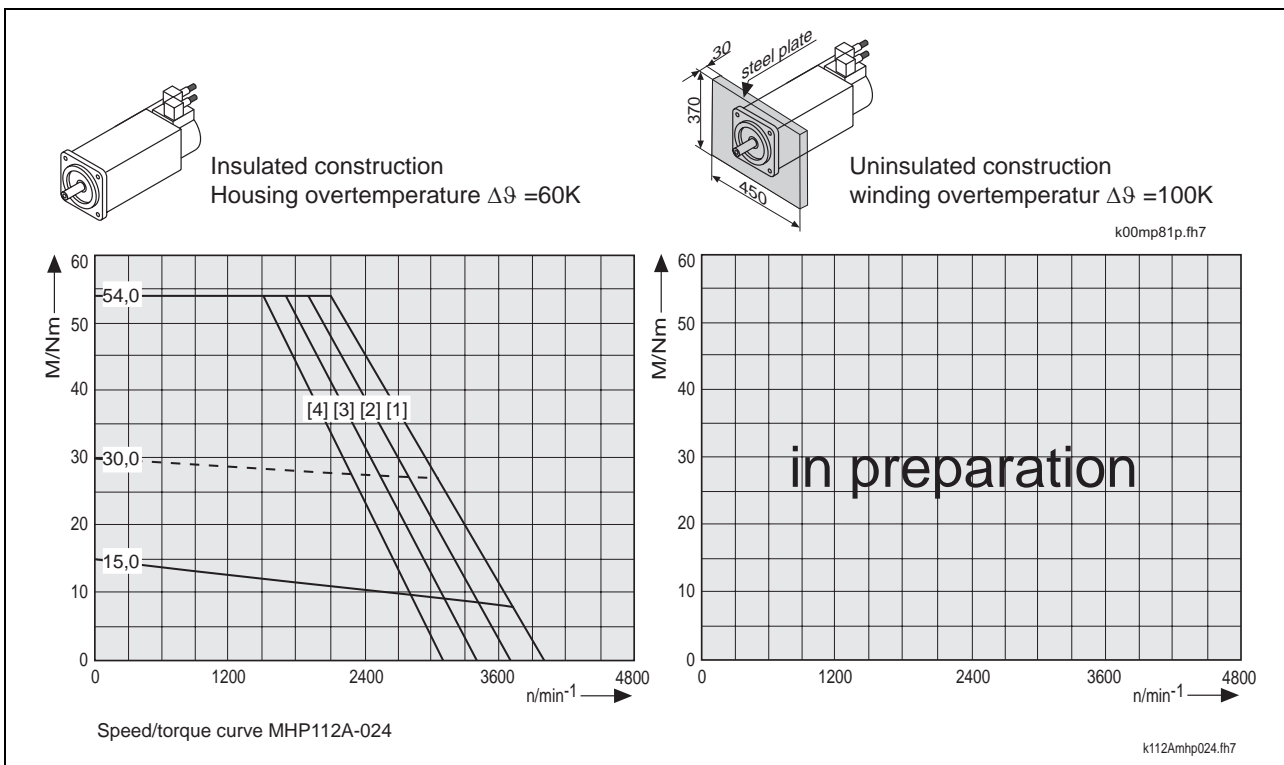
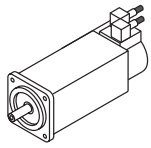
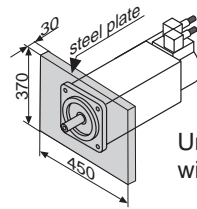

Fig. 12-12: Torque/speed curves



Insulated construction
Housing overtemperature $\Delta\theta = 60K$



Uninsulated construction
winding overtemperature $\Delta\theta = 100K$

k00mp81p.th7

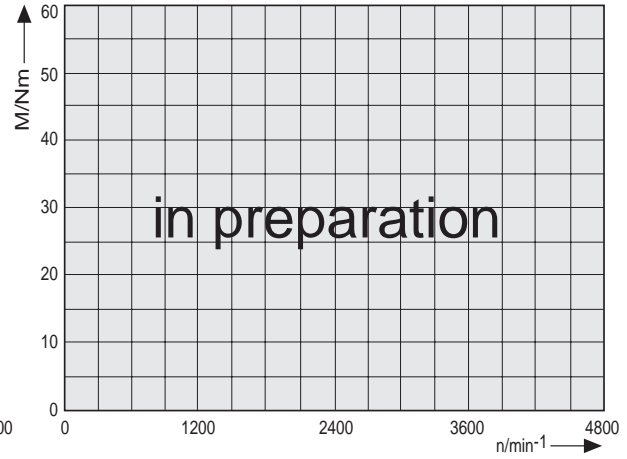
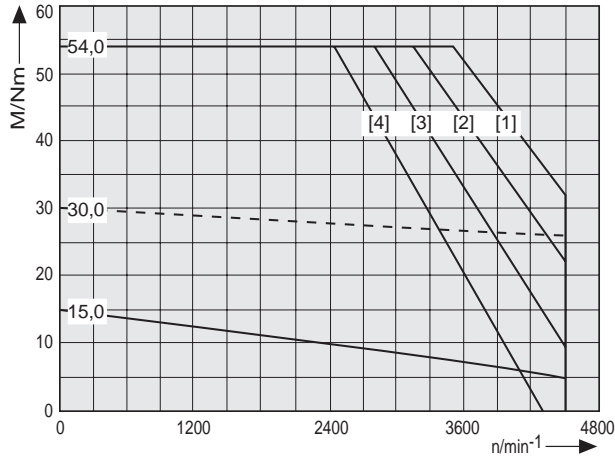

k112Amhp058.th7

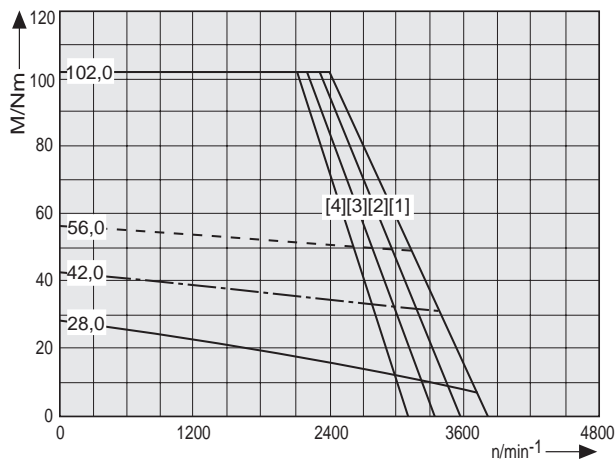

k112Bmhp024.th7

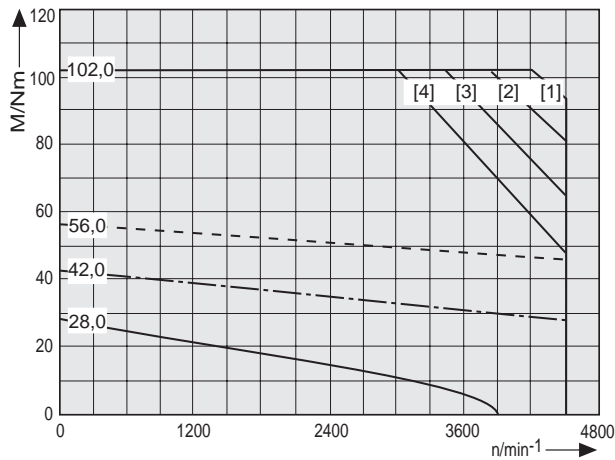

k112Bmhp058.th7

Fig. 12-13: Torque/speed curves

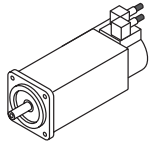

Insulated construction
Housing overtemperature $\Delta\theta = 60\text{K}$

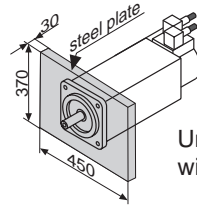

Uninsulated construction
winding overtemperature $\Delta\theta = 100\text{K}$

k00mp81p.fh7

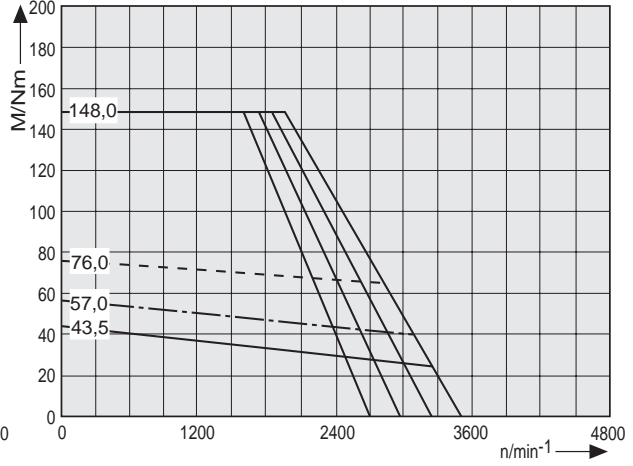
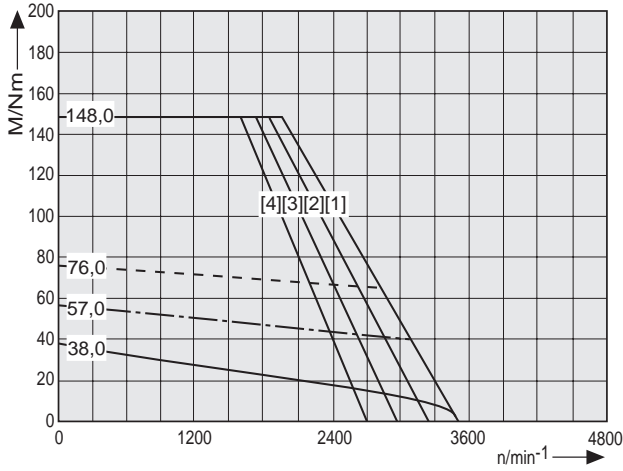

k112Cmhp024.fh7

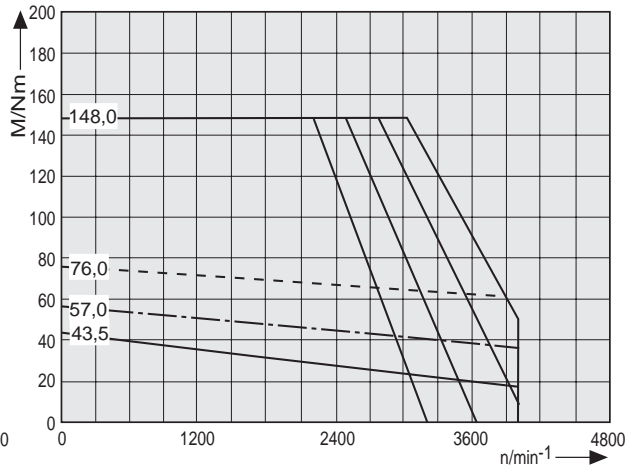
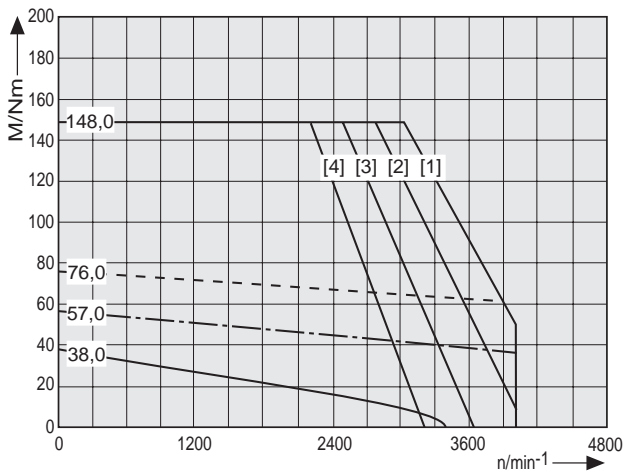

k112Cmhp035.fh7

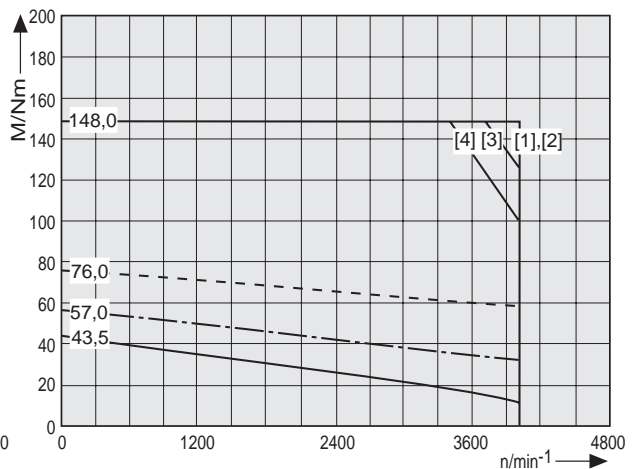
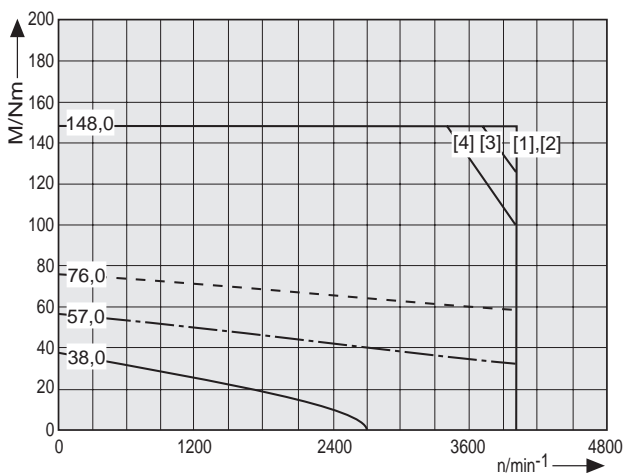

k112Cmhp058.fh7

Fig. 12-14: Torque/speed curves

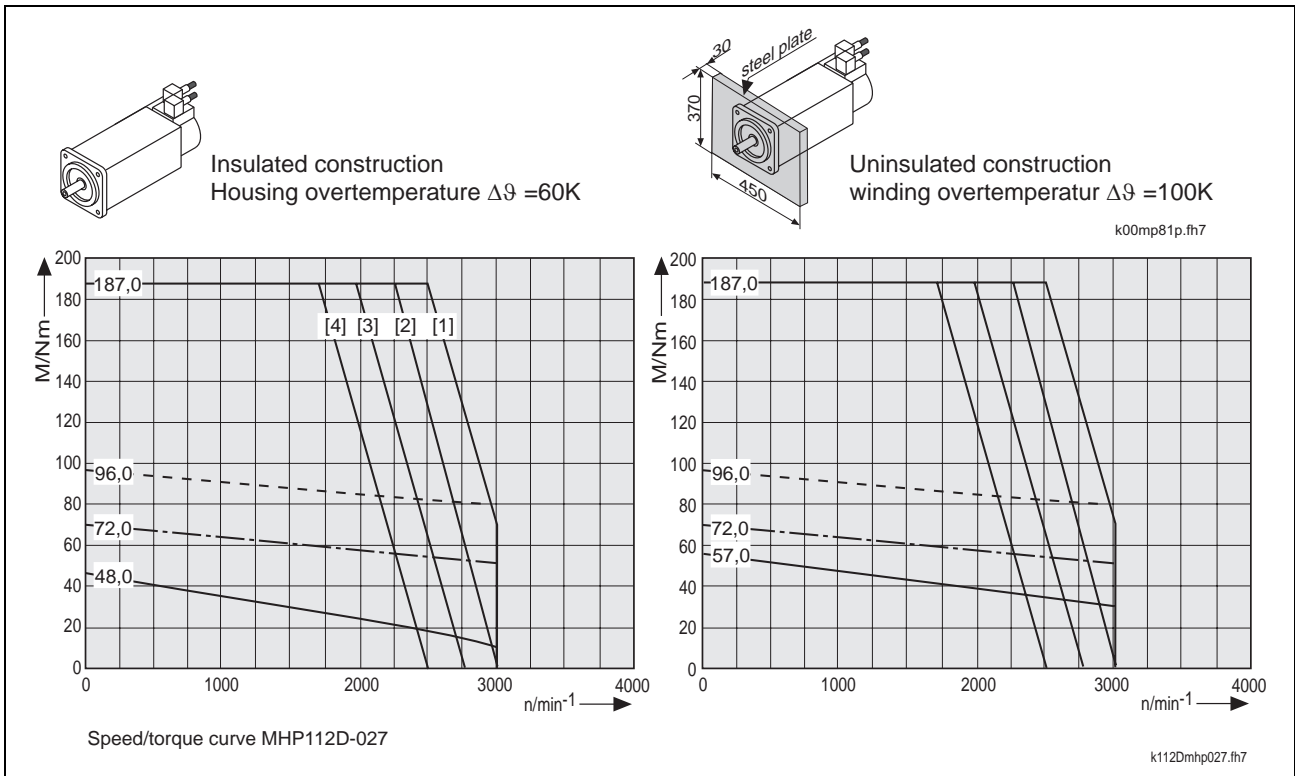

Fig. 12-15: Torque/speed curves

12.3 Maximum Shaft Load

For details see section 4.6 „Shaft load“.

F_{radial_max} and allowed radial force F_{radial} allowed maximum radial force

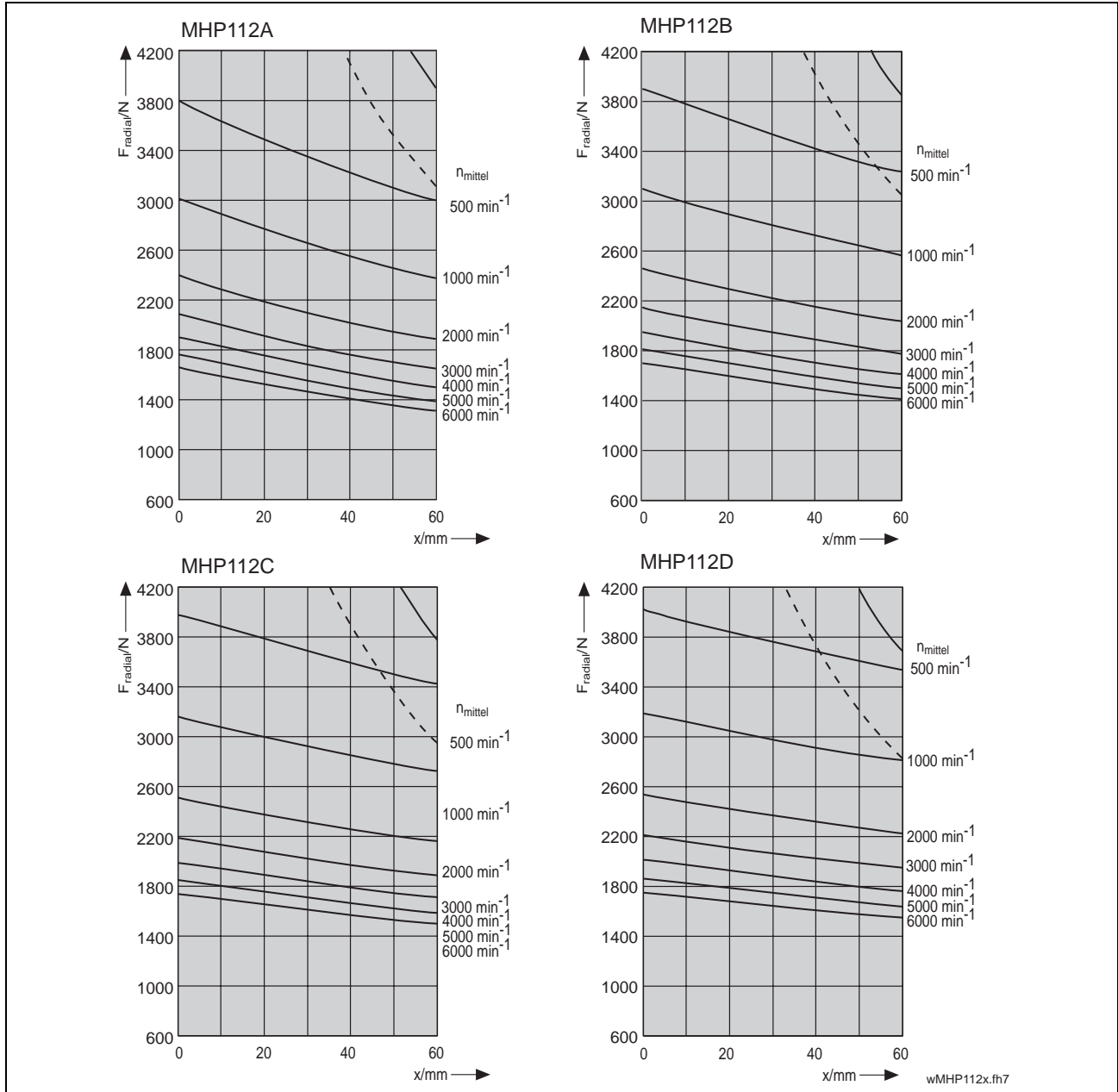

Fig. 12-16: MHP112: Allowed maximum radial force F_{radial_max} and allowed radial force F_{radial}

Allowed axial force F_{axial}

$$F_{axial} = x \cdot F_{radial}$$

x : = 0.36 for MHP112A, MHP112B
 = 0.35 for MHP112C, MHP112D

F_{axial} : Allowed axial force in N

F_{radial} : Allowed radial force in N

Fig. 12-17: MHP112: Allowed axial force F_{axial}

12.4 Dimensional data

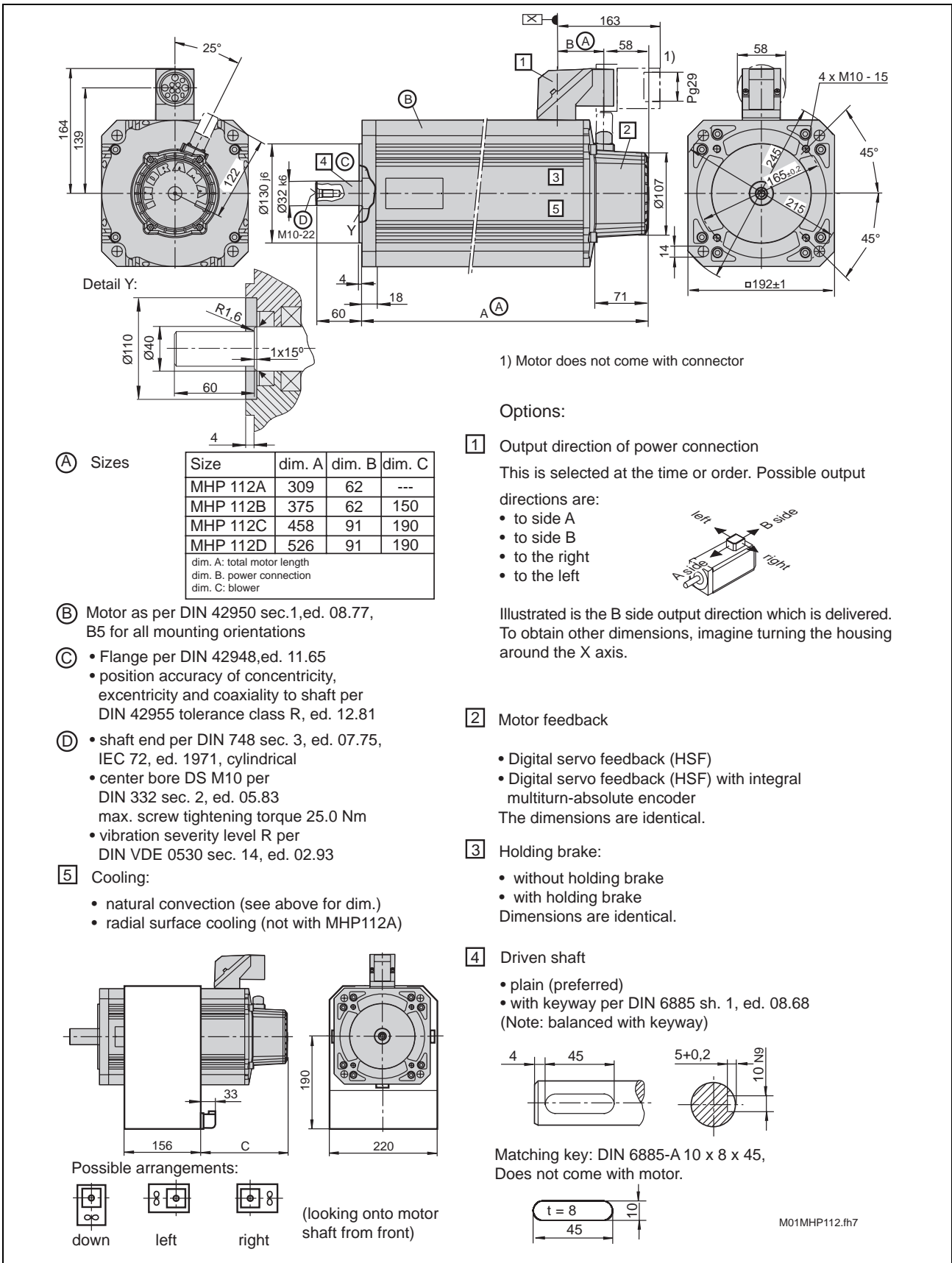

Fig. 12-18: Size sheet MHP112A-024, MHP112B-024, MHP112B-058, MHP112C-024, MHP112C-035, MHP112D-027

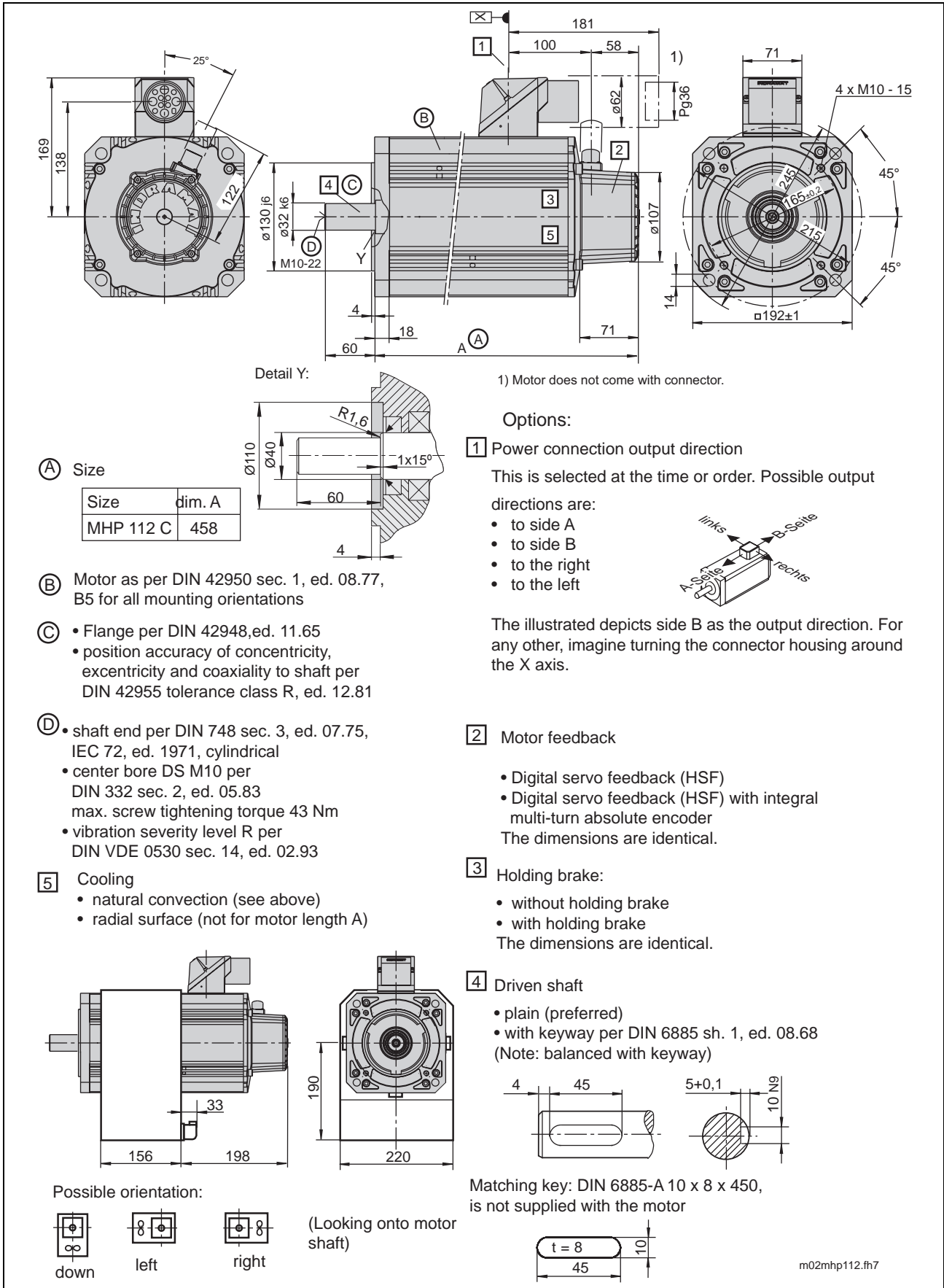

Fig. 12-19: Size sheet MHP112C-058

12.6 Blower Units

Selecting a blower unit

Select a blower unit in the table below.

Motor type	Order designation of blower unit	
	AC 115V / 60Hz	AC 230V / 50Hz
MHP112A-...	---	---
MHP112B-...	LEM –RB112C2XX	LEM –RB112C1XX
MHP112C-...	LEM –RB112C2XX	LEM –RB112C1XX
MHP112D-...	LEM –RB112C2XX	LEM –RB112C1XX
--- blower cannot be mounted		

Fig. 12-21: blower units MHP112

Motor with mounted blower unit

To obtain a motor with mounted surface cooling, list the type designation of the radial blower unit as a subitem of the MHP motor noting the desired arrangement of the blower.

Order position	Designation
1	1 St. Digital AC motor MHP112B-024-NG0-BN
1.1	1 St. Blower unit LEM –RB112C2XX mounted to pos. 1 blower on left

Fig. 12-22: Order data for an MHP motor with mounted blower unit

Motor with separate blower unit

If the blower is listed as a separate item, then it will be desired as such, i.e., not mounted.

Order position	Designation
1	1 St. Digital AC motor MHP112B-024-NG0-BN
2	1 St. Blower unit LEM –RB112C2XX

Fig. 12-23: Order data for an MHP motor with separate blower unit

13 MHP115

13.1 Technical data

Designation	Symbol	Unit	Data			
Motor type	MHP115A-024					
Motor overtemperature			$\Delta T_{60} \text{ K}^{1)}$	$\Delta T_{100} \text{ K}^{2)}$	$\Delta T_{60} \text{ K}^{1)}$ and $\Delta T_{100} \text{ K}^{2)}$	
Cooling type			natural convection	natural convection	surface cooling liquid cooling	
Characteristic motor speed	n_K	min^{-1}	2000		---	
Continuous torque at standstill	M_0	Nm	32.0		60.8	
Continuous current at standstill	$I_{0(\text{eff})}$	A	14.4		27.4	
Rated motor power	P_N	kW	3.1		11.8	
Base speed ³⁾	n_N	min^{-1}	2000		2000	
Nominal motor voltage	$U_{N(\text{eff})}$	V	308	in prep.	366	
Nominal motor current	$I_{N(\text{eff})}$	A	6.7		25.3	
Nominal motor torque	M_N	Nm	14.9		56.2	
Thermal time constant	T_{th}	min	60		20	
Theoretical maximum torque ⁴⁾	M_{max}	Nm	110.0			
Peak current	$I_{\text{max}(\text{eff})}$	A	64.8			
Rotor moment of inertia ⁵⁾	J_M	kgm^2	65.0×10^{-4}			
Torque constant at 20°C	K_{mE}	Nm/A	2.44			
Voltage constant at 20°C ⁶⁾	$K_{E\text{eff}}$	$\text{V}/1000\text{min}^{-1}$	150.0			
Windings resistance at 20°C	R_{12}	Ω	0.66			
Windings inductance	L_{12}	mH	8.6			
Maximum speed	n_{max}	min^{-1}	6000			
Number of pole pairs	PZ		4			
Nominal frequency	f_N	Hz	133			
Data of equivalent circuit diagram						
windings resistance	R_1	Ω	0.33			
rotary field inductance	L_{1-D}	mH	4.3			
Speed measuring system data						
number of lines	STR		2048			
counting direction	DIRECT:	pos./neg.	+			
Mass ^{4) 10)}	m_M	kg	30.0			
Max. Motor temperature (Winding)	T_{max}	°C	155			
Allowed ambient temperature ⁷⁾	T_{um}	°C	0 to +40			
Allowed storage / transport temp.	T_L	°C	-20 to +80			
Max. Installation elevation ⁸⁾		m	1000 meters above sea level			
Protection category ⁹⁾			IP 65			
Insulation class			F (per DIN VDE 0530 section 1)			
Housing coat			prime coat black (RAL 9005)			
1) Housing temperature 2) Winding temperature 3) Depends on torque needs of application. For standard applications, see n_{max} in selection lists of motor/controller combination. For other applications, use the usable speed achieved with required torque via the speed/torque curve. 4) Achievable maximum torque depends on drive controller. Only maximum torque M_{max} listed for a motor/controller combination is binding. 5) No holding brake 6) with 1000 min^{-1} . 7) With deviating ambient temperatures see section 4.1. 8) With deviating installation elevations see section 4.1. 9) with proper mounting of power and feedback cables. 10) No blower unit.						

Fig. 13-1: Technical data MHP115A-024

Designation		Symbol	Unit	Data		
Motor type		MHP115A-058				
Motor overtemperature				$\Delta T_{60} \text{ K}^{1)}$	$\Delta T_{100} \text{ K}^{2)}$	$\Delta T_{60} \text{ K}^{1)}$ and $\Delta T_{100} \text{ K}^{2)}$
Cooling type				natural convection	natural convection	surface cooling liquid cooling
Characteristic motor speed	n_K	min^{-1}	4000		---	4000
Continuous torque at standstill	M_0	Nm	32.0		---	60.8
Continuous current at standstill	$I_{0(\text{eff})}$	A	24.3		---	46.2
Rated motor power	P_N	kW	1.5		---	11.3
Base speed ³⁾	n_N	min^{-1}	2000		---	2000
Nominal motor voltage	$U_{N(\text{eff})}$	V	180	in prep.	---	211
Nominal motor current	$I_{N(\text{eff})}$	A	5.4		---	41.0
Nominal motor torque	M_N	Nm	7.1		---	53.9
Thermal time constant	T_{th}	min	60		---	20
Theoretical maximum torque ⁴⁾	M_{max}	Nm				110.0
Peak current	$I_{\text{max}(\text{eff})}$	A			64.8	
Rotor moment of inertia ⁵⁾	J_M	kgm^2			65.0×10^{-4}	
Torque constant at 20°C	K_{mE}	Nm/A			1.45	
Voltage constant at 20°C ⁶⁾	$K_{E\text{eff}}$	V/1000min ⁻¹			89.1	
Windings resistance at 20°C	R_{12}	Ω			0.21	
Windings inductance	L_{12}	mH			2.88	
Maximum speed	n_{max}	min^{-1}			6000	
Number of pole pairs	PZ				4	
Nominal frequency	f_N	Hz			133	
Data of equivalent circuit diagram						
	windings resistance	R_1	Ω			0.11
	rotary field inductance	L_{1-D}	mH			1.44
Speed measuring system data						
	number of lines	STR				2048
	counting direction	DIRECT:	pos./neg.			+
Mass ^{4) 10)}	m_M	kg				30.0
Max. Motor temperature (Winding)	T_{max}	°C				155
Allowed ambient temperature ⁷⁾	T_{um}	°C				0 to +40
Allowed storage / transport temp.	T_L	°C				-20 to +80
Max. Installation elevation ⁸⁾		m				1000 meters above sea level
Protection category ⁹⁾						IP 65
Insulation class						F (per DIN VDE 0530 section 1)
Housing coat						prime coat black (RAL 9005)
<p>1) Housing temperature</p> <p>2) Winding temperature</p> <p>3) Depends on torque needs of application. For standard applications, see n_{max} in selection lists of motor/controller combination. For other applications, use the usable speed achieved with required torque via the speed/torque curve.</p> <p>4) Achievable maximum torque depends on drive controller. Only maximum torque M_{max} listed for a motor/controller combination is binding.</p> <p>5) No holding brake</p> <p>6) with 1000 min^{-1}.</p> <p>7) With deviating ambient temperatures see section 4.1.</p> <p>8) With deviating installation elevations see section 4.1.</p> <p>9) with proper mounting of power and feedback cables.</p> <p>10) No blower unit.</p>						

Fig. 13-2: Technical data MHP115A-058

Designation		Symbol	Unit	Data		
Motor type		MHP115B-024				
Motor overtemperature				$\Delta T_{60} \text{ K}^{1)}$	$\Delta T_{100} \text{ K}^{2)}$	$\Delta T_{60} \text{ K}^{1)}$ and $\Delta T_{100} \text{ K}^{2)}$
Cooling type				natural convection	natural convection	surface cooling liquid cooling
Characteristic motor speed	n_K	min^{-1}	2000		2000	2000
Continuous torque at standstill	M_0	Nm	50.0		75.0	95.0
Continuous current at standstill	$I_{0(\text{eff})}$	A	22.0		33.0	41.8
Rated motor power	P_N	kW	3.7		11.7	18.0
Base speed ³⁾	n_N	min^{-1}	2000		2000	2000
Nominal motor voltage	$U_{N(\text{eff})}$	V	313	in prep.	335	363
Nominal motor current	$I_{N(\text{eff})}$	A	7.9		24.7	37.8
Nominal motor torque	M_N	Nm	17.9		56.1	86.0
Thermal time constant	T_{th}	min	100		45	30
Theoretical maximum torque ⁴⁾	M_{max}	Nm	160.0			
Peak current	$I_{\text{max}(\text{eff})}$	A	99.0			
Rotor moment of inertia ⁵⁾	J_M	kgm^2	93.2×10^{-4}			
Torque constant at 20°C	K_{mE}	Nm/A	2.50			
Voltage constant at 20°C ⁶⁾	$K_{E\text{eff}}$	$\text{V}/1000\text{min}^{-1}$	154.0			
Windings resistance at 20°C	R_{12}	Ω	0.36			
Windings inductance	L_{12}	mH	5.3			
Maximum speed	n_{max}	min^{-1}	6000			
Number of pole pairs	PZ		4			
Nominal frequency	f_N	Hz	133			
Data of equivalent circuit diagram						
	windings resistance	R_1	Ω	0.18		
	rotary field inductance	L_{1-D}	mH	2.65		
Speed measuring system data						
	number of lines	STR	2048			
	counting direction	DIRECT:	pos./neg.	+		
Mass ^{4) 10)}	m_M	kg	40.0			
Max. Motor temperature (Winding)	T_{max}	°C	155			
Allowed ambient temperature ⁷⁾	T_{um}	°C	0 to +40			
Allowed storage / transport temp.	T_L	°C	-20 to +80			
Max. Installation elevation ⁸⁾		m	1000 meters above sea level			
Protection category ⁹⁾			IP 65			
Insulation class			F (per DIN VDE 0530 section 1)			
Housing coat			prime coat black (RAL 9005)			
1) Housing temperature 2) Winding temperature 3) Depends on torque needs of application. For standard applications, see n_{max} in selection lists of motor/controller combination. For other applications, use the usable speed achieved with required torque via the speed/torque curve. 4) Achievable maximum torque depends on drive controller. Only maximum torque M_{max} listed for a motor/controller combination is binding. 5) No holding brake 6) with 1000 min^{-1} . 7) With deviating ambient temperatures see section 4.1. 8) With deviating installation elevations see section 4.1. 9) with proper mounting of power and feedback cables. 10) No blower unit.						

Fig. 13-3: Technical data MHP115B-024

Designation		Symbol	Unit	Data		
Motor type		MHP115B-058				
Motor overtemperature				$\Delta T_{60} \text{ K}^{1)}$	$\Delta T_{100} \text{ K}^{2)}$	$\Delta T_{60} \text{ K}^{1)}$ and $\Delta T_{100} \text{ K}^{2)}$
Cooling type				natural convection	natural convection	surface cooling liquid cooling
Characteristic motor speed	n_K	min^{-1}	4000		4000	4000
Continuous torque at standstill	M_0	Nm	50.0		75.0	95.0
Continuous current at standstill	$I_{0(\text{eff})}$	A	41.4		62.1	78.7
Rated motor power	P_N	kW	2.7		8.7	13.5
Base speed ³⁾	n_N	min^{-1}	1500		1500	1500
Nominal motor voltage	$U_{N(\text{eff})}$	V	125	in prep.	136	149
Nominal motor current	$I_{N(\text{eff})}$	A	14.0		46.1	71.0
Nominal motor torque	M_N	Nm	16.9		55.7	85.7
Thermal time constant	T_{th}	min	100		45	30
Theoretical maximum torque ⁴⁾	M_{max}	Nm	160.0			
Peak current	$I_{\text{max}(\text{eff})}$	A	186.3			
Rotor moment of inertia ⁵⁾	J_M	kgm^2	93.2×10^{-4}			
Torque constant at 20°C	K_{mE}	Nm/A	1.33			
Voltage constant at 20°C ⁶⁾	$K_{E\text{eff}}$	V/1000min ⁻¹	81.8			
Windings resistance at 20°C	R_{12}	Ω	0.11			
Windings inductance	L_{12}	mH	1.6			
Maximum speed	n_{max}	min^{-1}	6000			
Number of pole pairs	PZ		4			
Nominal frequency	f_N	Hz	100			
Data of equivalent circuit diagram						
	windings resistance	R_1	Ω	0.06		
	rotary field inductance	L_{1-D}	mH	0.8		
Speed measuring system data						
	number of lines	STR	2048			
	counting direction	DIRECT:	pos./neg.	+		
Mass ^{4) 10)}	m_M	kg	40.0			
Max. Motor temperature (Winding)	T_{max}	°C	155			
Allowed ambient temperature ⁷⁾	T_{um}	°C	0 to +40			
Allowed storage / transport temp.	T_L	°C	-20 to +80			
Max. Installation elevation ⁸⁾		m	1000 meters above sea level			
Protection category ⁹⁾			IP 65			
Insulation class			F (per DIN VDE 0530 section 1)			
Housing coat			prime coat black (RAL 9005)			
<p>1) Housing temperature 2) Winding temperature 3) Depends on torque needs of application. For standard applications, see n_{max} in selection lists of motor/controller combination. For other applications, use the usable speed achieved with required torque via the speed/torque curve. 4) Achievable maximum torque depends on drive controller. Only maximum torque M_{max} listed for a motor/controller combination is binding. 5) No holding brake 6) with 1000 min⁻¹. 7) With deviating ambient temperatures see section 4.1. 8) With deviating installation elevations see section 4.1. 9) with proper mounting of power and feedback cables. 10) No blower unit.</p>						

Fig. 13-4: Technical data MHP115B-058

Desgination		Symbol	Unit	Data		
Motor type		MHP115C-024				
Motor overtemperature				$\Delta T_{60} \text{ K}^{1)}$	$\Delta T_{100} \text{ K}^{2)}$	$\Delta T_{60} \text{ K}^{1)}$ and $\Delta T_{100} \text{ K}^{2)}$
Cooling type				natural convection	natural convection	surface cooling liquid cooling
Characteristic motor speed	n_K	min^{-1}	2000		2000	2000
Continuous torque at standstill	M_0	Nm	70.0		105.0	133.0
Continuous current at standstill	$I_{0(\text{eff})}$	A	31.6		47.4	60.0
Rated motor power	P_N	kW	3.4		12.1	18.8
Base speed ³⁾	n_N	min^{-1}	1500		1500	1500
Nominal motor voltage	$U_{N(\text{eff})}$	V	228	in prep.	241	256
Nominal motor current	$I_{N(\text{eff})}$	A	9.7		34.9	53.9
Nominal motor torque	M_N	Nm	21.5		77.2	119.4
Thermal time constant	T_{th}	min	100		45	30
Theoretical maximum torque ⁴⁾	M_{max}	Nm	231.0			
Peak current	$I_{\text{max}(\text{eff})}$	A	142.2			
Rotor moment of inertia ⁵⁾	J_M	kgm^2	138.0×10^{-4}			
Torque constant at 20°C	K_{mE}	Nm/A	2.44			
Voltage constant at 20°C ⁶⁾	$K_{E\text{eff}}$	V/1000min ⁻¹	150.0			
Windings resistance at 20°C	R_{12}	Ω	0.185			
Windings inductance	L_{12}	mH	3.0			
Maximum speed	n_{max}	min^{-1}	6000			
Number of pole pairs	PZ		4			
Nominal frequency	f_N	Hz	100			
Data of equivalent circuit diagram						
	windings resistance	R_1	Ω	0.093		
	rotary field inductance	L_{1-D}	mH	1.5		
Speed measuring system data						
	number of lines	STR	2048			
	counting direction	DIRECT:	pos./neg.	+		
Mass ^{4) 10)}	m_M	kg	55.0			
Max. Motor temperature (Winding)	T_{max}	°C	155			
Allowed ambient temperature ⁷⁾	T_{um}	°C	0 to +40			
Allowed storage / transport temp.	T_L	°C	-20 to +80			
Max. Installation elevation ⁸⁾		m	1000 meters above sea level			
Protection category ⁹⁾			IP 65			
Insulation class			F (per DIN VDE 0530 section 1)			
Housing coat			prime coat black (RAL 9005)			
<p>1) Housing temperature 2) Winding temperature 3) Depends on torque needs of application. For standard applications, see n_{max} in selection lists of motor/controller combination. For other applications, use the usable speed achieved with required torque via the speed/torque curve. 4) Achievable maximum torque depends on drive controller. Only maximum torque M_{max} listed for a motor/controller combination is binding. 5) No holding brake 6) with 1000 min^{-1}. 7) With deviating ambient temperatures see section 4.1. 8) With deviating installation elevations see section 4.1. 9) with proper mounting of power and feedback cables. 10) No blower unit.</p>						

Fig. 13-5: Technical data MHP115C-024

Designation		Symbol	Unit	Data		
Motor type		MHP115C-058				
Motor overtemperature				$\Delta T_{60} \text{ K}^{1)}$	$\Delta T_{100} \text{ K}^{2)}$	$\Delta T_{60} \text{ K}^{1)}$ and $\Delta T_{100} \text{ K}^{2)}$
Cooling type				natural convection	natural convection	surface cooling liquid cooling
Characteristic motor speed	n_K	min^{-1}	4000		4000	4000
Continuous torque at standstill	M_0	Nm	70.0		105.0	133.0
Continuous current at standstill	$I_{0(\text{eff})}$	A	54.6		81.9	103.7
Rated motor power	P_N	kW	2.0		8.0	12.4
Base speed ³⁾	n_N	min^{-1}	1000		1000	1000
Nominal motor voltage	$U_{N(\text{eff})}$	V	88	in prep.	93	98
Nominal motor current	$I_{N(\text{eff})}$	A	14.9		59.5	92.6
Nominal motor torque	M_N	Nm	19.1		76.3	118.8
Thermal time constant	T_{th}	min	100		45	30
Theoretical maximum torque ⁴⁾	M_{max}	Nm	231.0			
Peak current	$I_{\text{max}(\text{eff})}$	A	245.7			
Rotor moment of inertia ⁵⁾	J_M	kgm^2	138.0×10^{-4}			
Torque constant at 20°C	K_{mE}	Nm/A	1.41			
Voltage constant at 20°C ⁶⁾	$K_{E\text{eff}}$	V/1000min ⁻¹	86.4			
Windings resistance at 20°C	R_{12}	Ω	0.06			
Windings inductance	L_{12}	mH	0.9			
Maximum speed	n_{max}	min^{-1}	6000			
Number of pole pairs	PZ		4			
Nominal frequency	f_N	Hz	67			
Data of equivalent circuit diagram						
	windings resistance	R_1	Ω	0.03		
	rotary field inductance	$L_1\text{-D}$	mH	0.45		
Speed measuring system data						
	number of lines	STR	2048			
	counting direction	DIRECT:	pos./neg.	+		
Mass ^{4) 10)}	m_M	kg	55.0			
Max. Motor temperature (Winding)	T_{max}	°C	155			
Allowed ambient temperature ⁷⁾	T_{um}	°C	0 to +40			
Allowed storage / transport temp.	T_L	°C	-20 to +80			
Max. Installation elevation ⁸⁾		m	1000 meters above sea level			
Protection category ⁹⁾			IP 65			
Insulation class			F (per DIN VDE 0530 section 1)			
Housing coat			prime coat black (RAL 9005)			
<p>1) Housing temperature 2) Winding temperature 3) Depends on torque needs of application. For standard applications, see n_{max} in selection lists of motor/controller combination. For other applications, use the usable speed achieved with required torque via the speed/torque curve. 4) Achievable maximum torque depends on drive controller. Only maximum torque M_{max} listed for a motor/controller combination is binding. 5) No holding brake 6) with 1000 min^{-1}. 7) With deviating ambient temperatures see section 4.1. 8) With deviating installation elevations see section 4.1. 9) with proper mounting of power and feedback cables. 10) No blower unit.</p>						

Fig. 13-6: Technical data MHP115C-058

Designation	Symbol	Unit	Data holding brake
Motor type			MHP115A MHP115B MHP115C
holding torque	M_H	Nm	70
nominal voltage	U_N	V	DC 24 ±10%
nominal current	I_N	A	1.29
moment of inertia	J_B	kgm ²	30×10^{-4}
separating time	t_1	ms	53
link time	t_2	ms	97
Mass	m_B	kg	3.8

Fig. 13-7: Technical data holding brake MHP115 (Option)

Designation	Symbol	Unit	Data		
Motor type			MHP115A	MHP115B	MHP115C
Nominal power loss	P_{vN}	W	1100	1200	1300
Coolant entry temperature ¹⁾	ϑ_{ein}	°C	+10 ... +40		
Coolant temperature increase at P_{vN}	$\Delta\vartheta_N$	°C	10		
Minimum required coolant flow through at $\Delta\vartheta_N$ ²⁾	Q_N	l/min	1.5	1.7	1.8
Pressure drop at Q_N ²⁾³⁾	Δp_N	bar	0.8	0.9	1.0
Maximum system pressure	p_{max}	bar	3.0		
Volume of coolant channel	V	l	0.09	0.11	0.14
1) Note relationship between coolant temperature at entry and actual ambient temperature: coolant entry temp. may not drop more than 5°C under actual ambient temperature (otherwise danger of condensation)! 2) with water as coolant 3) for deviating flow through values, see flow through diagram in section 6.					

Fig. 13-8: Technical data liquid cooling in MHP115

Designation	Symbol	Unit	Data surface cooling	
nominal voltage	U_N	V	1 x AC 230 ±10%	1 x AC 115 ±10%
nominal current	I_N	A	0.2	0.4
power consumption	S_N	VA	40	39
frequency	f	Hz	50	60

Fig. 13-9: Technical data surface cooling MHP115 (Option)

13.2 Torque/speed curves

See next page.

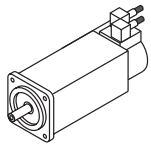

Insulated construction
Housing overtemperature $\Delta\theta = 60K$

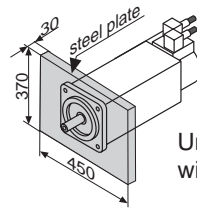

Uninsulated construction
winding overtemperature $\Delta\theta = 100K$

k00mp81p.fh7

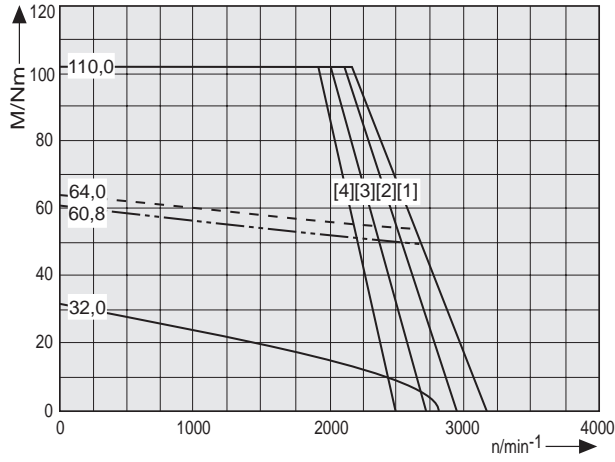

Speed/torque curve MHP115A-024

k115Amhp024.fh7

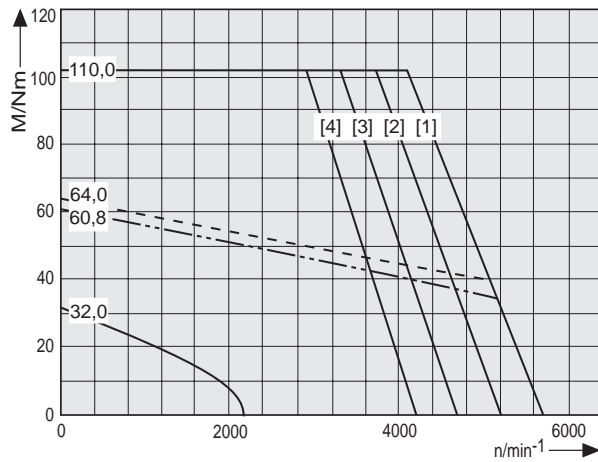
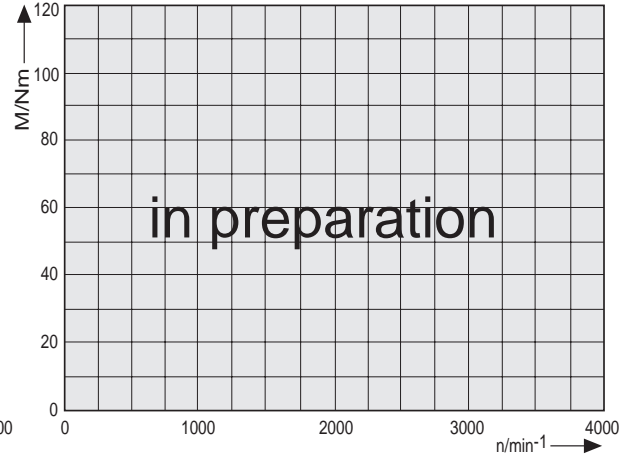

Speed/torque curve MHP115A-058

k115Amhp058.fh7

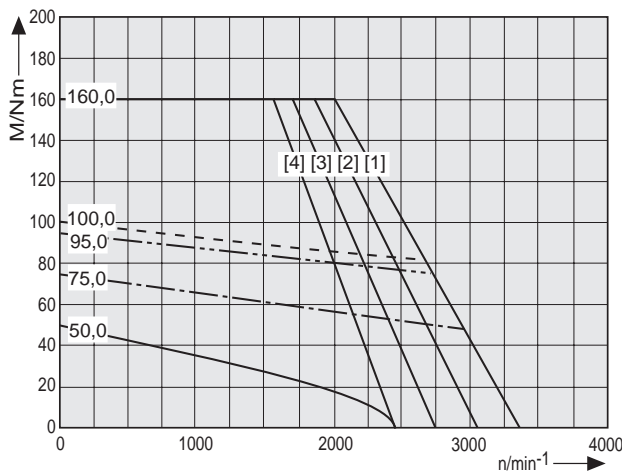
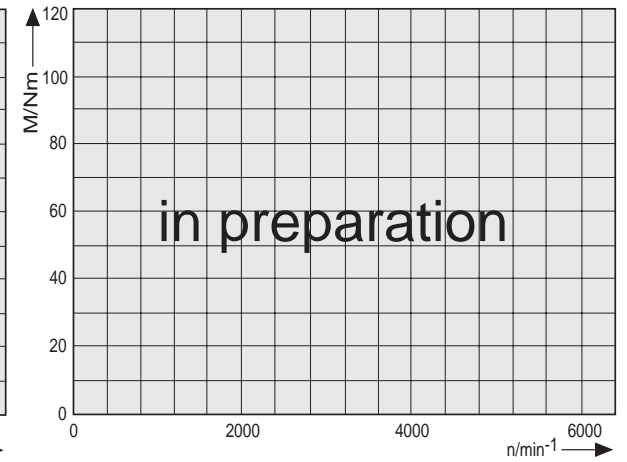

Speed/torque curves MHP115B-024

k115Bmhp024.fh7

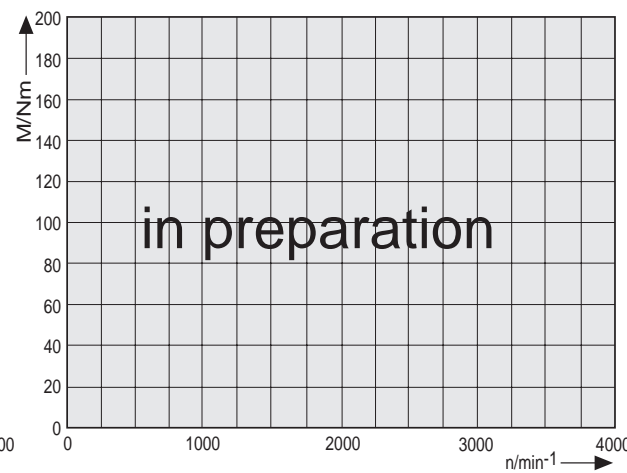
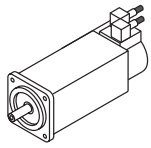
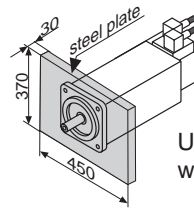

Fig. 13-10: Torque/speed curves



Insulated construction
Housing overtemperature $\Delta\theta = 60K$



Uninsulated construction
winding overtemperature $\Delta\theta = 100K$

k00mp81p.fh7

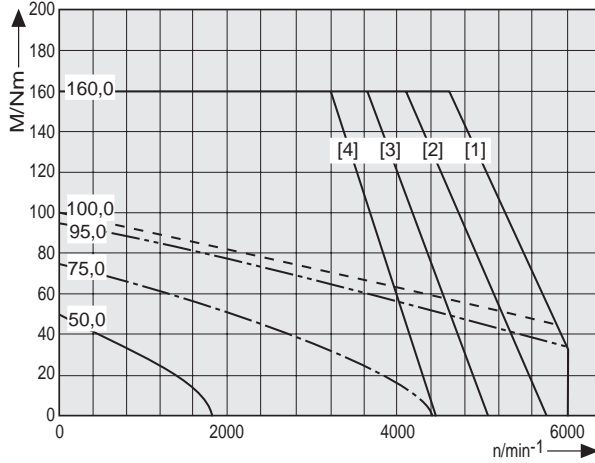

Speed/torque curve MHP115B-058

k115Bmhp058.fh7

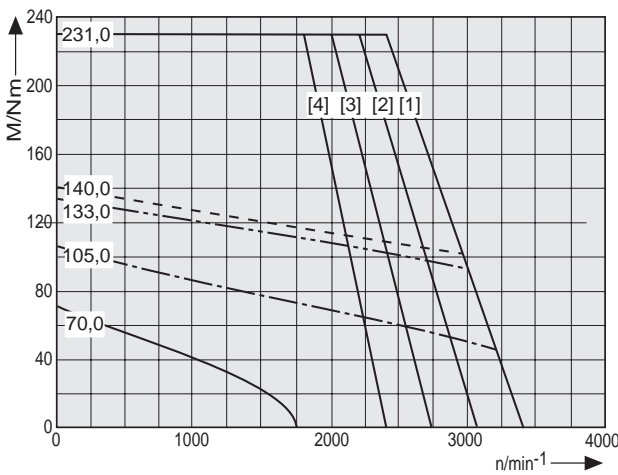
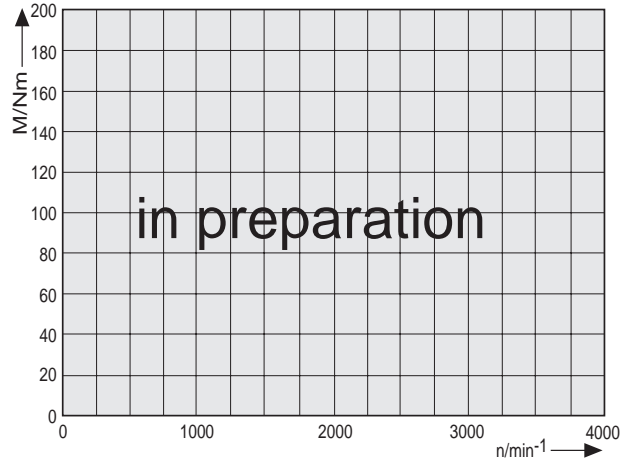

Speed/torque curve MHP115C-024

k115Cmhp024.fh7

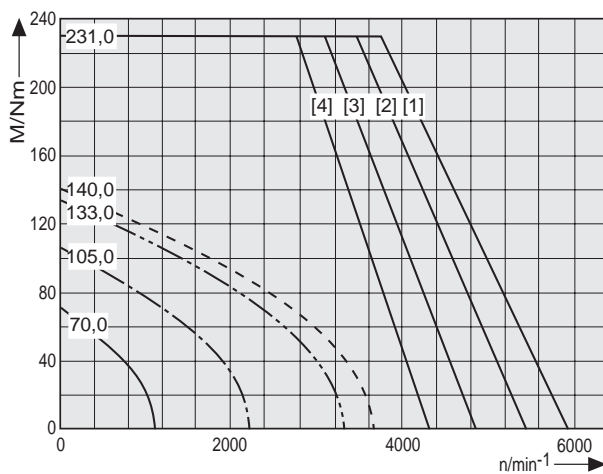
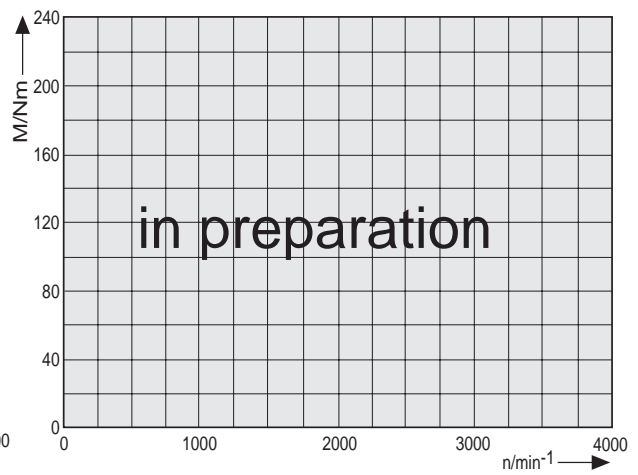

Speed/torque curve MHP115C-058

k115Cmhp058.fh7

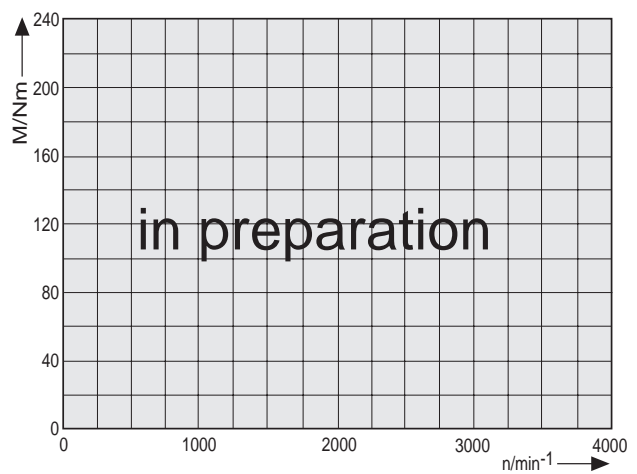

Fig. 13-11: Torque/speed curves

13.3 Maximum Shaft Load

Allowed maximum radial force $F_{\text{radial_max}}$ and allowed radial force F_{radial} For details see section 4.6 „Shaft load“.

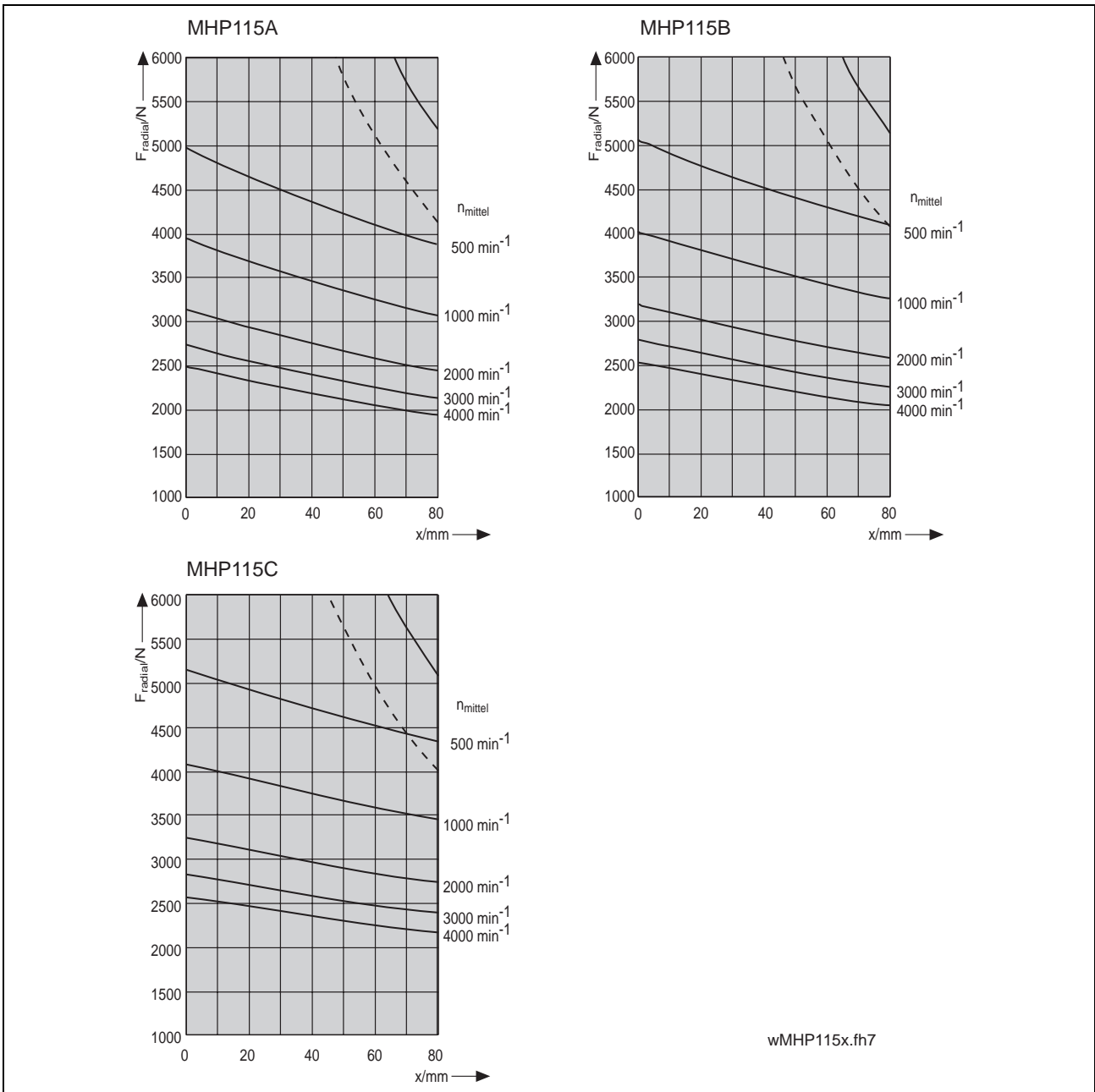

Fig. 13-12: MHP115: allowed maximum radial force $F_{\text{radial_max}}$ and allowed radial force F_{radial}

Allowed axial force F_{axial}

$$F_{\text{axial}} = 0,26 \cdot F_{\text{radial}}$$

F_{axial} : allowed axial force in N
 F_{radial} : allowed radial force in N

Fig. 13-13: MHP115: allowed axial force F_{axial}

13.4 Dimensional data (Standard cooling)

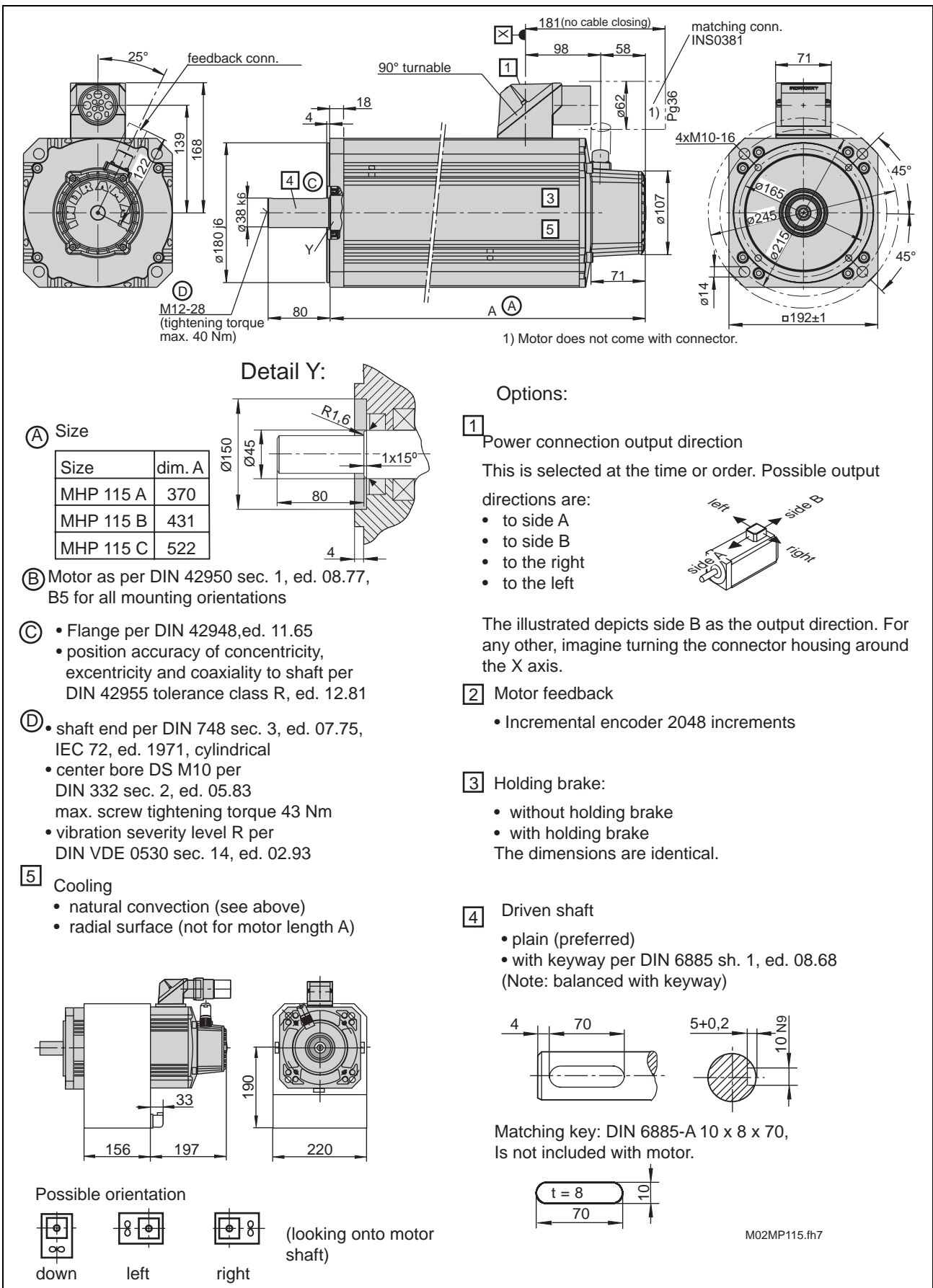

Fig. 13-14: Size sheet MHP115.-...-N

13.5 Dimensional data (Liquid cooling)

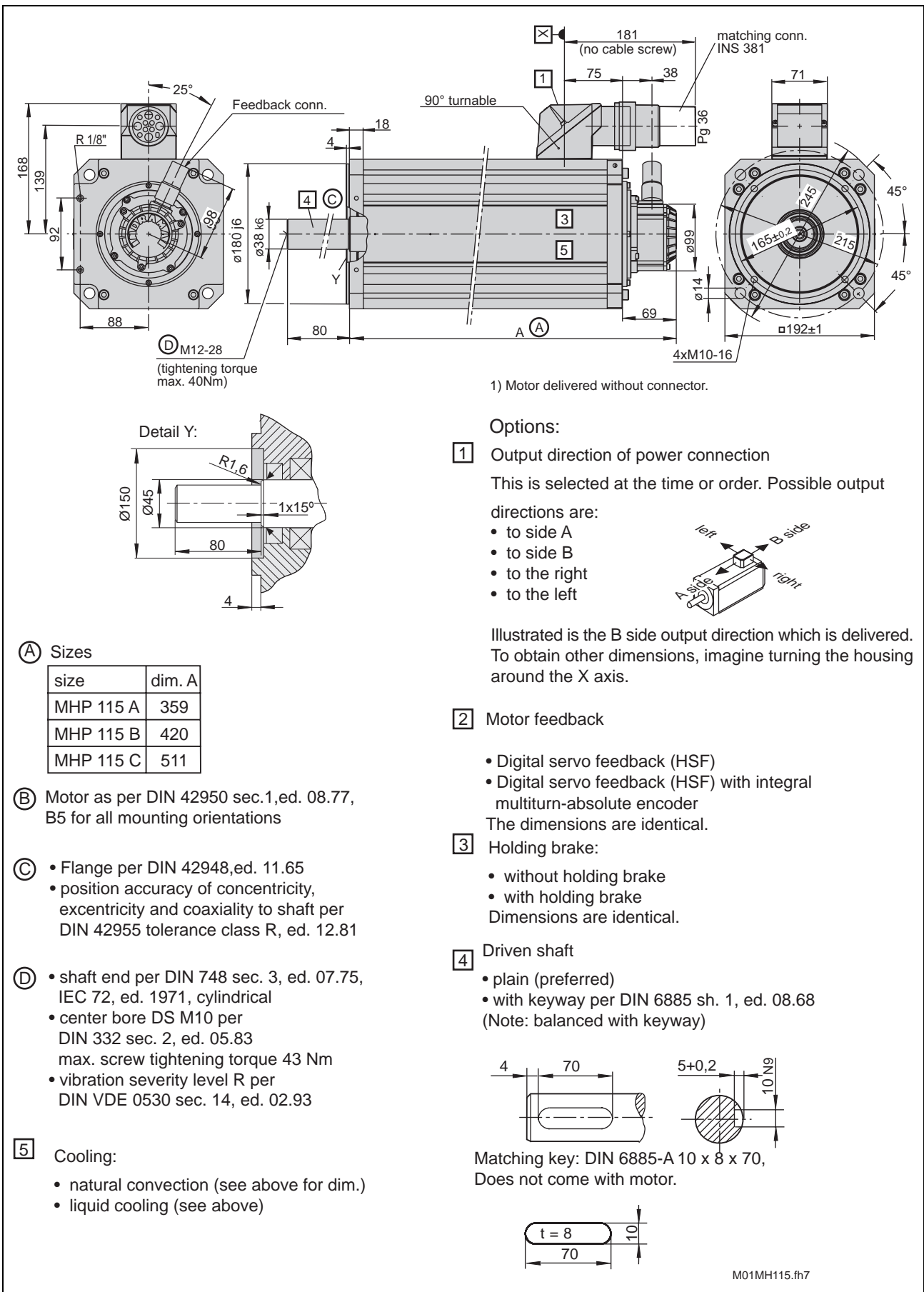

Fig. 13-15: Size sheet MHP115.-...-...-F

13.7 Blower units

Selecting the blower unit

Use the table below to select the blower unit.

Motor type	Order designation of blower unit	
	AC 115V / 60Hz	AC 230V / 50Hz
MHP115A-...	---	---
MHP115B-...	LEM-RB112C2XX	LEM-RB112C1XX
MHP115C-...	LEM-RB112C2XX	LEM-RB112C1XX
--- blower cannot be mounted!		

Fig. 13-17: Blower units MHP115

Motor with mounted blower unit

To obtain a motor with mounted surface cooling, list the type designation of the radial blower unit as a subitem of the MHP motor noting the desired arrangement of the blower.

Order position	Designation
1	1 St. digital AC motor MHP115B-024-NG0-BN
1.1	1 St. Blower unit LEM -RB112C1XX mounted to pos. 1 blower on left

Fig. 13-18: Order data for MHP motor with mounted blower unit

Motor with separate blower unit

If the blower is listed as a separate item, then it will be desired as such, i.e., not mounted.

Order position	Designation
1	1 St. digital AC motor MHP115B-024-NG0-BN
2	1 St. blower unit LEM -RB112C1XX

Fig. 13-19: Order data for MHP motor with separate blower unit

14 Condition at Delivery

14.1 General Information

Motors and accessories, such as cables, are packed in cartons at delivery. Depending on the number and/or size of these cartons, they are sometimes further placed on a pallet and lashed into place with metal bands. To protect against adverse weather, a carton is additionally pulled over the pallet and also lashed into place with metal bands.

14.2 Releasing the Metal Bands



Uncontrolled lashing out of metal bands upon removal!

Mechanical injuries are possible.

⇒ Release the metal bands very carefully !

⇒ Maintain sufficient distance !

14.3 Shipping Papers

A single delivery slip folded into an envelope accompanies the entire shipment. The merchandise is listed here by name and order number. If the listed contents are distributed over several packets (transport containers), then this is noted in the papers or on the freight sheets.

On the packaging of each motor, the following information is listed:

- type designation of motor
- customer
- delivery slip number
- consignment
- freight company making the delivery

(Also see section „15 Identifying the Merchandise“).

15 Identifying the Merchandise

15.1 Delivery slip

A delivery slip in an envelope accompanies the delivery. This slip lists the merchandise by name and order number. If the listed contents are distributed over multiple packages (transport containers), then such will be noted on the slip or freight papers.

15.2 Barcode Sticker

There is a barcode sticker on the packaging of every motor that specifies the following:

- type designation of motor
- customer
- delivery slip number
- consignment
- freight company

The barcode sticker helps identify the contents at the time the order is put together.



Abb. 15-1: Barcode sticker (example)

15.3 Type Plate

Motors There is a type plate on the motor at delivery. It is mounted to the motor housing. There is a second type plate affixed to the motor housing with tape. This can be placed on the machine in a visible spot in the event tht the original type plate on the motor is somehow hidden by the contours of the machine.

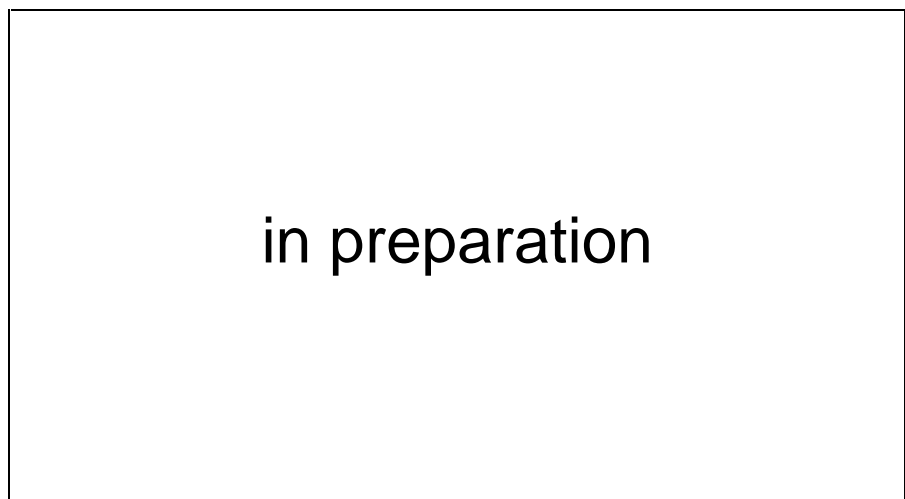
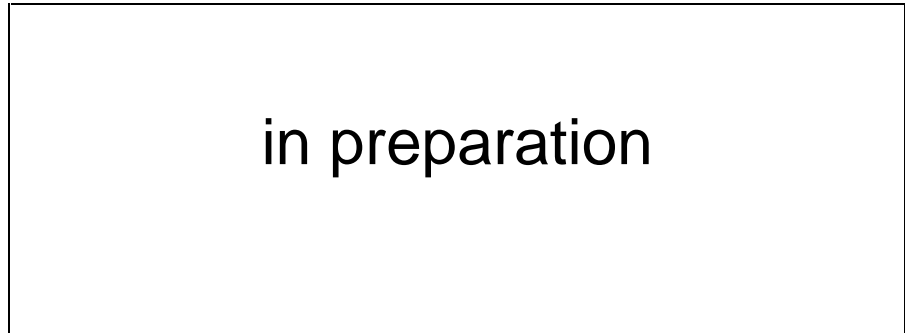

Fig. 15-2: Type plate (Example)

The type plates help to

- identify the motor
- replace parts in the event of a problem
- with service information

Blower units There is a type plate on the blower unit at delivery. It is mounted to the blower unit housing and protective by a foil. On it are printed type designation, serial number and data about the electrical connections.

Non-standard cables Order number printed on cable sheath.

Single plug-in connectors Type designations on plastic bag.

Standard cables Label (at cable end) with type designation.

16 Storage, Transport and Handling

16.1 Notes on Packaging

There are notes on storage, transport and handling on the packaging. Please pay attention to these.

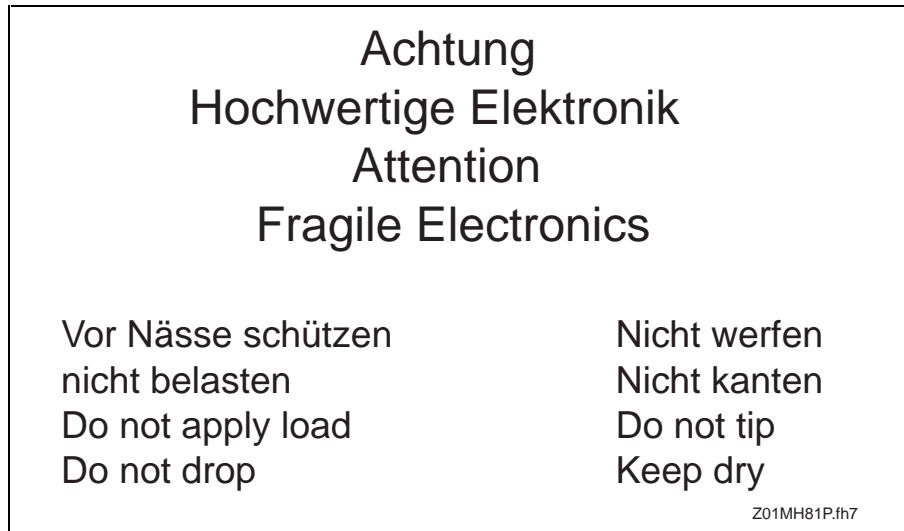

Fig. 16-1: Notes on storage, transport and handling on packaging

16.2 Storage

Note: Motor damage and loss of guarantee possible !

- Improper storage can damage the motor. Doing so means forfeiture of guarantee as well. Therefore, please pay attention to the following instructions.

Maintain the following conditions during storage:

- ⇒ Allowed temperature range: -20° C to +80° C.
- ⇒ Store motors dry, dust free and vibration free.
- ⇒ Store motors in a horizontal position.
- ⇒ Do not remove plastic protective sleeves on connectors and drive shaft. These protect against moisture and mechanical damage.
- ⇒ If liquid cooled motors were in use, then remove coolant from motor. Otherwise, freezing could damage the coolant channels.

16.3 Transport and Handling

Note: Motor damage and loss of guarantee possible !

- Improper transport and handling can damage the motor. Doing so also means forfeiture of the guarantee! Therefore, please note the following instructions.

Maintain the following conditions during transport and when handling:

- ⇒ Use appropriate transport vehicles/devices. Allow for weight of components (weight listed in the technical data of the motors or on the type plate of the motor).
- ⇒ Use shock-dampening if excess shocks could occur during transport. Note the limit data specified in section Identifying the Merchandise „Identifying the Merchandise“.
- ⇒ Transport in horizontal position only.
- ⇒ Do not pick up motor at surface cooler.
- ⇒ Use cranes with appropriate accessories to lift motor.
- ⇒ M8 ring screws (DIN580) can be inserted into the tapped holes of MHD115 motors on the motor housing and used when lifting the machine with chain tackle.
- ⇒ Do not damage motor flange or drive shaft!
- ⇒ Avoid impacts to the shaft.
- ⇒ Do not remove plastic sleeves on connectors and shaft until just before the motor is mounted.

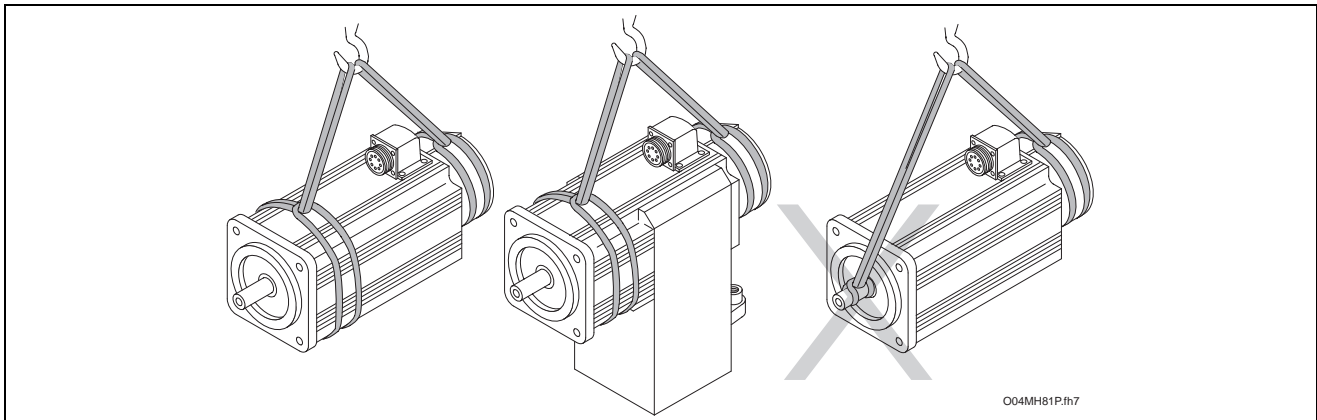

Fig. 16-2: Lifting and transporting with loop belts

17 Mounting and Installation

17.1 General Information on Mounting

- ⇒ Note all warning and safety guidelines listed in section Identifying the Merchandise „Identifying the Merchandise“. This helps minimize the risk of accident and avoids damage to the installation or motor.
- ⇒ Perform all necessary tasks with the utmost care. This will ensure that assembly and removal of all components is trouble free.

17.2 Mounting Motor

- ⇒ Obtain all needed tools, aids, measuring and testing equipment.
- ⇒ Check that all parts are clean.
- ⇒ Check whether parts are visibly damaged. Do not mount damaged parts.
- ⇒ Make sure that the mounting and assembly work takes place in a clean and dust free environment.
- ⇒ Make sure that the location notch for the motor flange is burr free.
- ⇒ Mount the motor. All dimensions and tolerances on the installation must be maintained. Relevant data is listed in the section "MHP ..." under the "Dimensional data" section.
- ⇒ If the motor is liquid cooled, then establish this connection and check that the coolant line can stand up to 5 bar. Also make sure that the required amount of coolant is flowing through the motor.

17.3 Connecting the Motor

After the motor is mounted, make all the necessary connections.



DANGER

Danger to life due to electrical voltage !

Working in the area of parts that are live is dangerous.

Therefore:

- ⇒ Only electrically trained personnel should conduct the work. Electrical tools have to be used.
 - ⇒ Before starting to work, shut the installation down and secure mains switch against an unintentional or unauthorized switching back on.
 - ⇒ Using suitable measuring devices check their is any residual voltage within the installation or parts, e.g., from capacitors. Wait until they have discharged.
-

**WARNING****Injury to personnel or property damage possible !**

Interrupting or connecting voltage-conductive lines can generate unforeseen dangerous situations or cause damage. Therefore:

- ⇒ insert or remove plugs only if they are dry, and non-conducting
- ⇒ When installation is in operation, then all plug-in connections must be firmly in place.

**WARNING****Danger of short circuit caused by coolants or lubricants !**

A short circuit in a live line can cause unforeseen dangerous situations or cause damage. Therefore:

- ⇒ Place protective caps over open power connections during installation or when replacing drive components. Especially if splashing from coolants or lubricants is possible.

The terminal diagrams from Rexroth Indramat only should be used when developing the terminal diagrams of the installation !

- ⇒ Connect the motor as specified in the diagram of the machine manufacturer! The diagram found in section 5.1 can be used if identifying the Merchandise is needed.

Connecting Standard Cables

Power cables

**Power cable connections for
MHP041
MHP071
and MHP090**

When connecting power connector INS0681 with threaded end, do as follows:

- ⇒ Place the power connector at the thread of the connector housing into its correct position.
- ⇒ Manually tighten the screwed cap of the power connector. By following-up with the cable it is possible to gradually bring the power connector into its final position.
- ⇒ Manually tighten the capped screw firmly.

**Power cable connections for
MHP093
MHP112
and MHP115**

When connecting power connectors INS0381 or INS0481 with bayonette cap, do as follows:

- ⇒ Place the power connector at the bayonette thread of the connector housing into its correct position.
- ⇒ Manually turn the capped screw of the power connector until it clicks into its end position (correct position visible by red dot over red triangle).

Feedback cable

**Connecting the feedback
connector**

When connecting the feedback connector do as follows:

- ⇒ Set the feedback connector at the thread of the connector housing into its correct position.
- ⇒ Manually tighten the capped screw of the feedback connector. By following-up with the cable the feedback connector can gradually be brought into its end position.
- ⇒ Manually tighten the capped screw firmly.

Changing the Output Direction of Power and Feedback Connections

Changing connector direction
with MHP041
MHP071
MHP090

Power connector

The output direction of the power connectors with motors MHP041, MHP071 and MHP090 can be changed during mounting. The flange socket have been constructed so that they can turn (angle 270°).

How to set the desired cable output directions is described below.

Note: Do not use any tools (e.g., pliers or screwdrivers) to turn the motor flange socket. This could easily be damaged.

It is easy to turn the flange socket once the right connector is in place. The leverage of the connector makes it possible to bring the flange socket into the desired position by hand.

Procedure:

⇒ Connect motor power cable to flange socket.

⇒ Move socket into position by turning the connector.

The output direction is set.

Note: Any changes in the flange socket decreases holding torque in the set position. To ensure that needed holding torque of the flange socket it is advisable to alter cable output direction no more than five times!

A "rebuilding" (removal/assembly of flange socket by 90°) of the flange socket is not needed. Doing so could cause the following problems:

- The sealing of the O-ring between flange socket and motor housing is endangered.
- It is possible that the prescribed torques may not be maintained.
- The TFL coating (securing of screw) of the mounting screws is worn down each time it is screwed out which means that it no longer serves its purpose.

Note: Forfeiture of guarantee !

- If the cable output direction is altered by "rebuilding", then Indramat's whole system guarantee is forfeited. The cable output direction may only be altered by turning the flange socket.
-

Changing output direction in
MHP093
MHP112
MHP115

If the cable output direction of the power connectors was not specified at the time MHP093, MHP112 or MHP115 motors were ordered and then the direction wanted is a different one, then it is possible to turn it by 90°.

Procedure:

⇒ Remove the two mounting screws 4 and then remove terminal box lid 2.

⇒ Remove the four mounting screws 3.

⇒ Turn the connector housing 1 in terms of the motor housing into the position wanted (in increments of 90°).

- ⇒ Make sure that the cable strands are not damaged or that there is no tension. Work through the opening that was created by the removal of lid 2.
- ⇒ Now, retighten the four mounting screws 3 (tightening torque 3.1 Nm \pm 10%).
- ⇒ Make sure that while retightening the screws no cable strands or sealing rings are damaged.
- ⇒ Re-mount lid 2 back onto housing 1 and re-tighten mounting screws 4 (tightening torque 3.1 Nm \pm 10%).

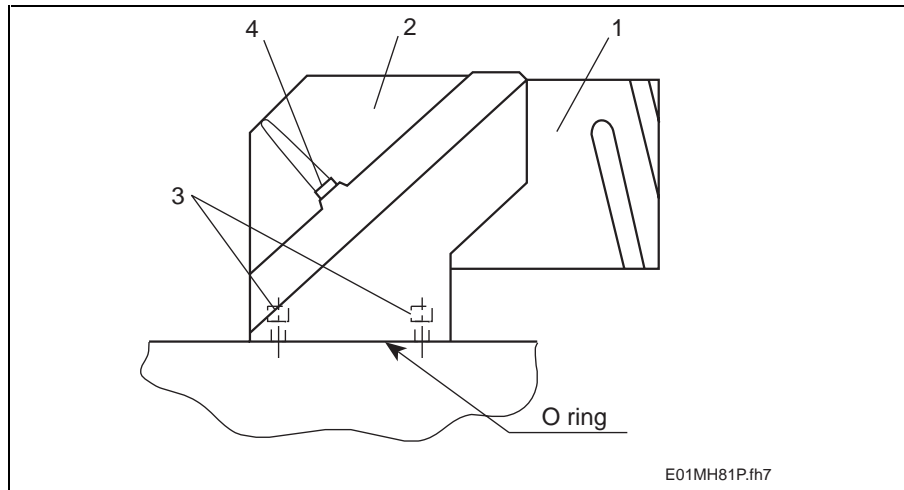

Fig. 17-1: Turning the power connectors

Note: The output direction of the connectors can be specified with an appropriate code at the time of order.

Feedback connector

Changing connector direction with
MHP041
MHP071
MHP090

The output direction can be selected at the time of mounting with motors MHP041, MHP071 and MHP090. The flange socket have been constructed so that they can be turned (turning range 270°)

How to set the wanted connector output direction is described below.

Note: Do not use any tools (e.g., pliers or screwdrivers) to turn the motor flange socket. This could easily be damaged.

It is easy to turn the flange socket once the right connector is in place. The leverage of the connector makes it possible to bring the flange socket into the desired position by hand.

Procedure:

- ⇒ Connect motor power cable to flange socket.
 - ⇒ Move socket into position by turning the connector.
- The output direction is set.

Note: Any changes in the flange socket decreases holding torque in the set position. To ensure that needed holding torque of the flange socket it is advisable to alter cable output direction no more than five times!

A "rebuilding" (removal/assembly of flange socket by 90°) of the flange socket is not needed. Doing so could cause the following problems:

- The sealing of the O-ring between flange socket and motor housing is endangered.
- It is possible that the prescribed torques may not be maintained.
- The TFL coating (securing of screw) of the mounting screws is worn down each time it is screwed out which means that it no longer serves its purpose.

Note: Forfeiture of guarantee !

- If the cable output direction is altered by "rebuidling", then Indramat's whole system guarantee is forfeited. The cable output direction may only be altered by turning the flange socket.

**Changing cable output directions in
MHP093
MHP112
MHP115**

If the cable output directions of the angle feedback connectors in MHP093, MHP112 and MHP115 motors is not the one wanted, then it can be turned in steps of 90°. To change, do as follows:

- ⇒ Release the four mounting screws on the top side of the connector.
- ⇒ Turn that part of the connector with the capped screw in contact to the connector housing into the position wanted (increments of 90°).
- ⇒ Re-tighten the mounting screws (tightening torque 0.8 Nm ±10%).
- ⇒ Make sure that no cable strands or sealing rings are damaged during the re-tightening.

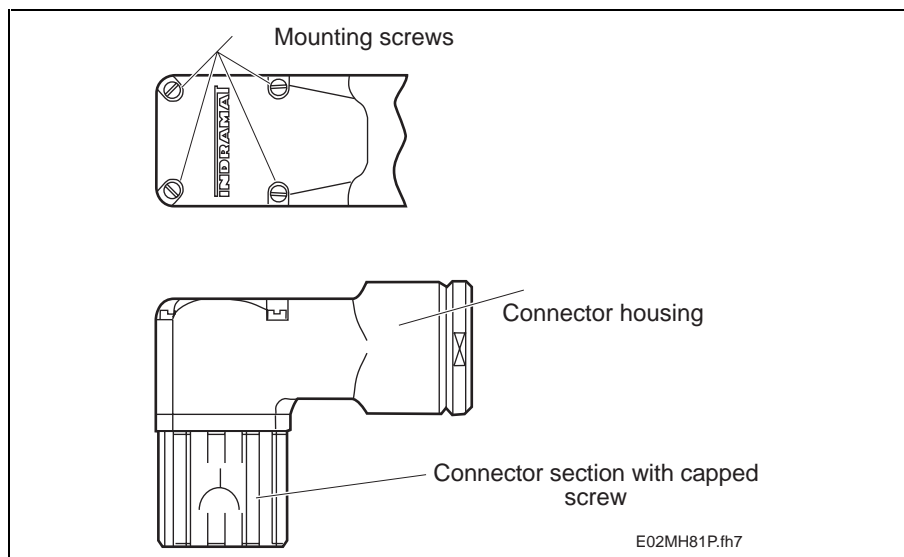

Fig. 17-2: Connector part designations with angle feedback connectors

Note: Applications with high vibration and shock loads require that the feedback connector be screws with a screw bonding agent.

17.4 Connecting and Mounting the Blower Connector

Electrical connections The connecting cable should be a three-strand type with a cross section of at least 0.75 mm^2 .

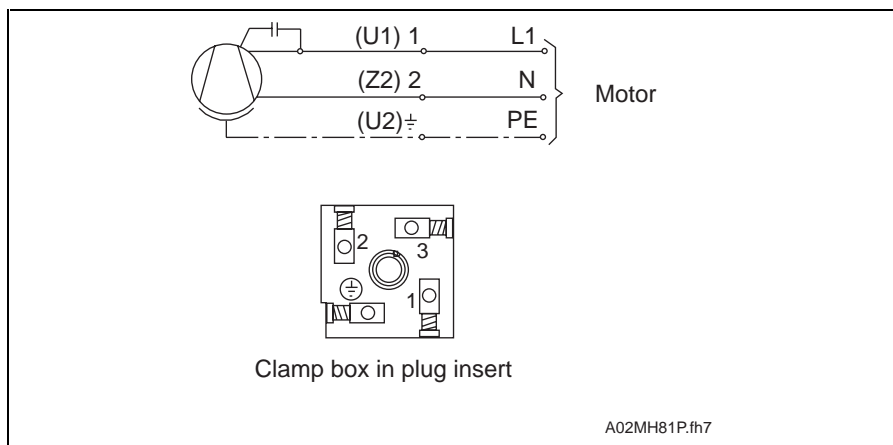

Fig. 17-3: Connecting diagram of blower

How to mount the connecting cable to the blower connector:

- ⇒ Release conduit thread 6 (SW 17).
- ⇒ Pull out cylindrical screw 1 using screwdriver 5 from socket 4.
- ⇒ Pull connector housing 2 with connector insert 3 out of socket 4.
- ⇒ Pull cylindrical screw 1 out.
- ⇒ Lift insert 3 out using screwdriver 5 (see Fig. 17-4) and pull it out of connector housing 2.
- ⇒ Place conduit thread 6, ring 7, seal 8 and connector housing 2 onto connecting cable ($3 \times 0.75 \text{ mm}^2$).
- ⇒ Strip outside cable sheath about 20 mm, litz wires 10 mm and connect as described above to connector insert 3.
- ⇒ Insert insert 3 into housing 2, put cylindrical screw 1 into place, screw connector onto socket 4.
- ⇒ Tighten conduit thread 6, make sure of sufficient strain relief.

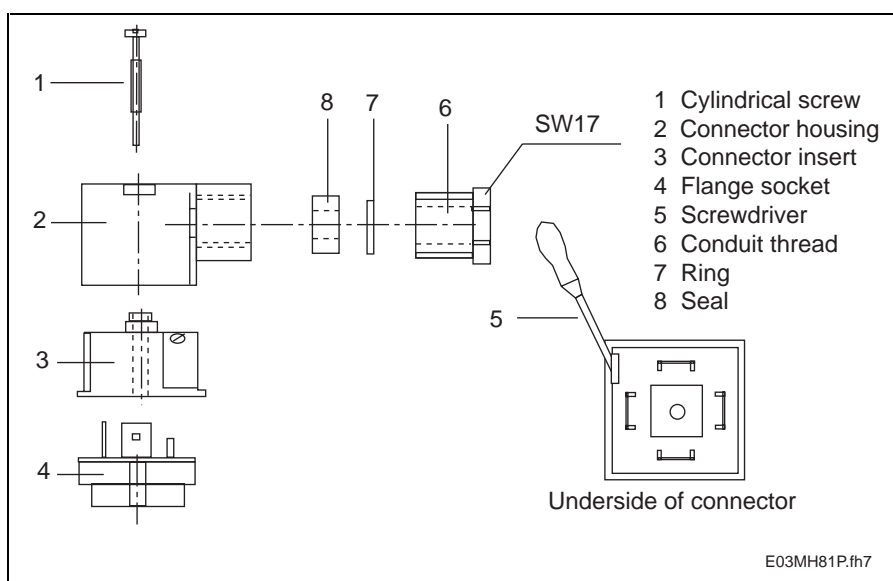

Fig. 17-4: Mounting the connecting cable to the blower connector

17.5 Re-seating the Holding Brake

Note: Holding brake could be worn down!

- The holding brake wears down after about 20,000 revolutions of the motor if it is closed. Therefore, please note the following!
-

To ensure a trouble-free functioning of the holding brake it is necessary to check the holding torque of the brake prior to installation.

If the holding torque specified in the data sheets is not reached, then it becomes necessary to re-seat the holding brake.

To re-seat the holding brake remove all existing connections between the motor and the drive controller (power and feedback connectors):

⇒ Make sure that the motor is not electrically connected to the drive controller.

⇒ Turn the motor shaft by hand in terms of the motor housing with the holding brake closed by about 50 rotations.

The holding brake is now ready to work.

18 Service Guidelines

18.1 Maintenance Work

The following should be performed regularly and no later than one year after initial commissioning.

- remove from motors all dust, chips or similar
- check the functioning of any motor blowers or surface coolers
- check air circulation of surface coolers
- check function of any liquid coolers (pressure of system, coolant level, flow through and so on).

18.2 Contacting Customer Service

To quickly and effectively solve problems, use our Service Hotline.

⇒ Before calling, please note:

- type data of the drive controllers and motors
- problem
- fault/diagnostic displays (if given).

The Service Hotline is available:

Monday - Friday	7 - 23 hours CET
Saturday	8 - 20 hours CET
Sundays and holidays	9 - 19 hours CET

at

0171 - 333 882 6 **or** 0172 - 660 040 6.

⇒ If motor have to be returned, please copy the fault report on the next page and fill it out completely and include it with the return.

⇒ If motors are liquid cooled, then remove the liquid prior to transport. There exists, otherwise, the danger o the coolant freezing and damaging the coolant channels.

⇒ Send all necessary reports and forms back with the machine to expedite any repairs.

This will help our Repair Service to quickly solve problems.

18.3 Fault Report

in
preparation

Fig. 18-1: Fault report

19 Index

A

Ambient Temperature 4-1
Ambient temperature and installation elevation 4-1

B

Barcode sticker 15-1
Bearing service life 4-10

C

Chemical features 5-11
Commutation 1-1, 1-2
Construction 1-2
Coolant 6-2
Coolant lines 6-1
Cooling mode 1-3
Cooling system components 6-1

D

driven shaft
 driven shaft with keyway 4-8
Driven shaft 1-3
 plain driven shaft 4-8
 shaft load 4-8
 Thermal changes in length 4-10
Dynamics 1-1

E

Electrical connection
 angle feedback connector 4-14
 Connection diagram of MHP motors 5-1
 Feedback cable 5-10
 Feedback connector 5-16
 Power cable 5-2

F

Feedback cable 5-10
Feedback connector 4-14, 5-16, 17-3

H

Holding brake 1-3, 4-11
Housing coat 4-6
Housing overtemperature 4-14

I

Improper Use 2-2
Installation Elevation 4-1

K

Knee speed 4-16

L

Load factor 4-1

M

Maintenance-free operation 1-1
Motor feedback 1-3
Motor overview for selecting motor power cables for an MHP 5-4
Motor overview when selecting motor power cables for an MHP 5-14
Mounting drive components 4-10
Mounting positions 4-6

O

Operating curve 4-16
Operating reliability 1-1
Outgoing direction 4-13
Overload capabilities 1-1

P

Parts 1-2
Power cable 5-2
Power connector 17-4
Power connectors 5-15
Power data 1-1
Pressure loss 6-2
Primary coat 4-6
Proper use 2-1
Protection category 4-2

R

Redundant bearings 4-10

S

Safety Instructions for Electric Servo Drives and Controls 3-1
sealing air connection 4-2
Service Hotline 18-1
Shaft load
 Allowed Axial force 4-9
 Allowed radial load 4-9
 maximum allowed radial force 4-9
 MHD041 7-5
 MHP071 8-6
 MHP090 9-5
 MHP093 10-12
 MHP095 11-10
 MHP112 12-14
 MHP115 13-10
Shock damped 4-6
Shock loads 4-7
Shock resistance 4-6
Shock-decoupled 4-6
Sinusoidal oscillations 4-7
Storage 5-11
Structural shape 4-6
Surface cooling 4-11

T

Terminal diagram 17-2
Type codes
 MHP041 7-7
 MHP071 8-8
 MHP090 9-7
 MHP093 10-15
 MHP095 11-13
 MHP112 12-17
 MHP115 13-13
Type plate 15-2

U

User Guidelines 2-1

V

Versions 1-3

Vibration demands 4-6

W

Windings overtemperature 4-14

20 Kundenbetreuungsstellen - Sales & Service Facilities

Deutschland – Germany

vom Ausland:

(x) nach Landeskennziffer weglassen!!

from abroad:

don't dial (x) after country code!

Vertriebsgebiet Mitte <input checked="" type="checkbox"/> SALES Germany Centre <input checked="" type="checkbox"/> Service Rexroth Indramat GmbH Bgm.-Dr.-Nebel-Str. 2 97816 Lohr am Main Telefon: +49 (0)9352/40-0 Telefax: +49 (0)9352/40-4885	Vertriebsgebiet Mitte <input checked="" type="checkbox"/> SALES Germany Centre <input type="checkbox"/> Service Mannesmann Rexroth AG Gesch.ber. Rexroth Indramat Lilistraße 14-18 63067 Offenbach Telefon: +49 (0) 69/82 00 90-0 Telefax: +49 (0) 69/82 00 90-80	Vertriebsgebiet Ost <input checked="" type="checkbox"/> SALES Germany East <input checked="" type="checkbox"/> Service Rexroth Indramat GmbH Beckerstraße 31 09120 Chemnitz Telefon: +49 (0)371/35 55-0 Telefax: +49 (0)371/35 55-333	Vertriebsgebiet Ost <input checked="" type="checkbox"/> SALES Germany East <input type="checkbox"/> Service Mannesmann Rexroth AG GB Rexroth Indramat GmbH Holzhäuser Str. 122 04299 Leipzig Telefon: +49 (0)341/86 77-0 Telefax: +49 (0)341/86 77-219
Vertriebsgebiet Süd <input checked="" type="checkbox"/> SALES Germany South <input type="checkbox"/> Service Rexroth Indramat GmbH Ridlerstraße 75 80339 München Telefon: +49 (0)89/540138-30 Telefax: +49 (0)89/540138-10 indramat.mue@t-online.de	Gebiet Südwest <input checked="" type="checkbox"/> SALES Germany South-West <input checked="" type="checkbox"/> Service Mannesmann Rexroth AG Vertrieb Deutschland – VD-BI Geschäftsbereich Rexroth Indramat Regionalzentrum Südwest Ringstrasse 70 / Postfach 1144 70736 Fellbach / 70701 Fellbach Tel.: +49 (0)711/57 61–100 Fax: +49 (0)711/57 61–125	Vertriebsgebiet Nord <input checked="" type="checkbox"/> SALES Germany North <input type="checkbox"/> Service Rexroth Indramat GmbH Kieler Straße 212 22525 Hamburg Telefon: +49 (0)40/85 31 57-0 Telefax: +49 (0)40/85 31 57-15	Vertriebsgebiet Nord <input checked="" type="checkbox"/> SALES Germany North <input type="checkbox"/> Service Mannesmann Rexroth AG Vertriebsniederlassung Region Nord Gesch.ber. Rexroth Indramat Walsroder Str. 93 30853 Langenhagen Telefon: +49 (0) 511/72 66 57-0 Telefax: +49 (0) 511/72 66 57-93
Vertriebsgebiet West <input checked="" type="checkbox"/> SALES Germany West <input checked="" type="checkbox"/> Service Mannesmann Rexroth AG Vertrieb Deutschland Regionalzentrum West Borsigstrasse 15 D - 40880 Ratingen Telefon: +49 (0)2102/409-0 Telefax: +49 (0)2102/409-406	SERVICE - Hotline - 7 Tage / 24h - HELP DESK MO – FR - von 7 – 17 Uhr Telefax +49 (0)9352/40-4941 Telefon +49 (0)9352/40- Bernard A. -4894 Kolb R. -4922 Roeper P. -4359 Scheiner W. -4921 HOTLINE (17 - 07 + SA / SO) Telefon: +49 (0)172/660 04 06 oder/or Telefon: +49 (0)171/333 88 26		ERSATZTEIL - Hotline ♦ nur an Werktagen - only on working days - ♦ von 15 -18 Uhr - from 15-18 o'clock - Tel. +49 (0) 93 52/40 42 22

Kundenbetreuungsstellen in Deutschland - Service agencies in Germany

Europa – Europe

vom Ausland: (x) nach Landeskennziffer weglassen,

0 nach Landeskennziffer mitwählen (Italien)!

from abroad: don't dial (x) after country code,

dial 0 after country code (Italy)!

<p>Austria <input checked="" type="checkbox"/> SALES <input type="checkbox"/> Service</p> <p>Mannesmann Rexroth Ges.m.b.H. Gesch.ber. Rexroth Indramat Hägelingasse 3 A - 1140 Wien Telefon: +43 (0)1/9852540-400 Telefax: +43 (0)1/9852540-93</p>	<p>Austria <input checked="" type="checkbox"/> SALES <input type="checkbox"/> Service</p> <p>Mannesmann Rexroth G.m.b.H. Gesch.ber. Rexroth Indramat Industriepark 18 A - 4061 Pasching Telefon: +43 (0)7221/605-0 Telefax: +43 (0)7221/605-21</p>	<p>Belgium <input checked="" type="checkbox"/> SALES <input checked="" type="checkbox"/> Service</p> <p>Mannesmann Rexroth N.V.-S.A. Gesch.ber. Rexroth Indramat Industrielaan 8 B-1740 Ternat Telefon: +32 (0)2/5830719 Telefax: +32 (0)2/5830731 E-mail: indramat@rexroth.be</p>	<p>Denmark <input checked="" type="checkbox"/> SALES <input checked="" type="checkbox"/> Service</p> <p>BEC AS Zinkvej 6 DK-8900 Randers Telefon: +45 (0)87/11 90 60 Telefax: +45 (0)87/11 90 61</p>
<p>Chechia <input checked="" type="checkbox"/> SALES <input type="checkbox"/> Service</p> <p>Mannesmann-Rexroth, spol.s.r.o. Hviezdoslavova 5 CS - 627 00 Brno Telefon: +420 (0)5/48 126 358 Telefax: +420 (0)5/48 126 112</p>	<p>England <input checked="" type="checkbox"/> SALES <input checked="" type="checkbox"/> Service</p> <p>Mannesmann Rexroth Ltd. Rexroth Indramat Division Broadway Lane, South Cerney GB - Cirencester, Glos GL7 5UH Telefon: +44 (0)1285/863000 Telefax: +44 (0)1285/863030 sales@indramat.co.uk service@indramat.co.uk</p>	<p>Finland <input checked="" type="checkbox"/> SALES <input type="checkbox"/> Service</p> <p>Rexroth Mecman Oy Rexroth Indramat division Ansatie 6 SF-017 40 Vantaa Telefon: +358 (0)9/84 91-11 Telefax: +358 (0)9/84 91-13 60</p>	<p>France <input checked="" type="checkbox"/> SALES <input checked="" type="checkbox"/> Service</p> <p>Mannesmann Rexroth S.A. Division Rexroth Indramat Parc des Barbanniers 4, Place du Village F-92632 Gennevilliers Cedex Telefon: +33 (0)141 47 54 30 Telefax: +33 (0)147 94 69 41 Hotline: +33 (0)6 08 33 43 28</p>
<p>France <input checked="" type="checkbox"/> SALES <input type="checkbox"/> Service</p> <p>Mannesmann Rexroth S.A. Division Rexroth Indramat 270, Avenue de Lardenne F - 31100 Toulouse Telefon: +33 (0)5 61 49 95 19 Telefax: +33 (0)5 61 31 00 41</p>	<p>France <input checked="" type="checkbox"/> SALES <input type="checkbox"/> Service</p> <p>Mannesmann Rexroth S.A. Division Rexroth Indramat 91, Bd. Irène Joliot-Curie F - 69634 Vénissieux – Cedex Telefon: +33 (0)4 78 78 53 65 Telefax: +33 (0)4 78 78 53 62</p>	<p>Hungary <input checked="" type="checkbox"/> SALES <input type="checkbox"/> Service</p> <p>Mannesmann Rexroth Kft. Angol utca 34 H - 1149 Budapest Telefon: +36 (1) 364 00 02 Telefax: +36 (1) 383 19 80</p>	<p>Italy <input checked="" type="checkbox"/> SALES <input checked="" type="checkbox"/> Service</p> <p>Mannesmann Rexroth S.p.A. Divisione Rexroth Indramat Via G. Di Vittoria, 1 I - 20063 Cernusco S/N.MI Telefon: +39 02/92 36 52 70 Telefax: +39 02/92 36 55 12</p>
<p>Italy <input checked="" type="checkbox"/> SALES <input checked="" type="checkbox"/> Service</p> <p>Mannesmann Rexroth S.p.A. Divisione Rexroth Indramat Via Borgomanero, 11 I - 10145 Torino Telefon: +39 011/7 50 38 11 Telefax: +39 011/7 71 01 90</p>	<p>Italy <input checked="" type="checkbox"/> SALES <input type="checkbox"/> Service</p> <p>Mannesmann Rexroth S.p.A. Divisione Rexroth Indramat Via del Progresso, 16 (Zona Ind.) I - 35020 Padova Telefon: +39 049/8 70 13 70 Telefax: +39 049/8 70 13 77</p>	<p>Italy <input type="checkbox"/> SALES <input checked="" type="checkbox"/> Service</p> <p>Mannesmann Rexroth S.p.A. Divisione Rexroth Indramat Via Mascia, 1 I - 80053 Castellammare di Stabia NA Telefon: +39 081/8 71 57 00 Telefax: +39 081/8 71 68 85</p>	<p>Italy <input checked="" type="checkbox"/> SALES <input type="checkbox"/> Service</p> <p>Mannesmann Rexroth S.p.A. Divisione Rexroth Indramat Viale Oriani, 38/A I - 40137 Bologna Telefon: +39 051/34 14 14 Telefax: +39 051/34 14 22</p>
<p>Netherlands <input checked="" type="checkbox"/> SALES <input type="checkbox"/> Service</p> <p>Hydraudyne Hydrauliek B.V. Kruisbroeksestraat 1 (P.O. Box 32) NL - 5281 RV Boxtel Telefon: +31 (0)411/65 19 51 Telefax: +31 (0)411/65 14 83 e-mail: indramat@hydraudyne.nl</p>	<p>Netherlands <input type="checkbox"/> SALES <input checked="" type="checkbox"/> Service</p> <p>Hydrocare B.V. Kruisbroeksestraat 1 (P.O. Box 32) NL - 5281 RV Boxtel Telefon: +31 (0)411/65 19 51 Telefax: +31 (0)411/67 78 14</p>	<p>Norway <input checked="" type="checkbox"/> SALES <input type="checkbox"/> Service</p> <p>Rexroth Mecman AS Rexroth Indramat Division Berghagan 1 or: Box 3007 N -1405 Ski-Langhus N -1402 Ski Telefon: +47 (0)64 86 41 00 Telefax: +47 (0)64 86 90 62 jul.ruud@rexroth.no</p>	<p>Poland <input checked="" type="checkbox"/> SALES <input type="checkbox"/> Service</p> <p>Mannesmann Rexroth Sp.zo.o. Biuro Poznan ul. Dabrowskiego 81/85 PL - 60-529 Poznan Telefon: +48 061/847 67 99 Telefax: +48 061/847 64 02</p>
<p>Rumania <input checked="" type="checkbox"/> SALES <input type="checkbox"/> Service</p> <p>Mannesmann Rexroth Sp.zo.o. Str. Drobety nr. 4-10, app. 14 RO - 70258 Bucuresti, Sector 2 Telefon: +40 (0)1/210 48 25 +40 (0)1/210 29 50 Telefax: +40 (0)1/210 29 52</p>	<p>Russia <input type="checkbox"/> SALES <input checked="" type="checkbox"/> Service</p> <p>Tschudnenko E.B. Arsenia 22 RUS - 153000 Ivanovo Rußland Telefon: +7 093/223 96 33 oder/or +7 093/223 95 48 Telefax: +7 093/223 46 01</p>	<p>Spain <input checked="" type="checkbox"/> SALES <input checked="" type="checkbox"/> Service</p> <p>Mannesmann Rexroth S.A. Division Rexroth Indramat Centro Industrial Santiga Oradros s/n E-08130 Santa Perpetua de Mogoda Barcelona Telefon: +34 937 47 94 00 Telefax: +34 937 47 94 01 ricardo.panicello@rexroth-es.com</p>	<p>Spain <input checked="" type="checkbox"/> SALES <input checked="" type="checkbox"/> Service</p> <p>Goimendi S.A. Division Rexroth Indramat Jolastokieta (Herrera) Apartado 11 37 E - 20017 San Sebastian Telefon: +34 9 43/40 01 63 Telefax: +34 9 43/39 17 99</p>
<p>Sweden <input checked="" type="checkbox"/> SALES <input checked="" type="checkbox"/> Service</p> <p>Rexroth Mecman Svenska AB Rexroth Indramat Division Varuvägen 7 S - 125 81 Stockholm Telefon: +46 (0)8/727 92 00 Telefax: +46 (0)8/647 32 77</p>	<p>Slowenia <input checked="" type="checkbox"/> SALES <input checked="" type="checkbox"/> Service</p> <p>Rexroth Indramat elektromotorji d.o.o. Otoki 21 SLO - 64 228 Zelezniki Telefon: +386 64/61 73 32 Telefax: +386 64/64 71 50</p>	<p>Switzerland -East- <input checked="" type="checkbox"/> SALES <input checked="" type="checkbox"/> Service</p> <p>Mannesmann Rexroth Schweiz AG Gesch.ber. Rexroth Indramat Gewerbstraße 3 CH - 8500 Frauenfeld Telefon: +41 (0)52/720 21 00 Telefax: +41 (0)52/720 21 11</p>	<p>Switzerland -West- <input checked="" type="checkbox"/> SALES <input type="checkbox"/> Service</p> <p>Mannesmann Rexroth Suisse SA Département Rexroth Indramat Rue du village 1 CH - 1020 Renens Telefon: +41 (0)21/632 84 20 Telefax: +41 (0)21/632 84 21</p>
<p>Turkey <input checked="" type="checkbox"/> SALES <input checked="" type="checkbox"/> Service</p> <p>Mannesmann Rexroth Hidropar A..S. Fevzi Cakmak Cad No. 3 TR - 34630 Sefaköy Istanbul Telefon: +90 212/541 60 70 Telefax: +90 212/599 34 07</p>	<p>rexroth@cea.ru</p>		

Europäische Kundenbetreuungsstellen (ohne Deutschland)

European Service agencies (without Germany)

Außerhalb Europa - outside Europe

vom Ausland:

(x) nach Landeskennziffer weglassen!

from abroad:

don't dial (x) after country code!

<p>Argentina <input checked="" type="checkbox"/> SALES <input type="checkbox"/> Service</p> <p>Mannesmann Rexroth S.A.I.C. Division Rexroth Indramat Acassusso 48 41/7 RA - 1605 Munro (Buenos Aires)</p> <p>Telefon: +54 (0)11/4756 01 40 Telefax: +54 (0)11/4762 6862 e-mail:mannesmann@impsat1.com.ar</p>	<p>Argentina <input checked="" type="checkbox"/> SALES <input checked="" type="checkbox"/> Service</p> <p>NAKASE Servicio Tecnico CNC Calle 49, No. 5764/66 RA - 1653 Villa Balester Prov. - Buenos Aires</p> <p>Telefon: +54 (0) 11/4768 36 43 Telefax: +54 (0) 11/4768 24 13 e-mail: nakase@usa.net nakase@infovia.com.ar</p>	<p>Australia <input checked="" type="checkbox"/> SALES <input checked="" type="checkbox"/> Service</p> <p>AIMS - Australian Industrial Machinery Services Pty. Ltd. Unit 3/45 Horne ST Campbellfield , VIC 3061 AUS - Melbourne</p> <p>Telefon: +61 (0)3/93 59 02 28 Telefax: +61 (0)3/93 59 02 86</p>	<p>Australia <input checked="" type="checkbox"/> SALES <input type="checkbox"/> Service</p> <p>Mannesmann Rexroth Pty. Ltd. No. 7, Endeavour Way Braeside Victoria, 31 95 AUS - Melbourne</p> <p>Telefon: +61 (0)3/95 80 39 33 Telefax: +61 (0)3/95 80 17 33 Email: mel@rexroth.com.au</p>
<p>Brazil <input checked="" type="checkbox"/> SALES <input checked="" type="checkbox"/> Service</p> <p>Mannesmann Rexroth Automação Ltda. Divisão Rexroth Indramat Rua Georg Rexroth, 609 Vila Padre Anchieta BR - 09951-270 Diadema-SP [Caixa Postal 377] [BR-09901-970 Diadema-SP]</p> <p>Telefon: +55 (0)11/745 90 60 +55 (0)11/745 90 70 Telefax: +55 (0)11/745 90 50 e-mail: awittwer@rexroth.com.br</p>	<p>Brazil <input type="checkbox"/> SALES <input checked="" type="checkbox"/> Service</p> <p>Mannesmann Rexroth Automação Ltda. Divisão Rexroth Indramat R. Dr.Humberto Pinheiro Vieira, 100 Distrito Industrial BR - 89220-390 Joinville - SC [Caixa Postal 1273]</p> <p>Tel./Fax: +55 (0)47/473 58 33 Mobil: +55 (0)47 974 66 45 e-mail: prochnow@zaz.com.br</p>	<p>Canada <input checked="" type="checkbox"/> SALES <input checked="" type="checkbox"/> Service</p> <p>Basic Technologies Corporation Burlington Division 3426 Mainway Drive Burlington, Ontario Canada L7M 1A8</p> <p>Telefon: +1 905/335 55 11 Telefax: +1 905/335-41 84</p>	<p>China <input checked="" type="checkbox"/> SALES <input checked="" type="checkbox"/> Service</p> <p>Rexroth International Trade (Shanghai) Co., Ltd. Wai Gaoqiao Free Trade Zone No.122, Fu Te Dong Yi Road Shanghai 200131 - P.R.China</p> <p>Telefon: +86 21/58 66 30 30 Telefax: +86 21/58 66 55 23</p>
<p>China <input checked="" type="checkbox"/> SALES <input type="checkbox"/> Service</p> <p>Mannesmann Rexroth (China) Ltd. 15/F China World Trade Center 1, Jianguomenwai Avenue Beijing 100004, P.R.China</p> <p>Telefon: +86 10/65 05 03 80 Telefax: +86 10/65 05 03 79</p>	<p>China <input checked="" type="checkbox"/> SALES <input type="checkbox"/> Service</p> <p>Mannesmann Rexroth (China) Ltd. A-5F., 123 Lian Shan Street Sha He Kou District Dalian 116 023, P.R.China</p> <p>Telefon: +86 411/46 78 930 Telefax: +86 411/46 78 932</p>	<p>China <input checked="" type="checkbox"/> SALES <input type="checkbox"/> Service</p> <p>Mannesmann Rexroth (China) Ltd. Guangzhou Repres. Office Room 1014-1016, Metro Plaza, Tian He District, 183 Tian He Bei Rd Guangzhou 510075, P.R.China</p> <p>Telefon: +86 20/8755-0030 +86 20/8755-0011 Telefax: +86 20/8755-2387</p>	<p>Hongkong <input checked="" type="checkbox"/> SALES <input checked="" type="checkbox"/> Service</p> <p>Rexroth (China) Ltd. 1/F., 19 Cheung Shun Street Cheung Sha Wan, Kowloon, Hongkong</p> <p>Telefon: +852 22 62 51 00 Telefax: +852 27 44 02 78</p>
<p>India <input checked="" type="checkbox"/> SALES <input checked="" type="checkbox"/> Service</p> <p>Mannesmann Rexroth (India) Ltd. Rexroth Indramat Division Plot. 96, Phase III Peenya Industrial Area IND - Bangalore - 560058</p> <p>Telefon: +91 (0)80/8 39 73 74 Telefax: +91 (0)80/8 39 43 45</p>	<p>India <input checked="" type="checkbox"/> SALES <input checked="" type="checkbox"/> Service</p> <p>Mannesmann Rexroth (India) Ltd. Rexroth Indramat Division Plot. A-58, TTC Industrial Area Thane Turbhe Midc Road Mahape Village IND - Navi Mumbai - 400 701</p> <p>Telefon: +91 (0)22/7 61 46 22 Telefax: +91 (0)22/7 68 15 31</p>	<p>Indonesia <input checked="" type="checkbox"/> SALES <input type="checkbox"/> Service</p> <p>PT. Rexroth Wijayakusuma Jl. Raya Bekasi Km 21 Pulogadung RI - Jakarta Timur 13920</p> <p>Telefon: +62 21/4 61 04 87 +62 21/4 61 04 88 Telefax: +62 21/4 60 01 52</p>	<p>Japan <input type="checkbox"/> SALES <input checked="" type="checkbox"/> Service</p> <p>Rexroth Automation Co., Ltd. Service Center Japan Yutakagaoka 1810, Meito-ku, NAGOYA 465-0035, Japan</p> <p>Telefon: +81 (0)52/777 88 41 +81 (0)52/777 88 53 +81 (0)52/777 88 79 Telefax: +81 (0)52/777 89 01</p>
<p>Japan <input checked="" type="checkbox"/> SALES <input checked="" type="checkbox"/> Service</p> <p>Rexroth Automation Co., Ltd. Rexroth Indramat Division 1F, I.R. Building Nakamachidai 4-26-44, Tsuzuki-ku YOKOHAMA 224-0041, Japan</p> <p>Telefon: +81 (0)45/942 72 10 Telefax: +81 (0)45/942 03 41</p>	<p>Mexico <input checked="" type="checkbox"/> SALES <input type="checkbox"/> Service</p> <p>Mannesmann Rexroth Mexico S.A. de C.V. Calle Neptuno 72 Unidad Ind. Vallejo MEX - 07700 Mexico, D.F.</p> <p>Telefon: +52 5 754 17 11 +52 5 754 36 84 +52 5 754 12 60 Telefax: +52 5 754 50 73 +52 5 752 59 43 e-mail: gsonia@rexroth-mexico.com</p>	<p>Korea <input checked="" type="checkbox"/> SALES <input checked="" type="checkbox"/> Service</p> <p>Mannesmann Rexroth-Korea Ltd. Rexroth Indramat Division 1500-12 Dadae-Dong- Saha-Ku Pusan, 604-050 Republic of South Korea</p> <p>Telefon: +82 (0)51/2600 741 Telefax: +82 (0)51/2600 747</p>	<p>Korea <input checked="" type="checkbox"/> SALES <input checked="" type="checkbox"/> Service</p> <p>Seo Chang Corporation Ltd. Room 903, Jeail Building 44-35 Yeouido-Dong Yeoungdeungpo-Ku C.P.O.Box 97 56 ROK - Seoul</p> <p>Telefon: +82 (0)2/7 80 82 08 +82 (0)2/7 80 82 09 Telefax: +82 (0)2/7 84 54 08</p>
<p>Taiwan <input checked="" type="checkbox"/> SALES <input type="checkbox"/> Service</p> <p>Rexroth Uchida Co., Ltd. No.1, Tsu Chiang Street Tu Cheng Ind. Estate Taipei Hsien, Taiwan, R.O.C.</p> <p>Telefon: +886 2/2 68 13 47 Telefax: +886 2/2 68 53 88</p>		<p>South Africa <input checked="" type="checkbox"/> SALES <input checked="" type="checkbox"/> Service</p> <p>TECTRA Automation (Pty) Ltd. 28 Banfield Road, Industria North RSA - Maraisburg 1700</p> <p>Telefon: +27 (0)11/673 20 80 Telefax: +27 (0)11/673 72 69 georgv@hyauto.com</p>	

Kundenbetreuungsstellen außerhalb Europa - Service agencies outside Europe

Außerhalb Europa / USA - outside Europe / USA

USA <input checked="" type="checkbox"/> SALES <input checked="" type="checkbox"/> Service Mannesmann Rexroth Corporation Rexroth Indramat Division 5150 Prairie Stone Parkway USA -Hoffman Estates, IL 60192-3707 Telefon: +1 847/6 45 36 00 Telefax: +1 847/6 45 62 01 service@indramat.com	USA <input checked="" type="checkbox"/> SALES <input checked="" type="checkbox"/> Service Mannesmann Rexroth Corporation Rexroth Indramat Division Central Region Technical Center USA - Auburn Hills, MI 48326 Telefon: +1 248/3 93 33 30 Telefax: +1 248/3 93 29 06	USA <input checked="" type="checkbox"/> SALES <input checked="" type="checkbox"/> Service Mannesmann Rexroth Corporation Rexroth Indramat Division Southeastern Technical Center 3625 Swiftwater Park Drive USA - Suwanee Georgia 30174 Telefon: +1 770/9 32 32 00 +1 770/9 32 19 03	USA <input checked="" type="checkbox"/> SALES <input checked="" type="checkbox"/> Service Mannesmann Rexroth Corporation Rexroth Indramat Division Northeastern Technical Center 99 Rainbow Road USA - East Granby, Connecticut 06026 Telefon: +1 860/8 44 83 77 +1 860/8 44 85 95
USA <input checked="" type="checkbox"/> SALES <input checked="" type="checkbox"/> Service Mannesmann Rexroth Corporation Rexroth Indramat Division Charlotte Regional Sales Office 14001 South Lakes Drive USA - Charlotte, North Carolina 28273 Telefon: +1 704/5 83 97 62 +1 704/5 83 14 86			USA Service HOTLINE +1-800-860-1055 - 7 days / 24hrs -

Kundenbetreuungsstellen außerhalb Europa / USA

Service agencies outside Europe / USA

Bosch Rexroth AG
Electric Drives and Controls
P.O. Box 13 57
97803 Lohr, Germany
Bgm.-Dr.-Nebel-Str. 2
97816 Lohr, Germany
Phone +49 (0)93 52-40-50 60
Fax +49 (0)93 52-40-49 41
service.svc@boschrexroth.de
www.boschrexroth.com



R911283692